

INFRA-KIT

Heavy-duty shoring system

User guide



Contents

1	Product features	4
1.1	General information.....	4
1.2	Safety instructions	4
1.3	Conventions in this user guide.....	6
1.4	Other relevant documents.....	7
2	Overview	8
2.1	INFRA-KIT H.....	8
2.2	INFRA-KIT L and M.....	9
3	Components	10
3.1	INFRA-KIT H.....	10
3.2	Accessories INFRA- KIT H	12
3.3	INFRA-KIT L and M.....	15
3.4	Accessories INFRA-KIT L and M	21
4	Component dimensions	25
4.1	INFRA-KIT H.....	25
4.2	INFRA-KIT M	26
4.3	INFRA-KIT L.....	27
5	Connecting Beams INFRA-KIT H	29
6	General Information on IK Walers L and M	30
6.1	Orientation of Walers	30
7	Structural information	32
7.1	Walers L	32
7.2	Walers M.....	34
7.3	IK Waler Connector L (code:608420).....	35
7.4	IK Adapter Waler Connector L (code:608460).....	36
7.5	IK Waler Connector L 25 (code:608445).....	38
7.6	IK Waler Connector Flex L (code:608490).....	38
7.7	IK Cross Connector L (code:608450).....	39
7.8	IK Adapter L (code:608480).....	40
7.9	IK Waler Connector M (code:608430).....	41
7.10	IK Adapter Waler Connector M (code:608440)	42
7.11	IK Waler Connector Flex M (code:608485).....	42
7.12	IK Cross Connector M (code:608470).....	43
7.13	IK Adjustable Connector	44
7.14	IK Jack (code:608775)	45
7.15	IK Adapter M/L (code:608770)	45
7.16	IK Wheel Connector (code:608600).....	46
7.17	Information on using bolts of class 8.8	46
8	Connecting IK Walers L and M	46
8.1	Changing position of Waler Bolts	47
8.2	End-to-end connection of IK Walers	48
8.3	Perpendicular rigid connection of walers.....	60
8.4	Connecting Walers on top of one another.....	64
8.5	Articulated connection of walers	70
8.6	Articulated connection (using the waler's web).....	78

8.7	Articulated connection (outside the hole grid).....	81
9	Attaching jacks and bases	85
9.1	Attaching the IK Jack 180.....	85
9.2	Attaching the IK Wheel Connector L/M and Heavy-duty Castors.....	86
10	IK Spindles.....	89
10.1	Safe Working Loads	89
10.2	Possible connection points and extension lengths of IK Spindles	91
10.3	Connecting IK Spindles directly to IK Walers	92
10.4	Connecting IK Spindles to other components	93
11	Bracing.....	95
11.1	Attaching the IK Scaffold Tube Adapter.....	95
11.2	Attaching the Half Coupler to flange bores (only IK Walers M)	96
11.3	Bracing IK Walers	97
12	Edge protection	98
12.1	Panels and posts	100
12.2	Constructing edge protection with PROTECTO Post 130 Adjustable.....	104
12.3	Constructing edge protection with MODEX	106
13	Assembly of INFRA-KIT H.....	108
13.1	Recommended sequence for horizontal assembly and transport.....	108
13.2	Recommended vertical assembly sequence on site.....	120
14	Preloading diagonal Tie Rods (INFRA-KIT H)	127
14.1	Countering Tie Rods at top	127
14.2	Preloading Tie Rods at base with Tension Nut Set DW 15.....	127
14.3	Imposing defined preload force with tie elongation	128
14.4	Imposing defined preload force with torque.....	129
14.5	Torque for bolts with metric thread.....	130
15	Attaching the Centring Bar	130
16	Additional example of use.....	131
17	Chronology.....	132

1 Product features

The HÜNNEBECK INFRA-KIT is a versatile modular system that can take heavy loads safely and economically. It is particularly well suited for the construction of bridges, open and mining tunnels, and other civil engineering projects. Supporting structures can be reliably planned and implemented to accommodate the required loads. Due to the standardised, logical components and connections, the INFRA-KIT system is particularly user friendly and cost-efficient. The INFRA-KIT is safe and easy to assemble.

The system is flexible enough to meet the needs of the specific project, drastically decreasing the effort needed to plan standard applications. This means that the time and expense required to produce special parts is reduced to a minimum.

The modular system is based on the proven Load-bearing Frame Props, each of which has a safe working load of up to 210.00 kN, and the Main Beams that cover a wide range of uses. These components form the INFRA-KIT H system. Due to the high load-bearing capacity of the components, even tall supporting structures and wide-span thoroughfares can be easily constructed in compliance with EU-wide safety standards.

The INFRA-KIT H system is supplemented by walers and spindles from the INFRA-KIT L and M system. They are used e.g. to form trusses and to bear light and

medium-sized loads imposed by various formwork or building geometries.

Practical and innovative details make it easy to work with this modular system. And additional components from the HÜNNEBECK product range can be added to the INFRA-KIT, ensuring efficient project planning, preparation and implementation. HÜNNEBECK's European rental park offers all of the components for rent.

1.1 General information

This user guide contains important information regarding the assembly and use of the HÜNNEBECK INFRA-KIT as well as safety procedures that are important for safe erection and use on site. This user guide is intended to serve as an aid to working effectively with the HÜNNEBECK INFRA-KIT. So please carefully read this user guide before erecting and using the HÜNNEBECK INFRA-KIT, keep it nearby and save it for future reference.

This user guide is designed for commercial users with proper professional training. The information and procedures described here comply with the laws and the occupational health and safety regulations of Germany and Austria. Hünnebeck assumes no liability in the event of deviations from the information and procedures described in the user guide or in the event that the equipment is used outside of this area.

1.2 Safety instructions

Notes on intended and safe use of formwork and falsework. The contractor is obligated to compile a risk assessment and assembly instructions.

The latter is not usually identical to the user guide.

- Risk assessment

The contractor is responsible for the preparation, documentation, implementation and revision of a risk assessment for each construction site. His/her employees are obliged to implement the resulting measures in accordance with all legal requirements.

- **Assembly instructions**
The contractor is responsible for compiling written assembly instructions. The user guide is a fundamental aspect of the assembly instructions.
- **User guide**
Formwork is a type of equipment intended only for commercial applications. The equipment may be used only by properly trained personnel under the authority of qualified supervisors.
The user guide is an integral component of the formwork construction. At a minimum, it contains safety notes, information on the standard configuration, the intended use and a description of the system. The functional instructions (standard configuration) contained in the user guide are to be complied with as stated. Enhancements, deviations or changes represent a potential risk and therefore require separate verification (with the help of a risk assessment) or a set of assembly instructions which comply with the relevant laws, standards and safety regulations.
The same applies in cases where formwork/falsework components are provided on site.
- **Accessibility of the user guide**
The contractor has to ensure that site personnel are familiar with the user guide provided by the manufacturer or the formwork supplier and that it is readily accessible at all times.
- **Illustrations**
Some of the illustrations in the user guide show incomplete assembly and do not necessarily show all aspects relevant to safety.
Safety devices may not always appear in the illustrations, but they are nevertheless mandatory.
- **Material check**
Formwork and falsework material deliveries are to be checked on arrival at the construction site / destination as well as before each use to ensure that they are in perfect condition and function correctly. Modifications to the formwork materials are not permitted.
- **Spare parts and repairs**
Only original parts may be used as spare parts. Repairs may be performed only by the manufacturer or authorised facilities.
- **Use of other products**
Combining formwork components from different manufacturers poses certain risks. Examine such components individually for suitability; they may require a separate user guide.
- **Note on structural analysis**
The SWL values presented in this document are on the basis of a plastic approach.

1.3 Conventions in this user guide

1.3.1 Warnings and notes



DANGER

Danger!

Danger indicates a hazardous situation that, if not avoided, will cause death or serious injury.



WARNING

Warning!

Warning indicates a hazardous situation that, if not avoided, can cause death or serious injury.



CAUTION

Caution!

Caution indicates a hazardous situation that, if not avoided, can cause minor or moderate injury.

NOTE

Note!

Note indicates a hazard that can cause property damage.



This note indicates that an additional inspection is required.



This note shares practical experience with the user, e.g. how to perform a task more easily or quickly.



This note indicates particularly important information, e.g. that a requirement has to be fulfilled.



This symbol indicates that additional information from other documents is required. These documents could be user guides or operating instructions for other products.

1.3.2 Instructions

In this document instructions are always identified with the word **Step**, e.g.

Step 1 Insert the locking bolt into the hole from the outside.

Step 2 Secure the pin with the spring cotter pin.

Miscellaneous

We explicitly reserve the right to make changes resulting from technical improvements. For the safety-related application and use of the products, all current country-specific laws, standards as well as other safety regulations are to be complied with, without exception. They form a part of the obligations of employers and employees regarding industrial safety. This results in, among other things, the responsibility of the contractor to ensure the stability of the formwork and falsework constructions as well as the structure during all stages of construction.

This also includes the basic assembly, dismantling and transport of the formwork and falsework along with their components. Inspect the entire structure during and upon completion of assembly.

1.4 Other relevant documents

This user guide describes the safe use and operation of the MANTO system. Please also observe and comply with the information and instructions contained in the following documents pertaining to specific components:

User Guides

- PROTECTO edge protection user guide
- ST 60 Shoring Tower
- Load-bearing frame prop

All of these documents can be downloaded at <http://huennebeck.com/downloads>.

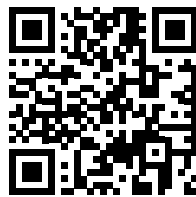

2 Overview

2.1 INFRA-KIT H

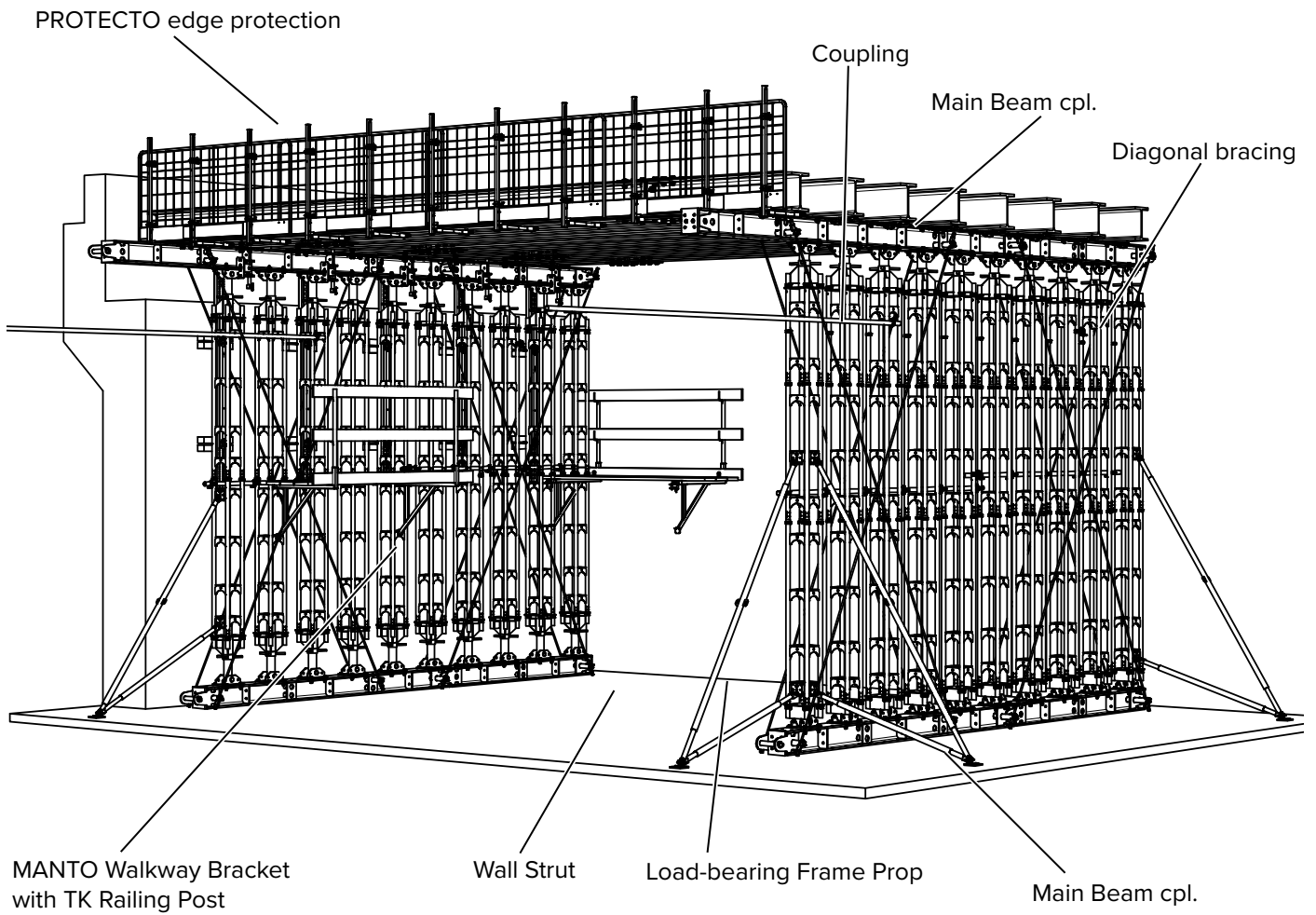

2.2 INFRA-KIT L and M

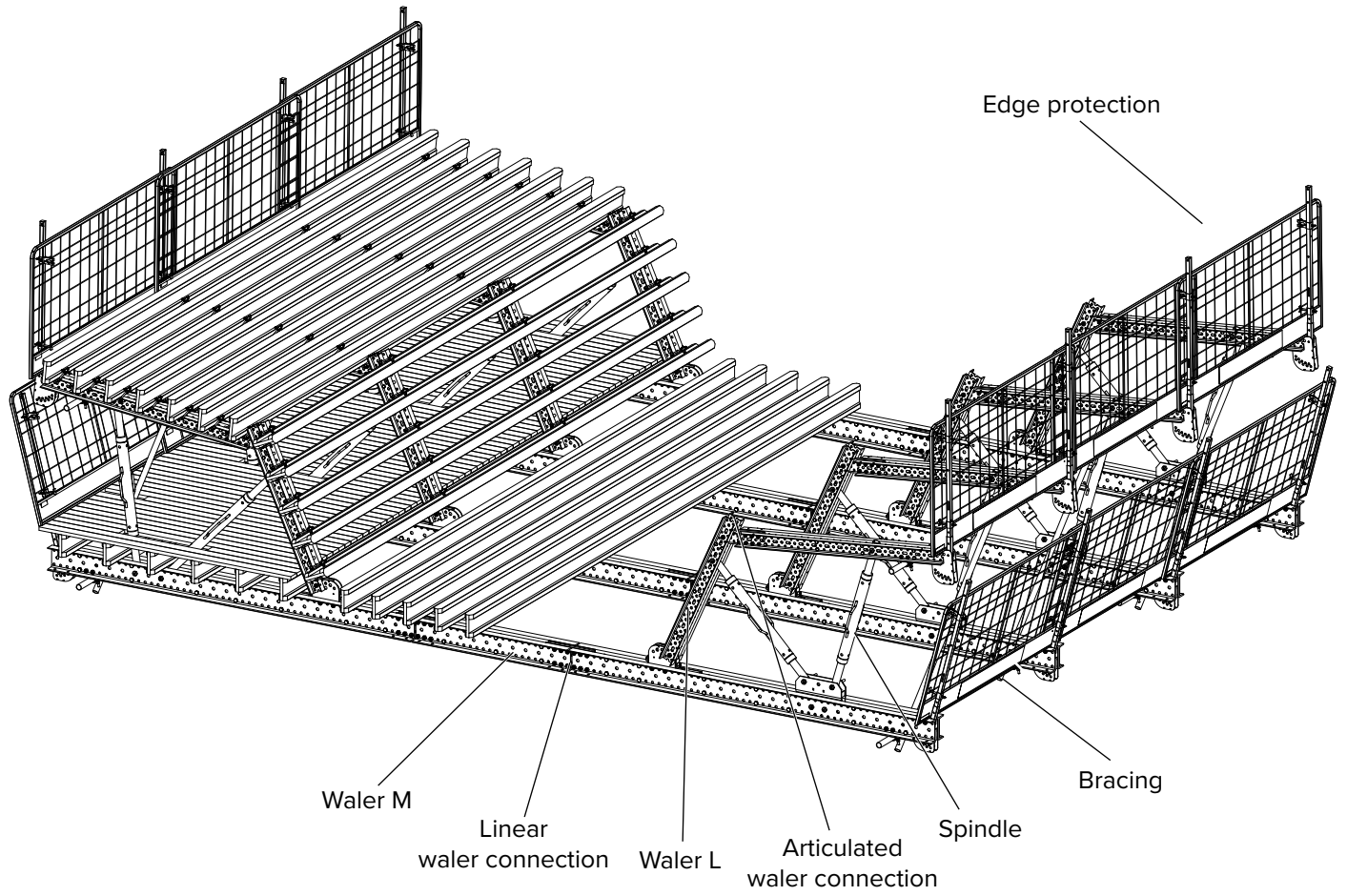

3 Components

Many different aspects of infrastructure construction can be handled with INFRA-KIT series. This is why the INFRA-KIT is available in three different sizes H, L and M. INFRA-KIT H is designed to transfer the heaviest loads, while INFRA-KIT L and M are intended to be used for lighter and medium-weight applications.

3.1 INFRA-KIT H

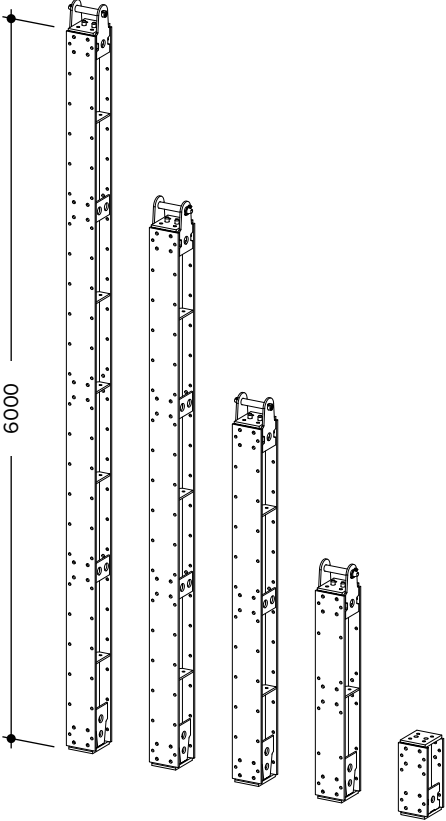
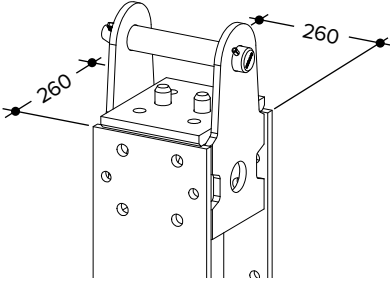
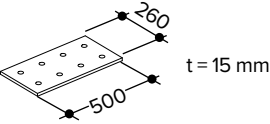

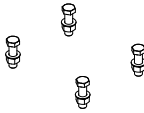
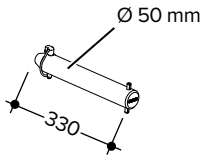
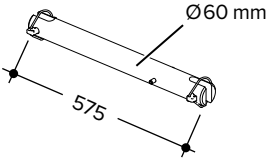
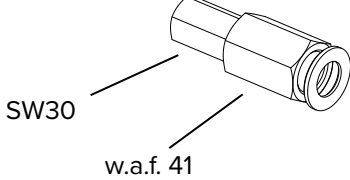
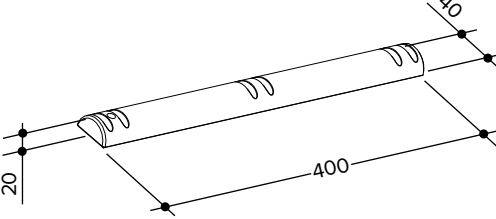
	Component	Part code	Weight [kg]
	Main Beam 62	603670	82.94
	Main Beam 175 cpl.	603728	226.48
	Main Beam 300 cpl.	603709	349.10
	Main Beam 450 cpl.	603710	501.57
	Main Beam 600 cpl.	603711	654.10
	Main Beam cpl. includes Connecting Pin cpl.		
	Main Beam Joint Plate	603673	15.03
		Main Beam Joint Plate Bolt Set¹⁾	603695
Consists of 8no. high tensile bolts M24 x 70 with washer and nut (w.a.f. 41).			

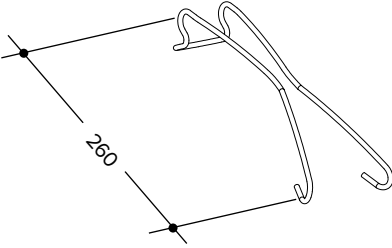
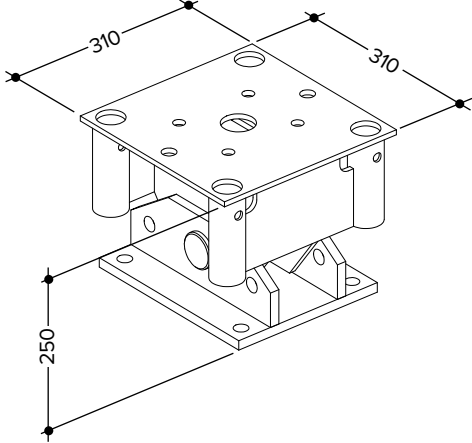
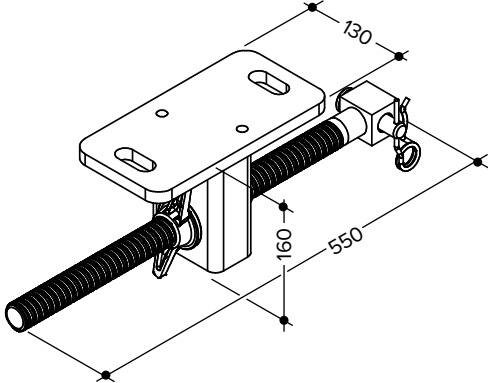
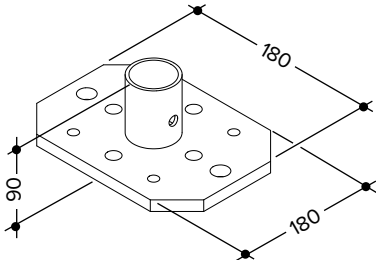
	Component	Part code	Weight [kg]
	<p>Main Beam Joint Bolt Set¹⁾</p> <p>Used to connect two Main Beams at the head. Consists of 4no. high tensile bolts M24 x 85 with washer and nut (w.a.f. 41).</p>	<p>603696</p>	<p>2.82</p>
	<p>Load-bearing Frame Prop Bolt Set¹⁾</p> <p>Used to attach the Load-bearing Frame Prop. Consists of 4no. high tensile bolts M20 x 70 with washer and nut (w.a.f. 32).</p>	<p>603697</p>	<p>1.41</p>
	<p>Connecting Pin cpl.</p> <p>Included in main beam.</p>	<p>603664</p>	<p>6.15</p>
	<p>Tension Bolt cpl.</p> <p>For diagonal bracing with DW 15 Tie Rods.</p> <p>Safe working load $F_{perm} \leq 40.50$ kN</p>	<p>603665</p>	<p>11.68</p>
	<p>Tension Nut Set DW 15¹⁾</p> <p>For preloading of DW 15 Tie Rods in diagonal bracing.</p>	<p>603712</p>	<p>0.70</p>
	<p>Centring Bar 40/20</p> <p>Used for centred transfer of loads from the deck into Main Beams.</p>	<p>603706</p>	<p>1.97</p>

	Component	Part code	Weight [kg]
	C-Clip Used to attach the Centring Bar 40/20 to the Main Beams. Use at least 1no. Clip or up to 3no. Clips per Centring Bar.	603707	0.13
	Pin-jointed Base Plate Used to attach Load-bearing Frame Props / MKII Soldiers to the Main Beam. The Load-bearing Frame Prop Bolt Set (part code:603697) is used to secure the Pin-jointed Base Plate to the Main Beam. The Pin-jointed Base Plate replaces a Prop Jack 2 in a Load-Bearing Frame Prop layout. The Pin-jointed Base Plate allows a 7° inclination of Load-Bearing Frame Props / MK II Soldiers.	603713	35.82
	Adjustable Abutment Bracket Used to secure and align the diagonal brace to the abutment. For every two abutments, one additional Load-bearing Frame Prop Bolt Set (part code:603697) is needed. Safe working load: $F_{perm} \leq 15.00$ kN	603878	8.60
	MK II Spindle Adapter Used to attach the MK II Soldiers. For every two Spindle Adapters, one additional Load-bearing Frame Prop Bolt Set (code:603697) is needed.	603725	5.15

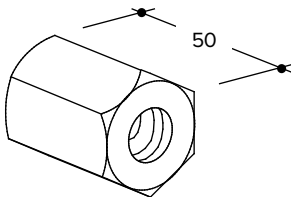
3.2 Accessories INFRA- KIT H

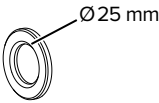
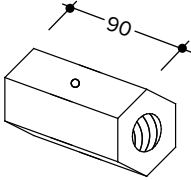
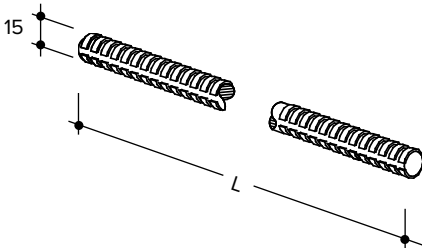
	Component	Part code	Weight [kg]
	Hexagon Nut 15/50¹⁾ To counter the tie rods on the Tension Bolt. Spanner w.a.f. 30 Safe working load: 90 kN	164535	0.21

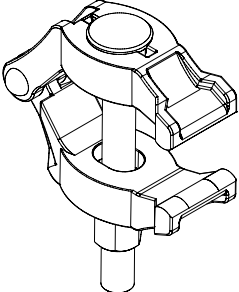
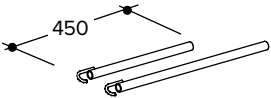
	Component	Part code	Weight [kg]
	Washer 25 Bearing for the Hexagon Nut 15/50 on the Tension Bolt to tense tie rods used in diagonal bracing.	603699	0.03
	Hexagon Nut 15/90 with Pin¹⁾ The Hexagon Nut 15/90 with Pin is used to connect two Tie Rods DW 15. The pin prevents the rod on one side from being inserted too far and the rod on the other side from not being inserted far enough. W.a.f. 30 Safe working load: 90 kN	164546	0.38
	Tie Rod 300 cm¹⁾ (DW 15)	24413	4.32
	Tie Rod 350 cm¹⁾ (DW 15)	24424	5.04
	Tie Rod 400 cm¹⁾ (DW 15)	24435	5.76
	Tie Rod 600 cm¹⁾ (DW 15)	136260	8.64
	Tie Rod DW 15 1 m¹⁾ (DW 15) Safe working load: 90 kN	164811	1.44
	WARNING	Warning! Do not weld or heat Tie Rods. This could cause them to break!	
	Beam Clamp 16/70 Used to connect a Main Beam to a secondary beam in a flexible way. The clamping range is 16 to 70 mm. With a maximum torque of 150.00 Nm, the usable resistance with one friction surface is: 3.00 kN.	603750	1.73
	Scaffold Retainer 75	78940	2.90
	Scaffold Retainer 45 Steel tube Ø48.3 mm with Ø20 cm hook. For tying Load-Bearing Frame Props. Connected to the Prop with Couplers.	78939	1.90

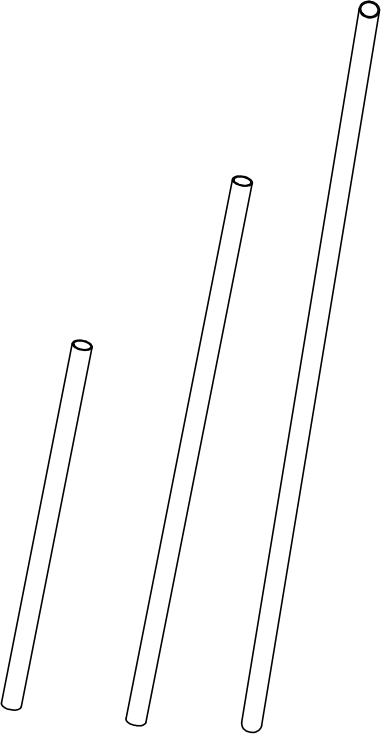
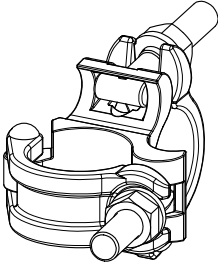
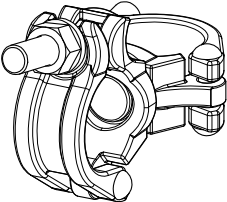
	Component	Part code	Weight [kg]
	Scaffold Tube 48.3 x 50 l = 50 cm	169001	1.90
	Scaffold Tube 48.3 x 100 l = 100 cm	169012	3.81
	Scaffold Tube 48.3 x 150 l = 150 cm	169023	5.72
	Scaffold Tube 48.3 x 200 l = 200 cm	169034	7.62
	Scaffold Tube 48.3 x 250 l = 250 cm	169045	9.53
	Scaffold Tube 48.3 x 300 l = 300 cm	169056	11.43
	Scaffold Tube 48.3 x 350 l = 350 cm	169067	13.34
	Scaffold Tube 48.3 x 400 l = 400 cm	169078	15.24
	Scaffold Tube 48.3 x 450 l = 450 cm	169089	17.15
	Scaffold Tube 48.3 x 500 l = 500 cm	169090	19.05
	Scaffold Tube 48.3 x 550 l = 550 cm	169104	20.96
	Scaffold Tube 48.3 x 600 l = 600 cm	169115	22.86
	Rigid Coupler 48/48 w.a.f. 22 To connect scaffold tubes Ø48.3 right angles. Torque 50 Nm.	2514	1.18
	Swivel Coupler 48/48 w.a.f. 22 To connect scaffold tubes Ø48.3 mm at any angle. Torque 50 Nm.	2525	1.37

	Component	Part code	Weight [kg]
	Half Coupler 48/M 20x30 w.a.f 22 / w.a.f 30	2488	0.90
	Half Coupler 48/M 20x70 w.a.f 22 / w.a.f 30	39846	0.96
	With an additional thread M20×30 mm or M20×70 mm. Torque 50 Nm.		

3.3 INFRA-KIT L and M

	Component	Part code	Weight [kg]
	IK Waler L 62.5	608658	15.72
	IK Waler L 75	608688	18.90
	IK Waler L 100	608700	25.39
	IK Waler L 125	608712	31.73
	IK Waler L 150	608715	38.08
	IK Waler L 200	608720	50.91
	IK Waler L 250	608725	63.75
	IK Waler L 300	608730	76.58
	IK Waler L 350	608735	89.42
	IK Waler L 400	608740	102.25
	IK Waler L 450	608745	115.09
	IK Waler L 500	608750	127.92
	IK Waler L 550	608755	140.75
	Main component of the INFRA-KIT L system. With Spacer Sleeve IK Waler 16-62.		

Components

	Component	Part code	Weight [kg]
	IK Waler M 150	608615	73.79
	IK Waler M 200	608620	98.74
	IK Waler M 250	608625	123.68
	IK Waler M 300	608630	148.63
	IK Waler M 350	608635	173.57
	IK Waler M 400	608640	198.52
	IK Waler M 450	608645	223.46
	IK Waler M 500	608650	248.41
	IK Waler M 550	608655	273.36
	IK Waler M 600	608660	298.31
		Main component of the INFRA-KIT M system. With Spacer Sleeve IK Waler 20-62.	
	IK Spindle 35/50 L (35–50 cm)	608930	8.77
	IK Spindle 50/75 L (50–75 cm)	608950	10.22
	IK Spindle 65/100 L (65–100 cm)	608970	12.14
	IK Spindle 90/155 L (90–155 cm)	608980	16.48
	IK Spindle 140/240 L (140–240 cm)	608990	23.01
		Lightweight spindle used in framework. Connected directly to the IK Waler L/M at the IK Jack or to the Waler Connectors. For safe working load, refer to page 89.	

	Component	Part code	Weight [kg]
	IK Spindle 70/110 (70–110 cm)	608500	15.94
	IK Spindle 100/170 (100–170 cm)	608510	23.13
	IK Spindle 140/240 (140–240 cm)	608520	30.30
	IK Spindle 200/300 (200–300 cm)	608530	36.73
	Adjustable spindle used in framework. Connected directly to the IK Waler L/M at the IK Jack or to the Waler Connectors. For safe working load, refer to page 89.		
	IK Spindle 260/360 (260–360 cm)	608540	44.45
	IK Spindle 320/420 (320–420 cm)	608550	50.89
	IK Spindle 380/480 (380–480 cm)	608560	57.31
	Adjustable spindle used in framework. Connected directly to the IK Waler L/M at the IK Jack or to the Waler Connectors. For safe working load, refer to page 89.		
	IK Waler Connector L	608420	12.84
	Used to create rigid connections between IK Walers L. With connector for IK Spindles.		

	Component	Part code	Weight [kg]
	IK Adapter Waler Connector L Adapter for the IK Waler Connector L. When inserted into the IK Waler L, it allows for additional IK Spindles or IK Walers to be attached. Inserted into the Waler Connector L.	608460	8.07
	IK Cross Connector L Allows IK Spindles to be attached to the web of an IK Waler L.	608450	9.12
	IK Adapter L Used to connect 2no. IK Walers L crosswise or parallel, one on top of the other.	608480	2.27
	IK Waler Connector Flex L For the rigid or articulated connection of IK Waler L to IK Waler L. Or for the articulated connection of IK Waler M to IK Waler L.	608490	8.16
	IK Waler Connector L 25 For the rigid or articulated connection of IK Waler L to IK Waler L.	608445	5.15
	IK Waler Connector M For rigid connection of IK Walers M. Allows additional IK Spindles or IK Walers to be attached.	608430	15.90

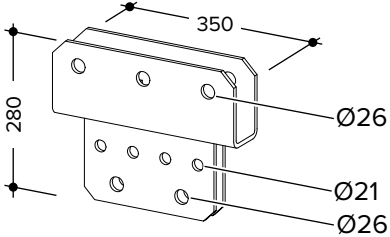
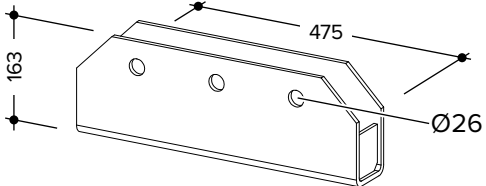
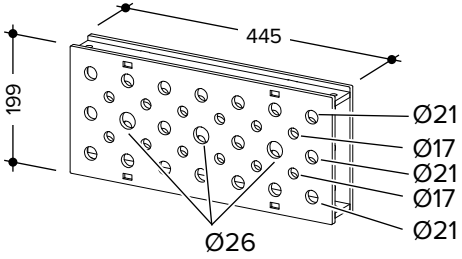
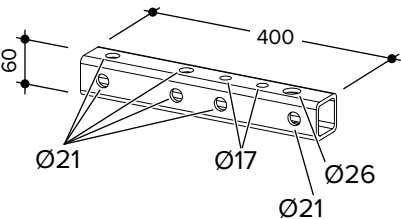
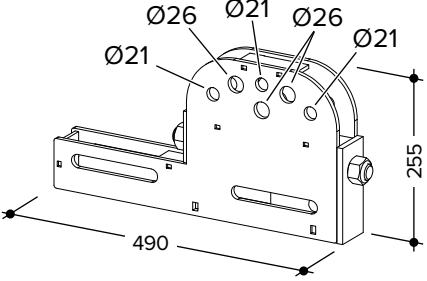
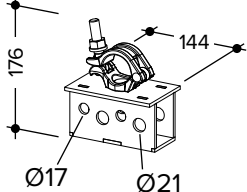
	Component	Part code	Weight [kg]
	<p>IK Adapter Waler Connector M</p> <p>Adapter for the IK Waler Connector M. Allows additional Spindles or Walers to be attached. Inserted into the IK Waler Connector M.</p>	<p>608440</p>	<p>12.08</p>
	<p>IK Cross Connector M</p> <p>Allows IK Spindles to be attached to the web of the IK Waler M.</p>	<p>608470</p>	<p>11.45</p>
	<p>IK Waler Connector Flex M</p> <p>For the rigid or articulated connection of IK Walers M. It also provides an alternative way to attach the IK Waler L to the IK Waler M at right angles</p>	<p>608485</p>	<p>12.85</p>
	<p>IK Adapter M/L</p> <p>Used to connect 2no. IK Walers M crosswise or parallel, one on top of the other. Also used to connect a Waler M to a Waler L.</p>	<p>608770</p>	<p>3.94</p>
	<p>IK Adjustable Connector</p> <p>For articulated connection of Walers outside of the hole grid of the Walers. For IK Waler L and IK Waler M. With integrated adjuster (w.a.f. 36) to adapt node spacing to the dimensions of the structure. Adjustment range +/- 62.5 mm. Refer to page 81.</p>	<p>608850</p>	<p>17.88</p>
	<p>IK Scaffold Tube Adapter</p> <p>Used to attach Ø48.3 mm scaffold tubes to IK Walers L and M. Coupler safe working load (slip): 7.00 kN. Refer to page 95.</p>	<p>608495</p>	<p>2.46</p>

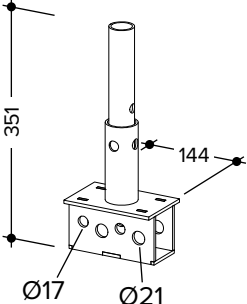
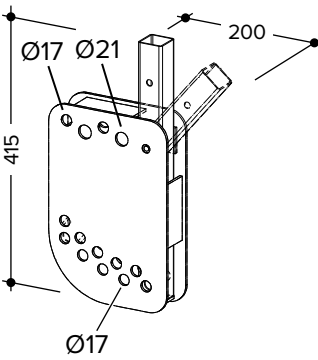
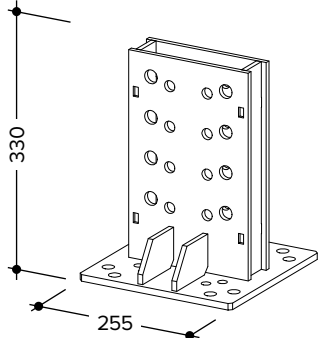
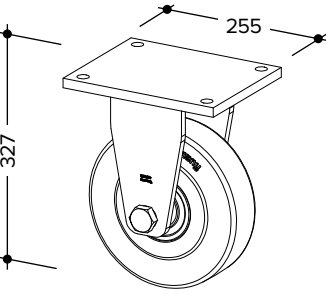
	Component	Part code	Weight [kg]
	<p>Half Coupler 48/M 20×70 w.a.f. 22</p> <p>Used to attach Ø48.3 mm scaffold tubes to IK Walers M. Attached to the flange bores of the IK Waler M. With wedge-shaped washer and nyloc nut.</p> <p>Coupler safe working load (slip): 7.00 kN.</p> <p>Refer to page 96.</p>	608515	1.01
	<p>IK MODEX Adapter</p> <p>Used in conjunction with MODEX components to construct edge protection. Can be used on an IK Waler L or an IK Waler M.</p> <p>Meets the requirements for temporary edge protection systems as specified by DIN EN 13374 - class A.</p> <p>Refer to page 106.</p>	608570	2.65
	<p>IK PROTECTO Adapter</p> <p>Used to secure a PROTECTO Railing Post to an IK Waler L or IK Waler M to construct edge protection.</p> <p>Adjustable 0° - 30° with IK Walers M and 0° - 45° with IK Walers L.</p> <p>Meets the requirements for temporary edge protection systems as specified by DIN EN 13374 - class A.</p> <p>Refer to page 104.</p>	608410	5.44
	<p>IK Wheel Connector L/M</p> <p>Used to attach swivel or fixed castors with a safe working load of 30.00 kN or 60.00 kN to an IK Waler L or an IK Waler M.</p> <p>Refer to page 86 (including for details of the bores).</p>	608600	15.13
	<p>Heavy-duty Fixed Castor Ø200 30 kN</p>	608603	6.80
	<p>Heavy-duty Fixed Castor Ø250 60 kN</p> <p>Rigid castor used with the IK Wheel Connector.</p> <p>Refer to page 87.</p>	608604	19.00

	Component	Part code	Weight [kg]
	Heavy-duty Swivel Castor Ø200 30 kN	608606	9.30
	Heavy-duty Swivel Castor Ø250 60 kN Swivel castor used with the IK Wheel Connector.	608607	25.60

	IK Jack 180 M Used to lift and lower the IK Waler M. The IK Waler M can be attached to the Base Jack horizontally as well as vertically. Safe working load 180.00 kN. Refer to page 85.	608775	36.34
--	---	---------------	--------------

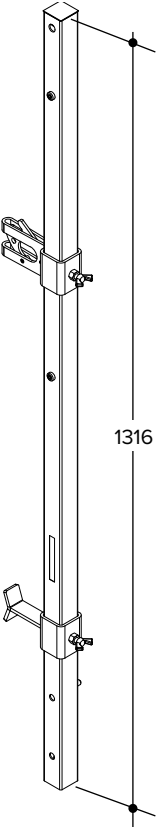
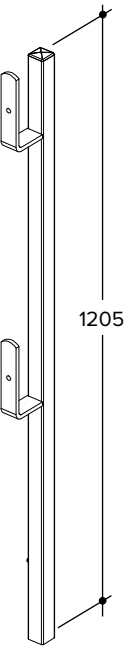
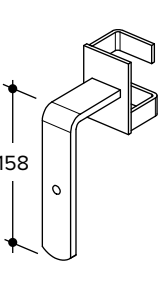

3.4 Accessories INFRA-KIT L and M

	Component	Part code	Weight [kg]
	PROTECTO Panel G2 270	692778	21.00
	PROTECTO Panel G2 240	692772	19.50
	PROTECTO Panel G2 180	692766	14.50
	PROTECTO Panel G2 120	692760	10.00
	Used in combination with the PROTECTO Post 130 Adjustable to provide edge protection. Maximum allowable post spacing is 2.40 m. When used with the PROTECTO Post 130 Adjustable, the PROTECTO Panel G2 complies with BS EN 13374 Class A.		

	Component	Part code	Weight [kg]
	<p>PROTECTO Post 130 Adjustable</p> <p>The PROTECTO Post 130 Adjustable is used in combination with the PROTECTO Panel G2.</p> <p>An integrated safety device secures the post automatically to the various retaining elements.</p> <p>The PROTECTO Post 130 Adjustable complies with BS EN 13374 Class A when used with the PROTECTO Panels G2.</p>	<p>692750</p>	<p>3.67</p>
	<p>PROTECTO railing post</p> <p>The PROTECTO Railing Post is used in conjunction with plank railings (see page 102). An integrated safety device secures the post automatically to the various retaining elements (see page 23).</p> <p>The PROTECTO Railing Post complies with EN 13374 when used with plank railings. The planks used for railing must be 30 mm thick, 150 mm high and meet the requirements of strength class C24 according to EN 338 (formerly S10).</p>	<p>601225</p>	<p>3.65</p>
	<p>PROTECTO Toeboard Retainer</p> <p>Used with the PROTECTO Railing Post, this add-on secures the toeboard when using plank railings.</p> <p>The PROTECTO Toeboard Retainer can easily be attached to PROTECTO Railing Posts which have been already installed.</p>	<p>601227</p>	<p>0.69</p>

	Component	Part code	Weight [kg]
	PROTECTO Post Extension 26	602111	0.96
	PROTECTO Post Extension 42	602580	1.21
	<p>The PROTECTO Post Extensions are used to increase the height of the PROTECTO posts by 260 mm or 420 mm.</p> <p>The maximum spacing of the PROTECTO Post Extension 26 is 1.70 m, whereas the maximum spacing for the PROTECTO Post Extension 42 is 1.30 m.</p>		
	IK Pin Ø16	608816	0.31
	IK Pin Ø20	608820	0.49
	IK Pin Ø25	608825	0.78
	<p>Used to connect IK L and IK M components.</p> <p>Always secure with Spring Cotter Pins.</p>		
	Spring Cotter Pin Ø4	173776	0.02
	Spring Cotter Pin Ø5	174553	0.04
	<p>Used to secure IK Pins Ø16 and Ø20.</p> <p>Used to secure IK Pins Ø25.</p>		
	Hexagon Bolt M16 × 120 10.9, galv.¹⁾	608662	0.22
	Hexagon Bolt M20 × 130 10.9, galv.¹⁾	608663	0.37
	Hexagon Bolt M24 × 130 10.9, galv.¹⁾	608664	0.56
	Hexagon Nyloc Nut M16-10, galv.¹⁾	608703	0.04
	Hexagon Nyloc Nut M20-10, galv.¹⁾	608618	0.06
	Hexagon Nyloc Nut M24-10, galv.¹⁾	608667	0.09
	<p>Used for tension-resistant connection of IK L and IK M components.</p>		
	Hexagon Bolt M16 × 100 8.8, galv.¹⁾	608702	0.19
	Hexagon Bolt M20 × 110 8.8, galv.¹⁾	608617	0.33
	Hexagon Nyloc Nut M16-8, galv.¹⁾	608703	0.04
	Hexagon Nyloc Nut M20-8, galv.¹⁾	608618	0.06
	<p>Use to connect the U-profiles of Walers L and M.</p>		

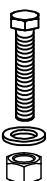
Components

	Component	Part code	Weight [kg]
<div style="display: flex; justify-content: space-around;"> <div style="text-align: center;"> <p>M16 w.a.f. 24</p>  </div> <div style="text-align: center;"> <p>M12 w.a.f. 18/19</p>  </div> </div>	Hexagon Bolt M12 × 65 10.9, galv. ¹⁾	608627	0.06
	Hexagon Bolt M16 × 65 10.9, galv. ¹⁾	608628	0.12
	Hexagon Nyloc Nut M12-10, galv. ¹⁾	608622	0.01
	Hexagon Nyloc Nut M16-10, galv. ¹⁾	608703	0.04
	Washer 12-200 ¹⁾	608632	0.01
	Washer 16-200 ¹⁾	608633	0.01
Used to connect the Heavy-duty Castors to the IK Wheel Connector L/M			
<div style="display: flex; justify-content: space-around;">   </div>	Spacer Sleeve IK Waler L ¹⁾	608496	0.05
	Spacer Sleeve IK Waler M ¹⁾	608498	0.10

4 Component dimensions

4.1 INFRA-KIT H

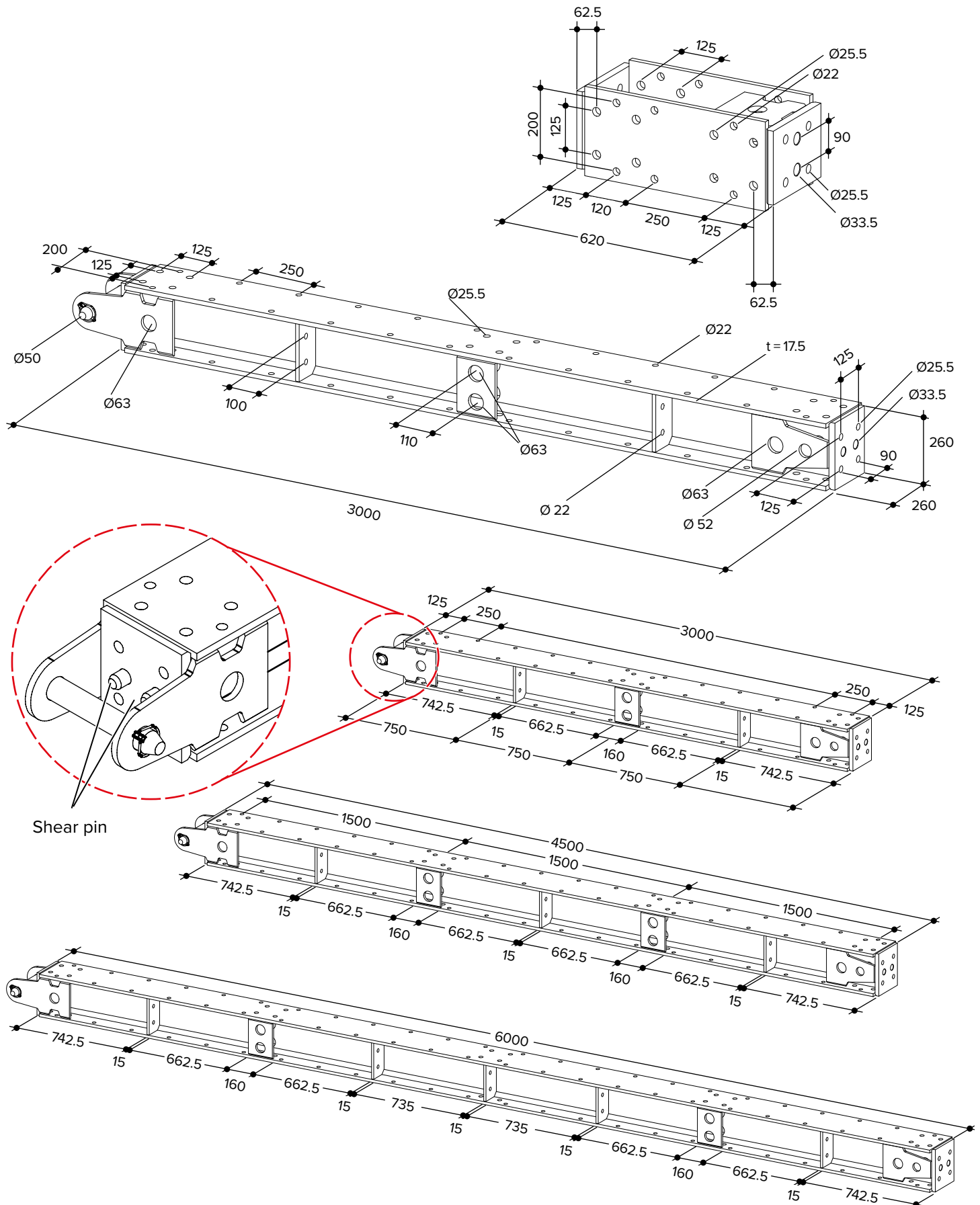

Shear pin

4.2 INFRA-KIT M

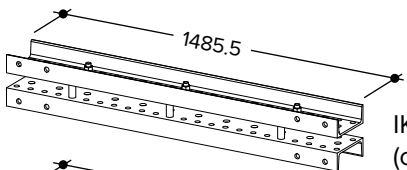
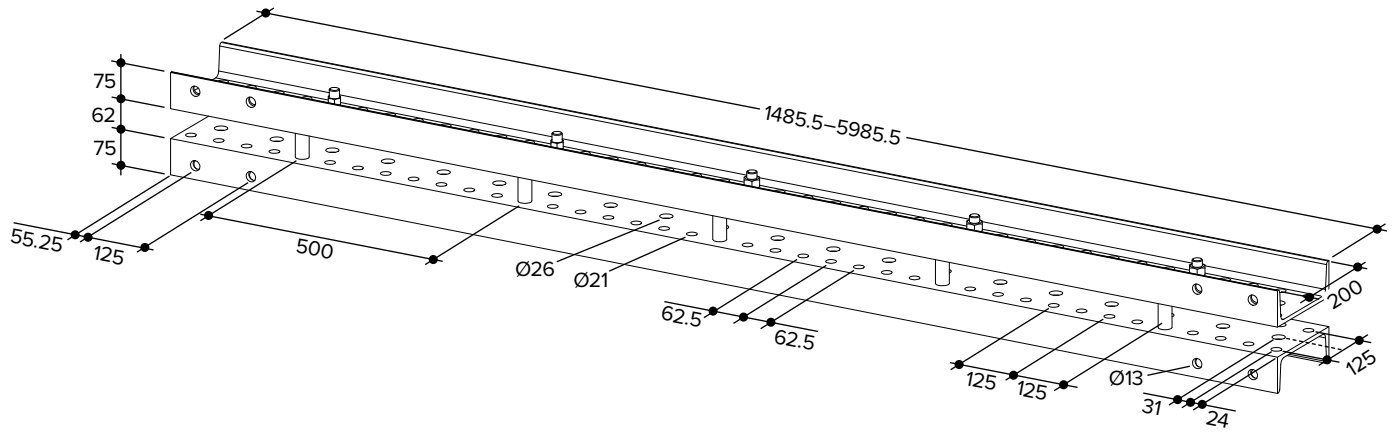

IK Waler M 150
(code:608615)

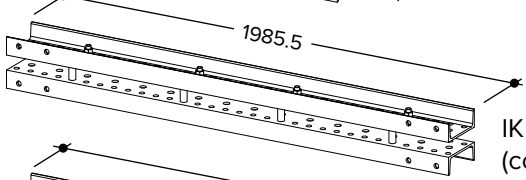

IK Waler M 200
(code:608620)

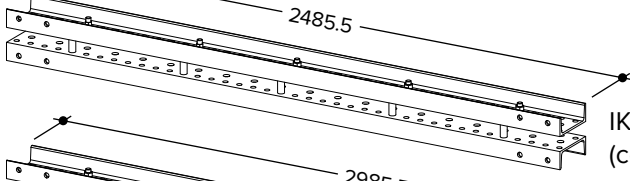

IK Waler M 250
(code:608625)

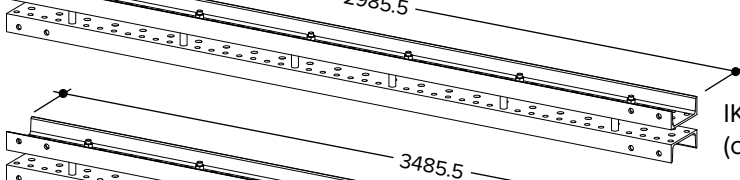

IK Waler M 300
(code:608630)

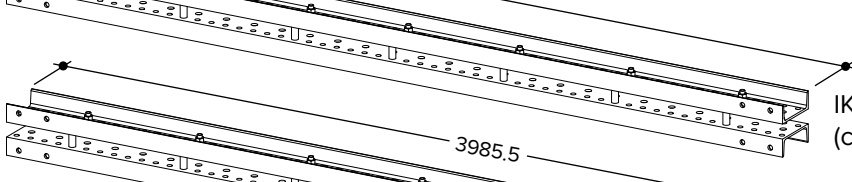

IK Waler M 350
(code:608635)

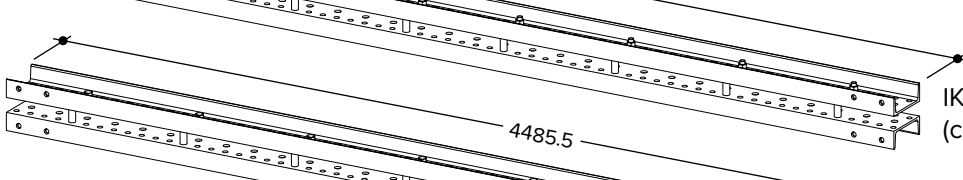

IK Waler M 400
(code:608640)

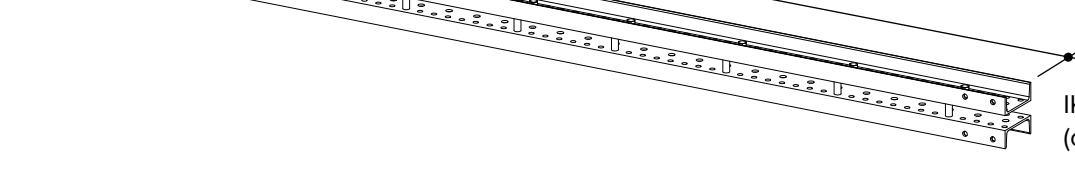

IK Waler M 450
(code:608645)

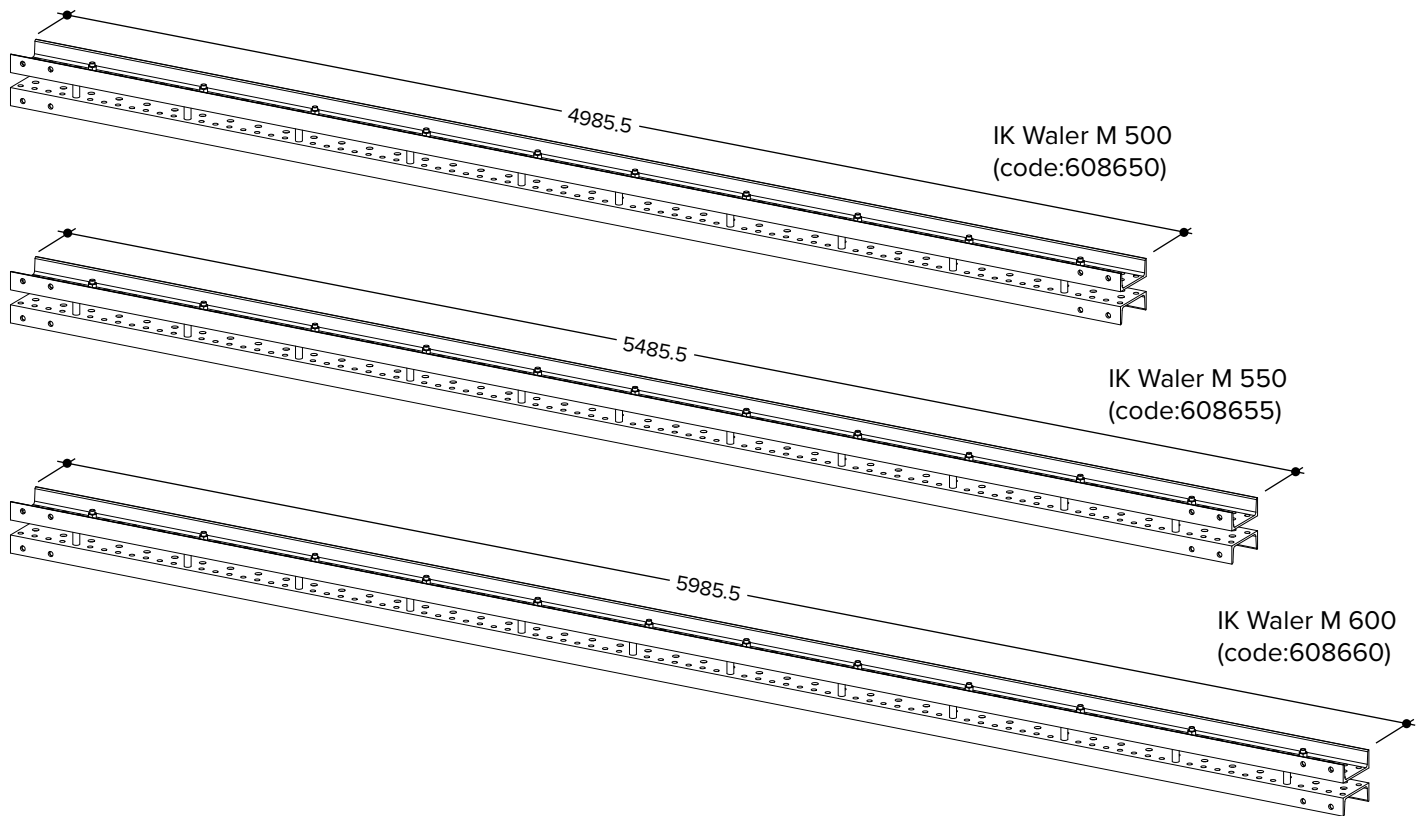

4.3 INFRA-KIT L

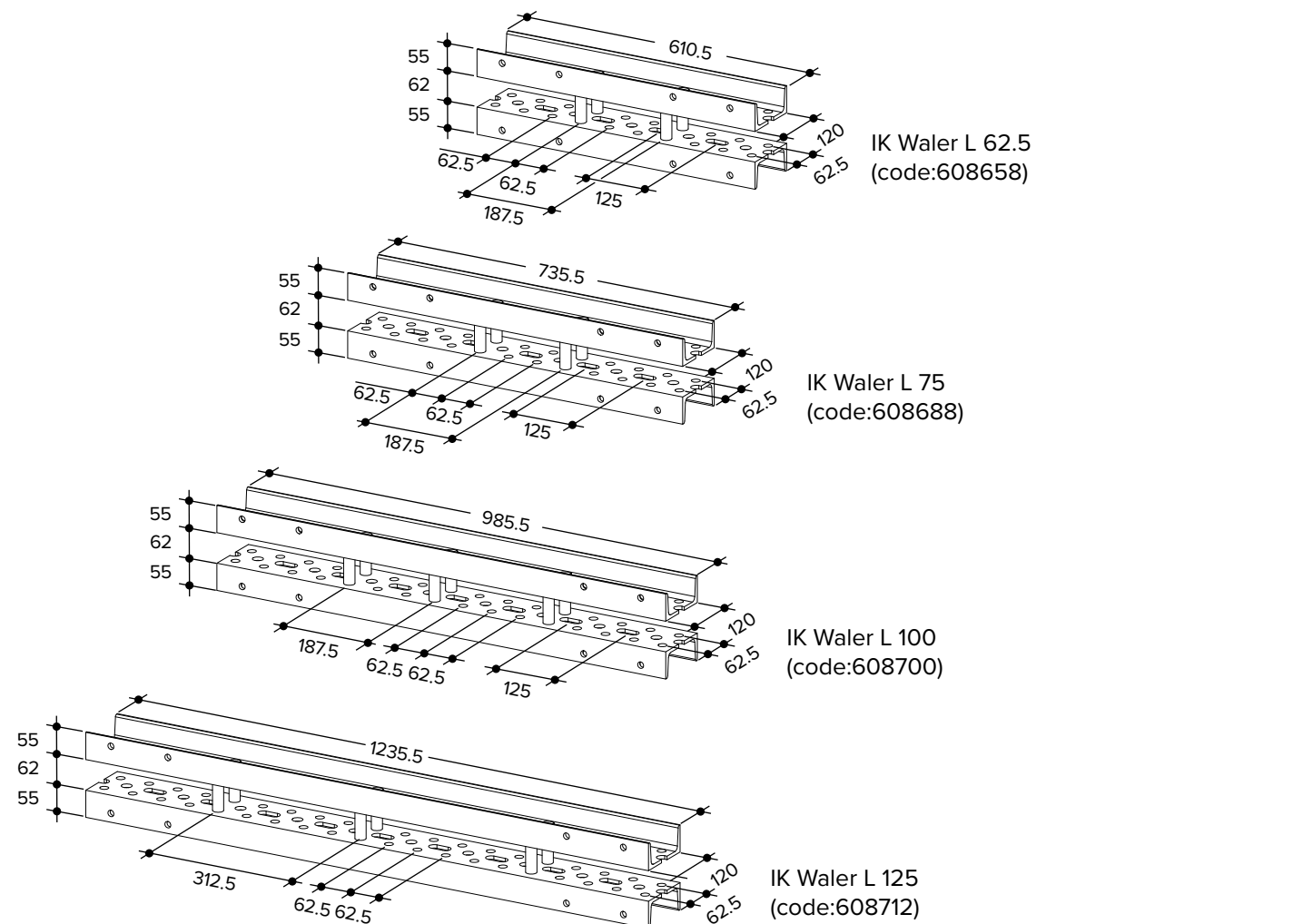

Component dimensions

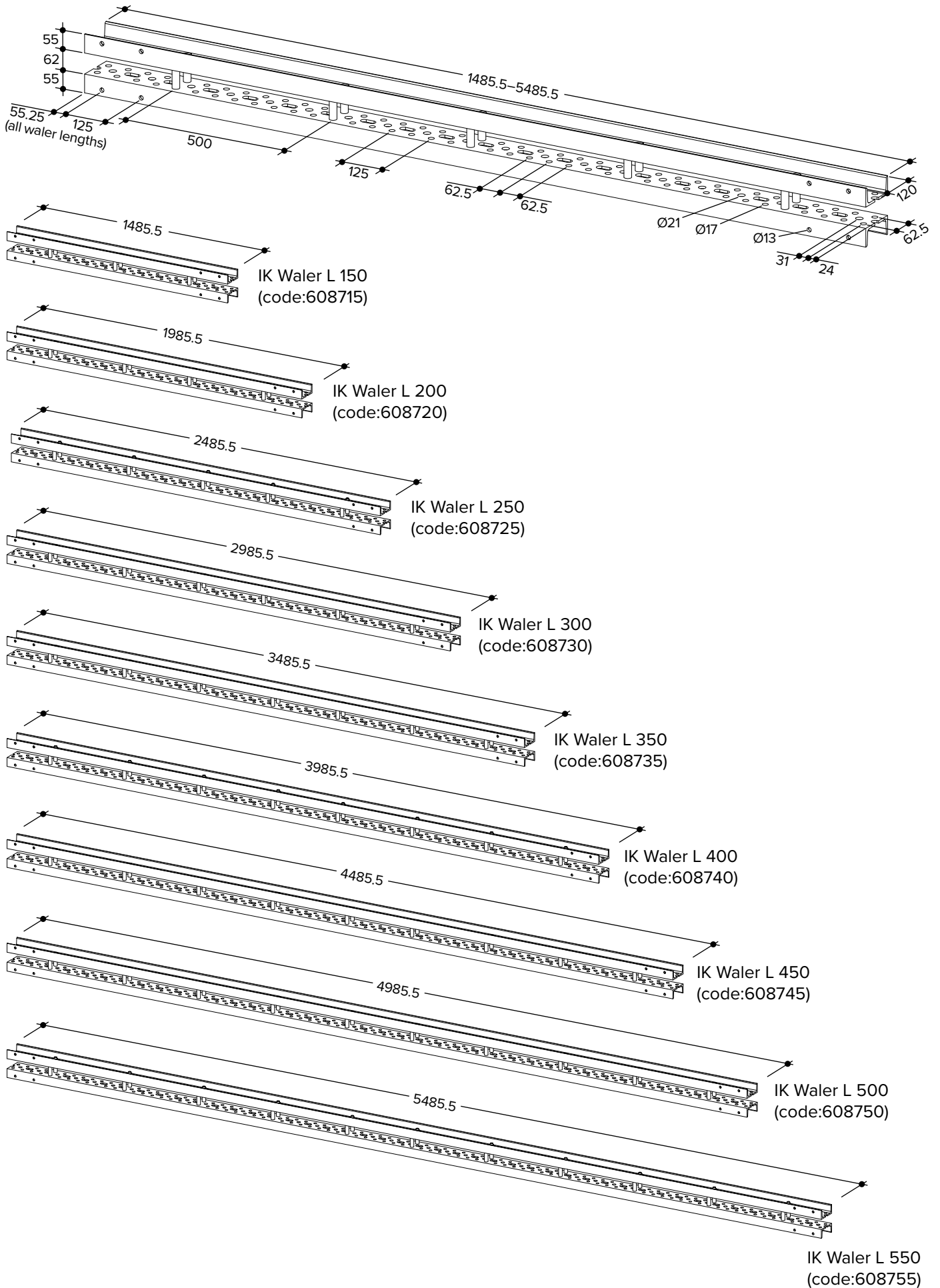

5 Connecting Beams INFRA-KIT H

The following illustrations show the different beam connections possible with INFRA-KIT Beams.

Note that the examples shown below are only applicable when axial (*) loads do not exceed 100.00 kN.

Waler connection using Connecting Pin (normally connected in the vertical truss)

(with integrated shear pin)

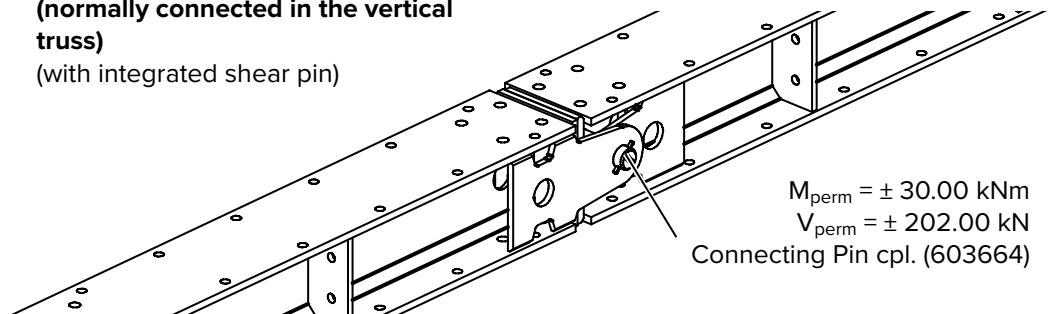

$M_{perm} = \pm 30.00 \text{ kNm}$
 $V_{perm} = \pm 202.00 \text{ kN}$
 Connecting Pin cpl. (603664)

Waler joint with Bolts (with integrated shear pin) Without Connecting Pin

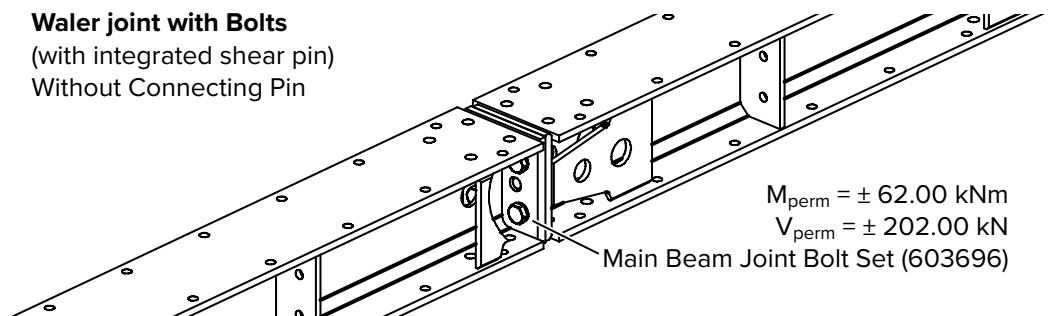

$M_{perm} = \pm 62.00 \text{ kNm}$
 $V_{perm} = \pm 202.00 \text{ kN}$
 Main Beam Joint Bolt Set (603696)

Waler joint with Main Beam Joint Plate and Bolts (with integrated shear pin)

(with integrated shear pin)

Bolt Set (603695)
 Main Beam Joint Plate (603673)

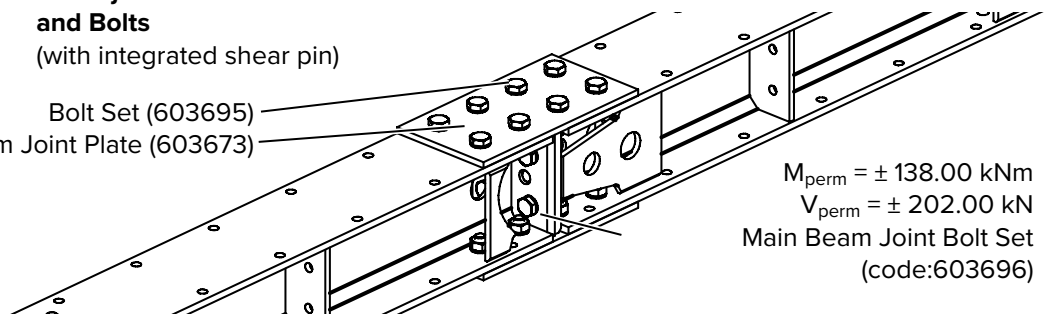

$M_{perm} = \pm 138.00 \text{ kNm}$
 $V_{perm} = \pm 202.00 \text{ kN}$
 Main Beam Joint Bolt Set
 (code:603696)

Head plate joint with Bolts (without shear pin) With Joint Plate Bolt Set (603696)

(without shear pin)
 With Joint Plate Bolt Set (603696)

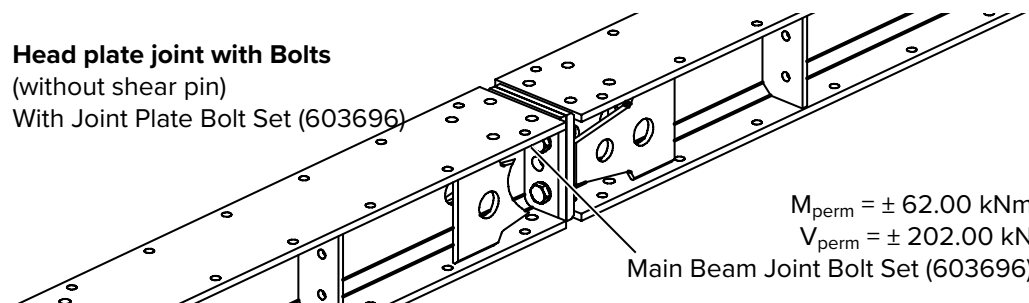

$M_{perm} = \pm 62.00 \text{ kNm}$
 $V_{perm} = \pm 202.00 \text{ kN}$
 Main Beam Joint Bolt Set (603696)

6 General Information on IK Walers L and M

The IK Walers L and M consist of two U-profiles connected to one another using Waler Bolts and Spacer Sleeves (Refer to section 8.1).

There are holes in the webs of the Walers. Connectors, Spindles and other components can be attached at the holes using the IK Pins.



WARNING

Connection can fail!

Bolts 8.8 have a lower SWL than IK Pins or bolts 10.9.

Using bolts 8.8 when the structure is subjected to the same load can cause connections to fail and the structure to collapse!

Keep in mind the reduced SWL (Refer to section 7.17 on page 46)!



The horizontal line in the H on the pin's head is aligned with the hole for the Spring Cotter Pin.



Bolts 10.9 of the respective diameter can be used instead for every connection shown with IK Pins! This does not change the SWL of the connections.

There are also holes in the flanges at the ends of the IK Walers M. They can be used e.g. to attach half couplers for scaffold tubes.

6.1 Orientation of Walers

The web holes of the Walers are made from one side of the flange with a precise dimension. Because of the manufacturing process, the tolerances are somewhat higher from the other side of the flange.

On INFRA-KIT **Walers L**, the exact side of the flange is always the side **with** holes in the flanges.

On INFRA-KIT **Walers M**, the exact side of the flange is always the side **without** holes in the flanges.

6.1.1 Identification mark

Waler L

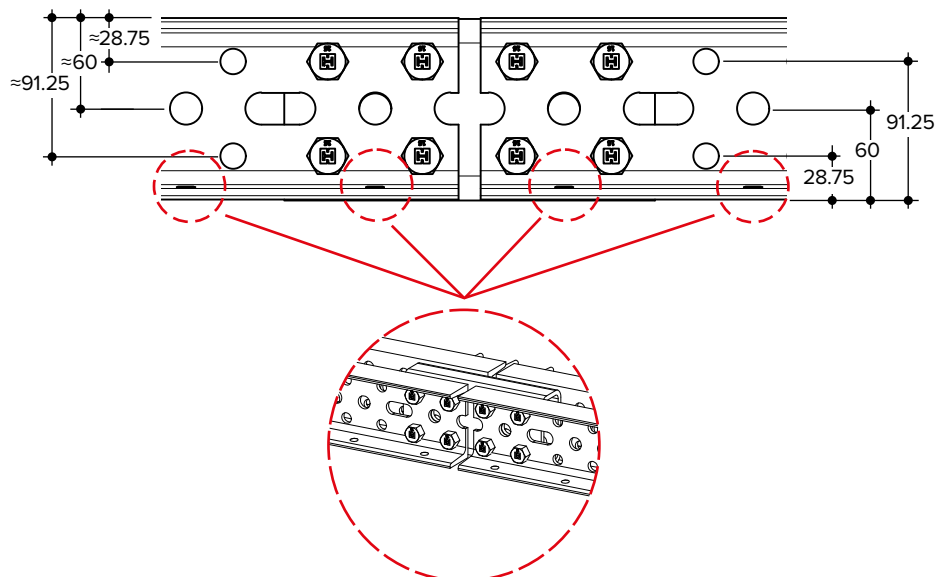

Waler M

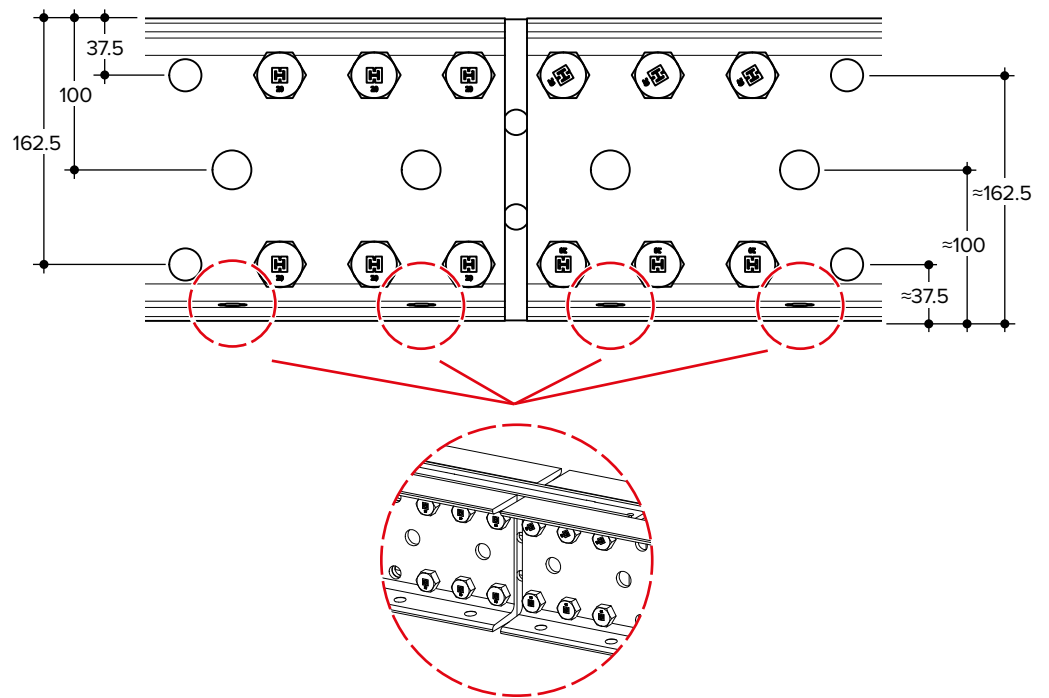

6.1.2 Orientation

When walers are connected to one another, always verify that the the exact side faces are in the same direction. This is particularly important e.g. if formwork constructed of square timbers has to rest on the walers (example **A**) or the walers have to be precisely positioned on a support (e.g. IK Jack 180) (example **B**). The following illustrations show Walers M. The respective requirements apply to Walers L (be sure to use the correct side).

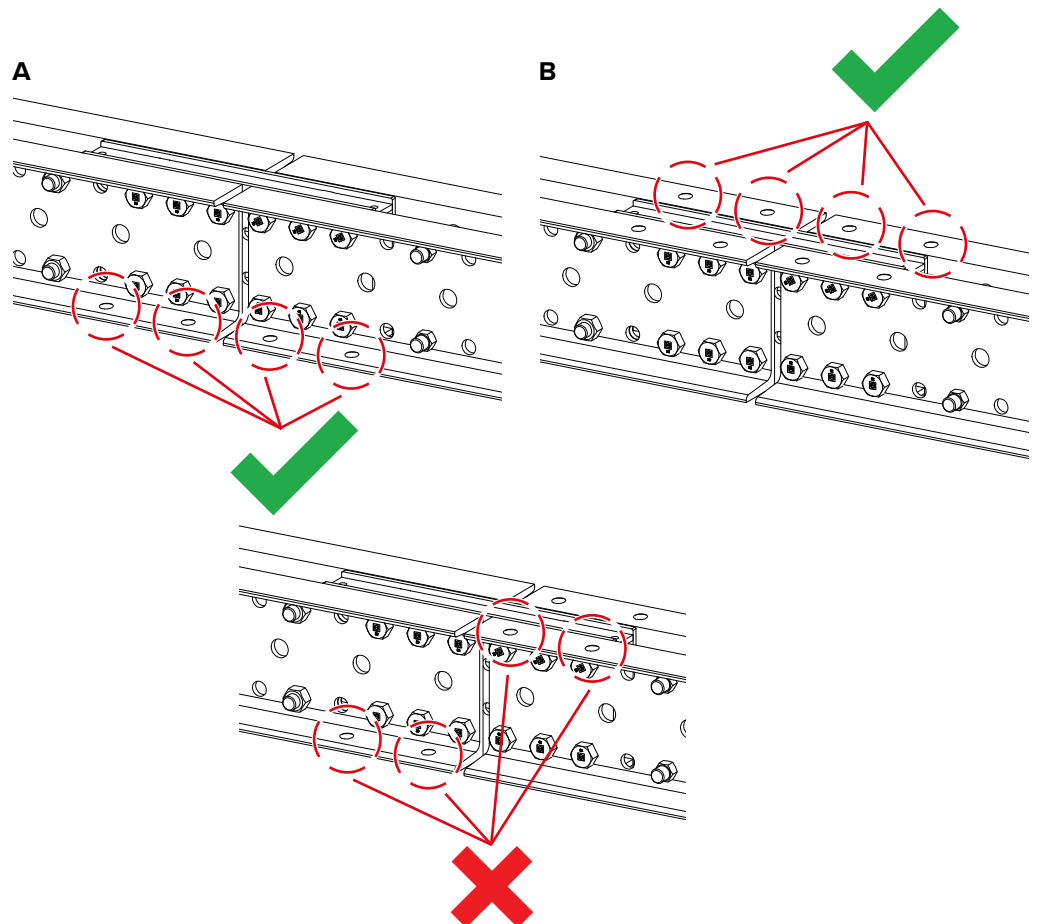

7 Structural information



WARNING

Connection can fail!

The SWL of connected parts may be limited by the SWL of one of its components!

Overloading components can cause the structure to fail!

This can cause personal injury or death!

Comply with the SWLs of all components connected!

Always use the lowest SWL as a reference!

7.1 Walers L

7.1.1 SWL plastic moment

$$N_{pl, perm.} = 487.00 \text{ kN}$$

$$V_{pl, z, perm.} = 104.00 \text{ kN}$$

$$M_{pl, y, perm.} = 21.77 \text{ kNm}$$

Linear interaction can be used for
SWL plastic moment verification

7.1.2 Cross section values

$$A_{tot} = 29.21 \text{ cm}^2$$

$$A_z = 10.85 \text{ cm}^2$$

$$w_{el, y} = 113.48 \text{ cm}^3$$

$$I_y = 680.88 \text{ cm}^4$$

$$A_{y, red} = 9.34 \text{ cm}^2$$

$$w_{el, z} = 90.87 \text{ cm}^3$$

$$I_{z, red} = 77.16 \text{ cm}^4$$



An elastic stress analysis is recommended for beams subjected to compressive loads, with partial safety factors $\gamma_M = 1,1$ - and $\gamma_F = 1,5$ - for S275.

Comply with proof of structural stability for beams subjected to mechanical strain!

Use lateral restraint to counter torsional buckling!

7.1.3 Pin load ratings

$$\text{IK Pin } \varnothing 16 \text{ } F_{perm} = 62.00 \text{ kN}$$

$$\text{IK Pin } \varnothing 20 \text{ } F_{perm} = 77.00 \text{ kN}$$

7.1.4 Load ratings of standard pin arrangements

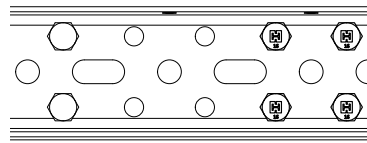

4no. IK Pins Ø16

$M_{perm} = 10.90 \text{ kNm}$
 F_{hperm} and $F_{vperm} = 246.00 \text{ kN}$

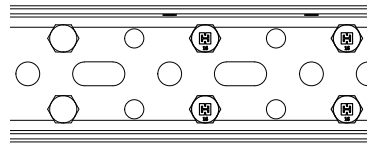

4no. IK Pins Ø16

$M_{perm} = 17.22 \text{ kNm}$
 F_{hperm} and $F_{vperm} = 246.00 \text{ kN}$

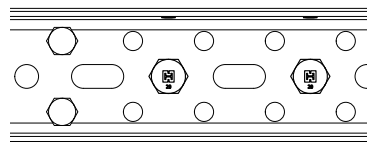

2no. IK Pins Ø20

$M_{perm} = 9.63 \text{ kNm}$
 F_{hperm} and $F_{vperm} = 154.00 \text{ kN}$

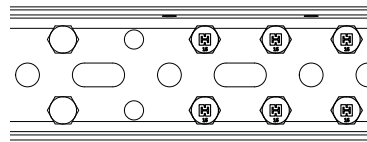

6no. IK Pins Ø16

$M_{perm} = 18.94 \text{ kNm}$
 F_{hperm} and $F_{vperm} = 370.00 \text{ kN}$

Interaction equation:

$$\frac{M}{M_{zul.}} + \sqrt{\left[\frac{F_H}{F_{H,zul.}}\right]^2 + \left[\frac{F_V}{F_{V,zul.}}\right]^2} \leq 1,0$$

7.1.5 Compressive load capacity of Waler L

Length of Waler [m]	Permitted compression force [kN] in IK Waler L with pinned bearing conditions (Euler case II)
3.00	214
3.50	191
4.00	135
4.50	121
5.00	105

7.2 Walers M

7.2.1 SWL plastic moment

$N_{pl, perm.} = 1228.00 \text{ kN}$ Linear interaction can be used for
 $V_{pl, z, perm.} = 310.00 \text{ kN}$ SWL plastic moment verification
 $M_{pl, y, perm.} = 88.44 \text{ kNm}$

7.2.2 Cross section values

$A_{tot} = 57.09 \text{ cm}^2$ $A_{y, red} = 16.34 \text{ cm}^2$
 $A_z = 24.98 \text{ cm}^2$ $w_{el, z} = 177.99 \text{ cm}^3$
 $w_{el, y} = 352.86 \text{ cm}^3$ $I_{z, red} = 274.09 \text{ cm}^4$
 $I_y = 3528.61 \text{ cm}^4$



An elastic stress analysis is recommended for walers subjected to compressive loads, with partial safety factors $\gamma_M = 1,1$ - and $\gamma_F = 1,5$ - for S355.
 Comply with proof of structural stability for beams subjected to mechanical strain!
 Use lateral restraint to counter torsional buckling.

7.2.3 Pin load ratings

IK Pin $\varnothing 20$ $F_{perm} = 108.00 \text{ kN}$
 IK Pin $\varnothing 25$ $F_{perm} = 142.00 \text{ kN}$

7.2.4 Load ratings of standard pin arrangements

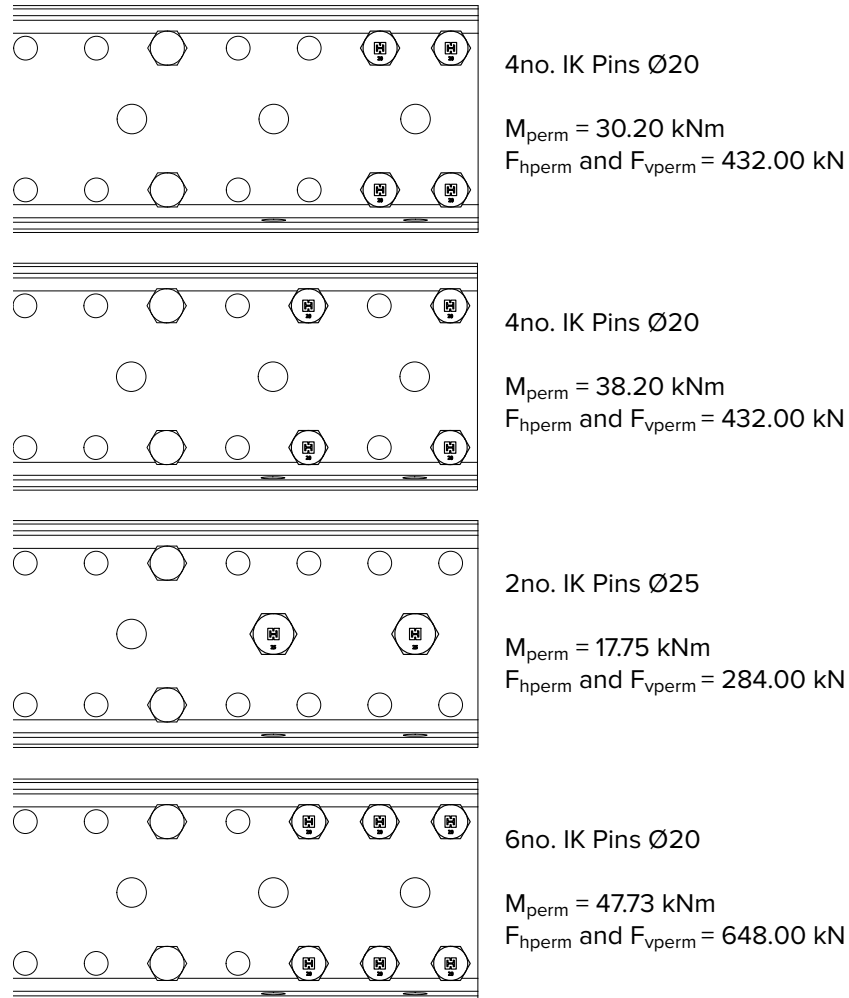

Interaction equation:

$$\frac{M}{M_{zul.}} + \sqrt{\left[\frac{F_H}{F_{H,zul.}}\right]^2 + \left[\frac{F_V}{F_{V,zul.}}\right]^2} \leq 1,0$$

7.2.5 Compressive load capacity of Waler M

Length of Waler [m]	Permitted compression force [kN] in IK Waler M with pinned bearing conditions (Euler case II)
3.00	587
3.50	528
4.00	427
4.50	390
5.00	346

7.3 IK Waler Connector L (code:608420)

Stress resultant limits

$N_{pl, perm.} = 619.00 \text{ kN}$

$V_{pl, z, perm.} = 462.00 \text{ kN}$

$M_{pl, y, perm.} = 34.00 \text{ kNm}$

Linear interaction can be used for cross-section verification.

Permitted load ratings of holes when connecting 3no. IK Spindles

Attach IK Spindles only at the angles shown here!
Always use 12no. IK Pins Ø16 to secure an IK Waler Connector L.

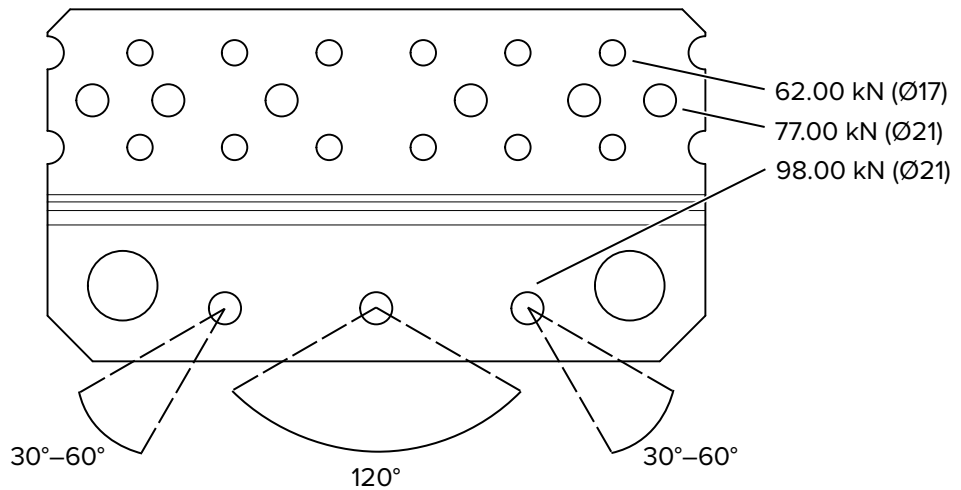

7.4 IK Adapter Waler Connector L (code:608460)

Stress resultant limits

$$N_{pl, perm.} = 364.00 \text{ kN}$$

$$V_{pl, z, perm.} = 223.00 \text{ kN}$$

$$M_{pl, y, perm.} = 9.74 \text{ kNm}$$

Linear interaction can be used for cross-section verification.

Permitted load ratings of holes when connecting 1no. IK Spindle



Attach IK Spindles only at the angles shown here!

Always use 8no. IK Pins Ø16 to secure an IK Adapter Waler Connector L.

When IK Waler Connectors L and IK Adapters Waler Connector L are used together, do not exceed the permitted bolt forces when attaching Waler L!

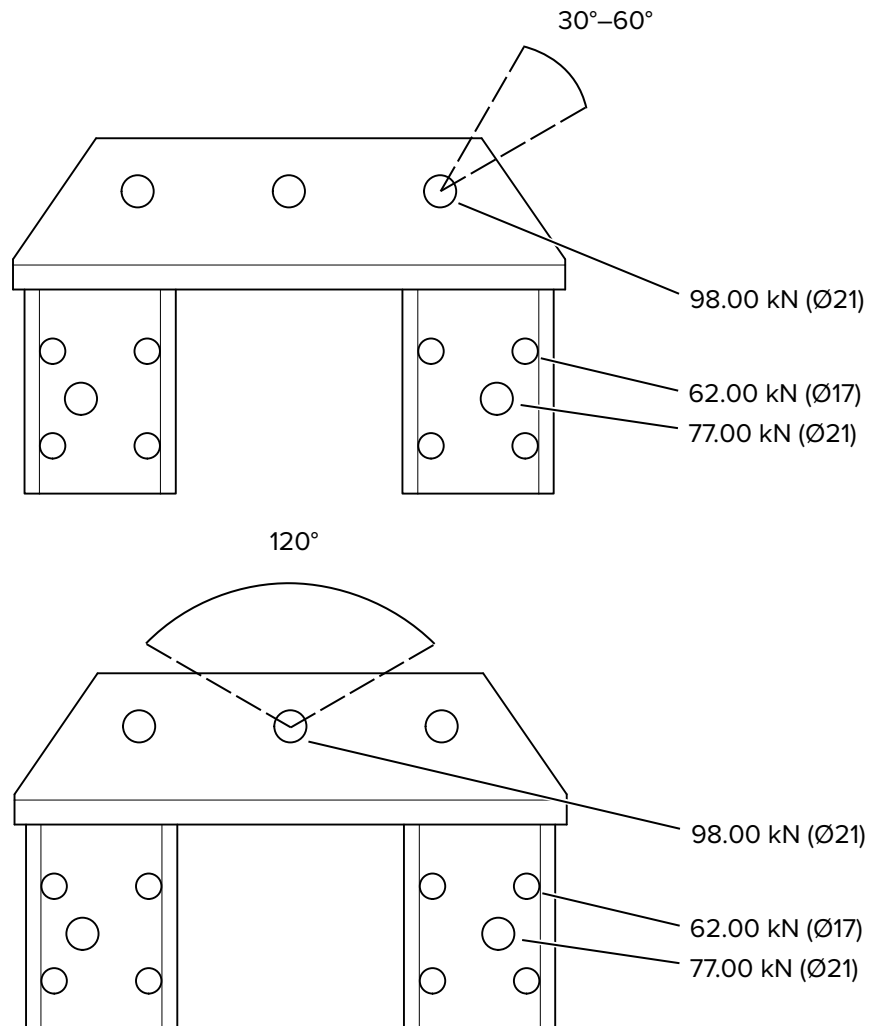

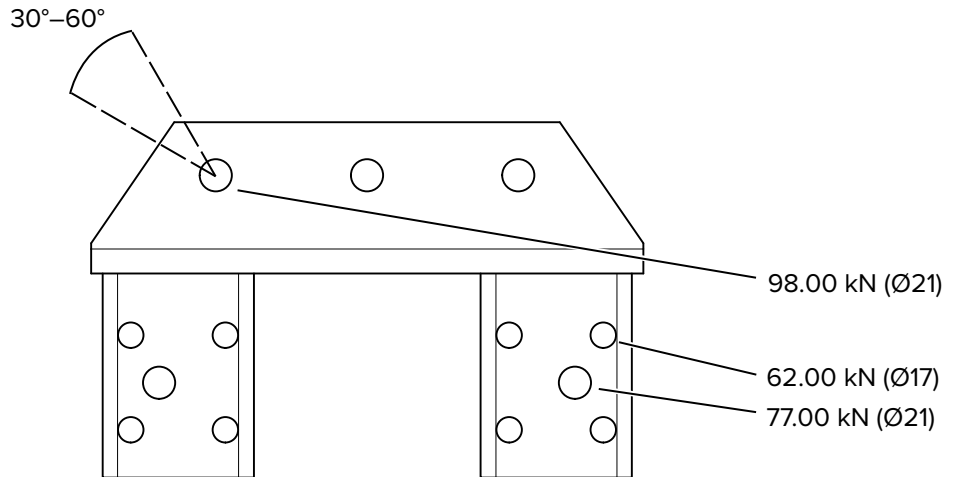

Permitted load ratings of holes when connecting 3no. IK Spindles



Attach IK Spindles only at the angles shown here!

Always use 8no. IK Pins Ø16 to secure an IK Adapter Waler Connector L.

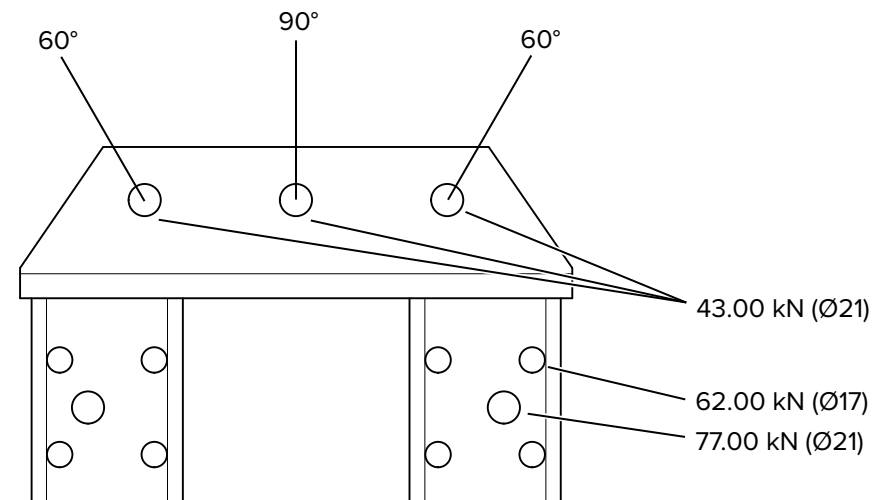
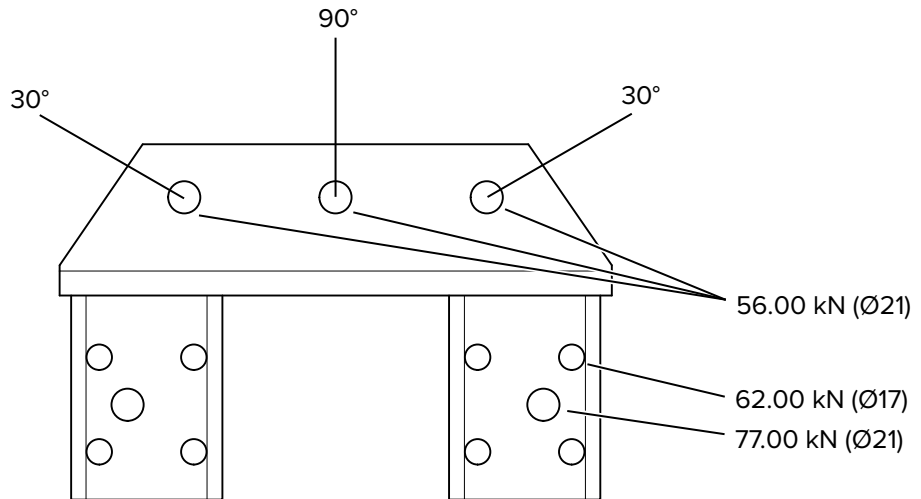

Linear interpolation can be applied to determine the load rating for angles between 30° and 60°.

7.5 IK Waler Connector L 25 (code:608445)

Stress resultant limits

$$N_{pl, perm.} = 444.00 \text{ kN}$$

$$V_{pl, z, perm.} = 237.00 \text{ kN}$$

$$M_{pl, y, perm.} = 15.72 \text{ kNm}$$

Linear interaction can be used for cross-section verification.

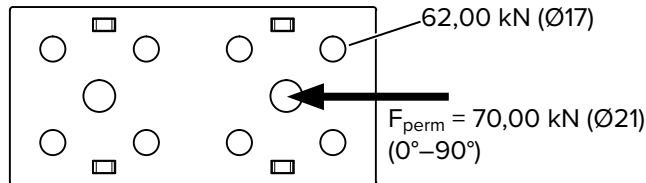

Always use 4no. IK Pins Ø16 to secure an IK Waler Connector L to the IK Waler L!

The maximum permitted bending moment M_{perm} when using 4no. IK Pins Ø16 is 10.90 kNm! Check if pin can withstand the imposed loads!

7.6 IK Waler Connector Flex L (code:608490)

Stress resultant limits

$$N_{pl, perm.} = 444.00 \text{ kN}$$

$$V_{pl, z, perm.} = 237.00 \text{ kN}$$

$$M_{pl, y, perm.} = 15.72 \text{ kNm}$$

Linear interaction can be used for cross-section verification.

Permitted load ratings of holes



Always use 6no. IK Pins Ø16 to secure an IK Waler Connector Flex L to the IK Waler L!

The maximum permitted bending moment M_{perm} when using 6no. IK Pins Ø16 is 15.72 kNm!

Check if pin can withstand the imposed loads!

Linear interpolation can be applied to determine angles between 0° and 90°!

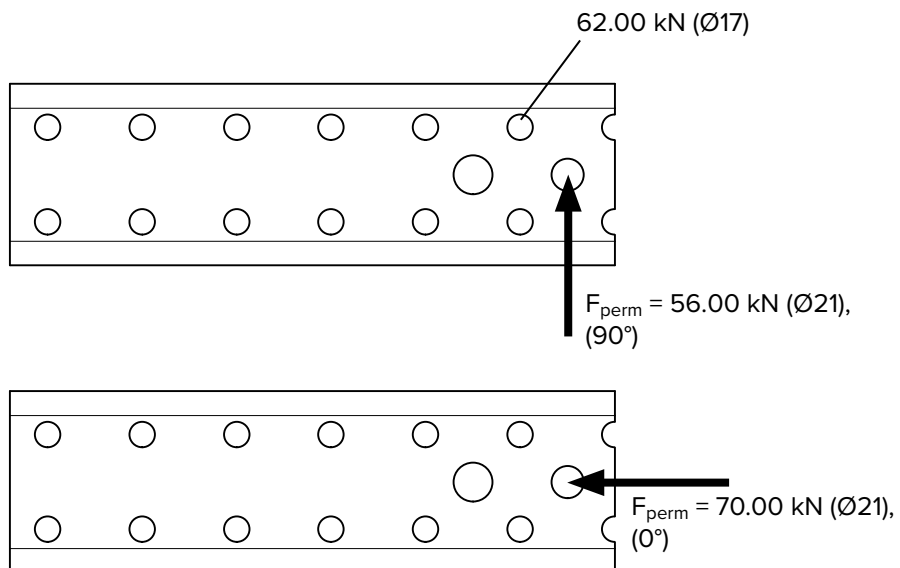

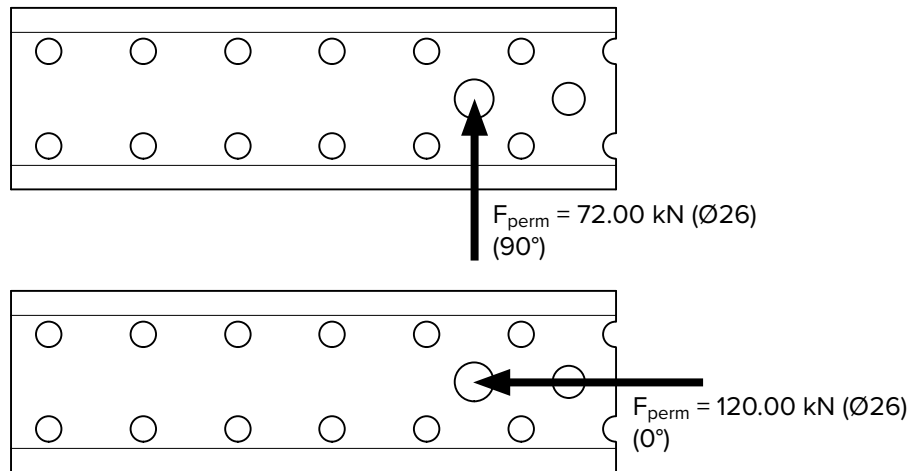

7.7 IK Cross Connector L (code:608450)

Stress resultant limits

$N_{pl, perm.} = 481.00 \text{ kN}$

$V_{pl, z, perm.} = 259.00 \text{ kN}$

$M_{pl, y, perm.} = 16.97 \text{ kNm}$

Linear interaction can be used for cross-section verification.

Permitted load ratings of holes when connecting 1no. IK Spindle

Attach IK Spindles only at the angles shown here!
Always use 4no. Bolts M20 × 130 (code:608456) to secure the IK Cross Connector L!

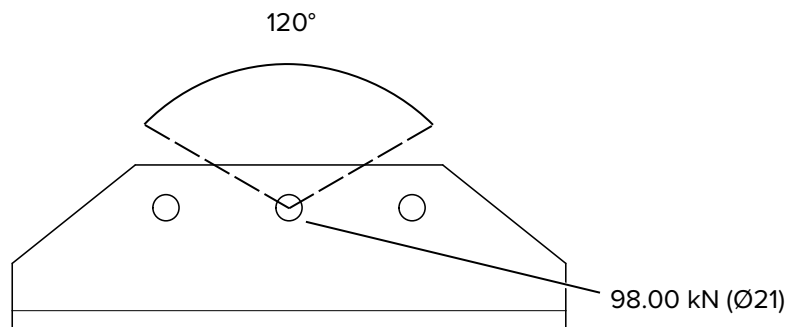
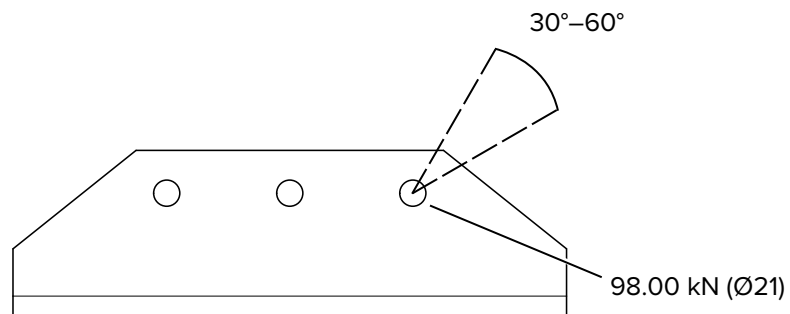

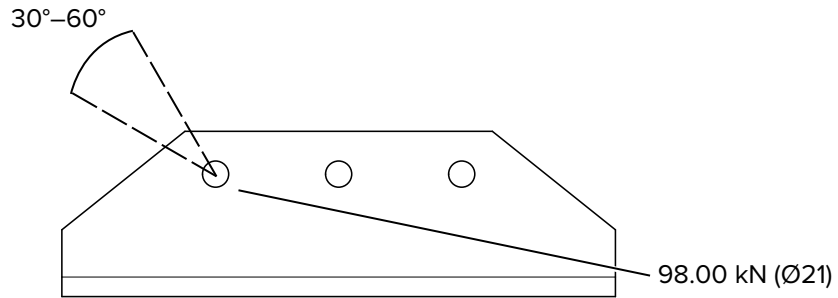

Permitted load ratings of holes when connecting 3no. IK Spindles



Attach IK Spindles only at the angles shown here!

Always use 4no. Bolts M20 × 130 (code:608456) to secure the IK Cross Connector L!

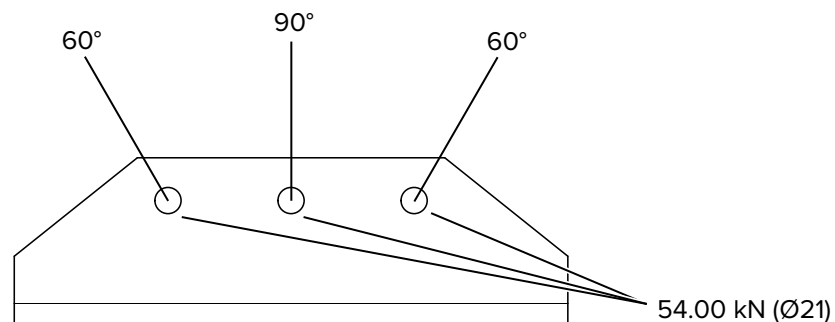
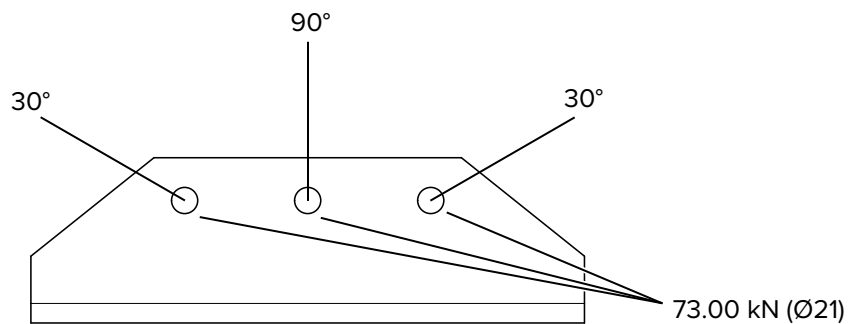

Linear interpolation can be applied to determine the load rating for angles between 30° and 60°.

7.8 IK Adapter L (code:608480)

Stress resultant limits

$$N_{pl, perm.} = 171.00 \text{ kN}$$

$$V_{pl, z, perm.} = 56.00 \text{ kN}$$

$$M_{pl, y, perm.} = 3.70 \text{ kNm}$$

Linear interaction can be used for cross-section verification.

Permitted load capacity

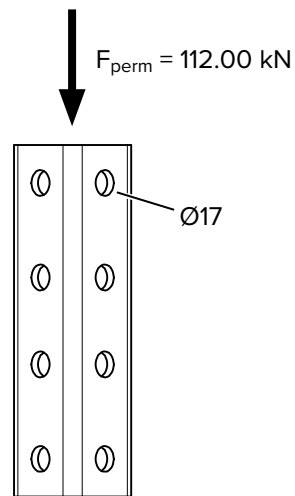

7.9 IK Waler Connector M (code:608430)

Stress resultant limits

$N_{pl, perm.} = 974.00 \text{ kN}$

$V_{pl, z, perm.} = 696.00 \text{ kN}$

$M_{pl, y, perm.} = 82.39 \text{ kNm}$

Linear interaction can be used for cross-section verification.

Permitted load ratings of holes



Attach IK Spindles only at the angles shown here!

Always use 12no. IK Pins Ø20 to secure an IK Waler Connector M.

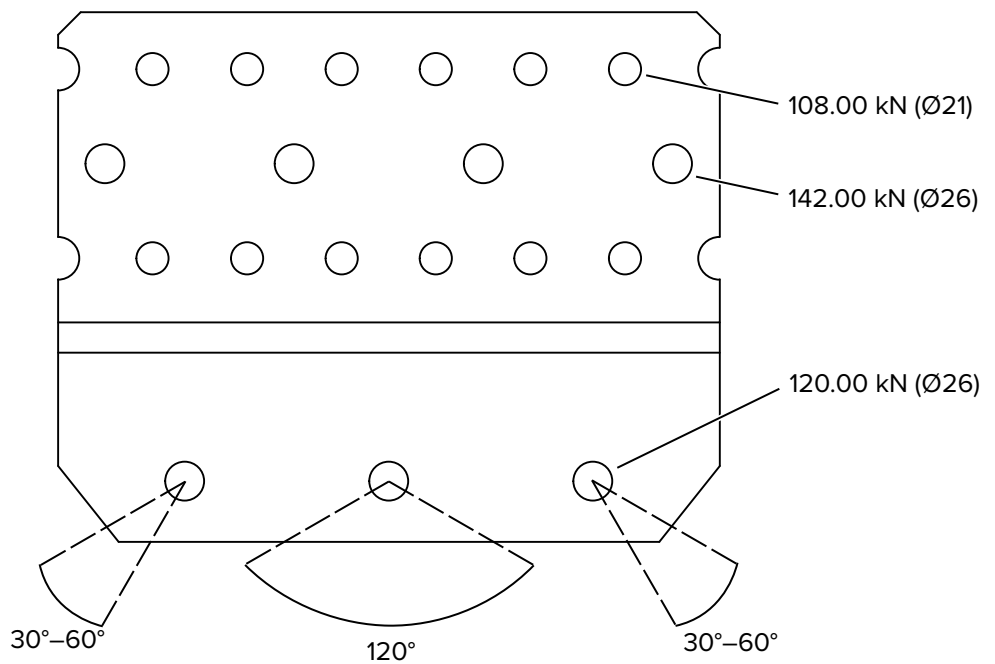

7.10 IK Adapter Waler Connector M (code:608440)

Stress resultant limits

$$N_{pl, perm.} = 805.00 \text{ kN}$$

$$V_{pl, z, perm.} = 556.00 \text{ kN}$$

$$M_{pl, y, perm.} = 45.87 \text{ kNm}$$

Linear interaction can be used for cross-section verification.

Permitted load ratings of holes



Attach IK Spindles only at the angles shown here!

Always use 4no. IK Pins $\varnothing 20$ and 2no. IK Pins $\varnothing 25$ to secure an IK Adapter Waler Connector M.

When IK Waler Connectors M and IK Adapters Waler Connector M are used together, do not exceed the permitted bolt forces when attaching Waler L!

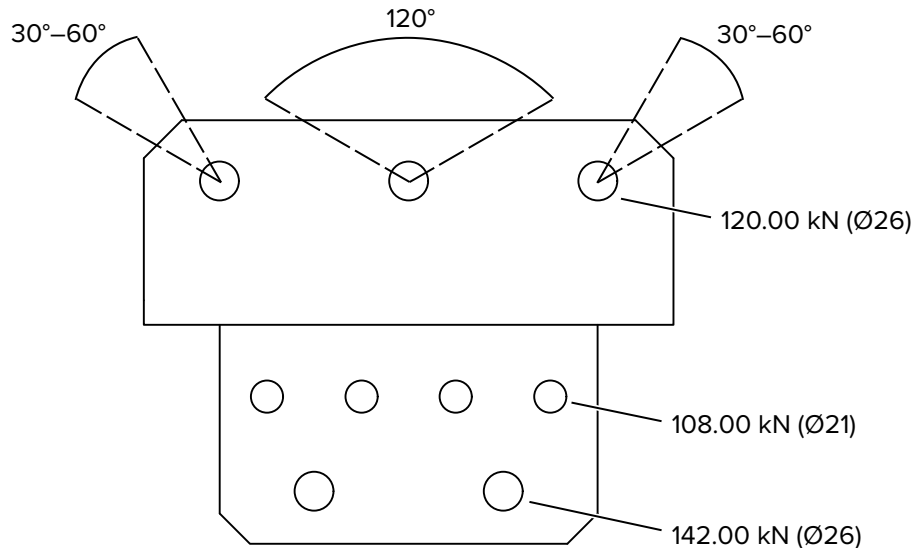

7.11 IK Waler Connector Flex M (code:608485)

Stress resultant limits

$$N_{pl, perm.} = 602.00 \text{ kN}$$

$$V_{pl, z, perm.} = 396.00 \text{ kN}$$

$$M_{pl, y, perm.} = 37.72 \text{ kNm}$$

Linear interaction can be used for cross-section verification.

Permitted load ratings of holes



Always use 6no. IK Pins $\varnothing 20$ to secure an IK Waler Connector Flex M to the IK Waler M!

The maximum permitted bending moment M_{perm} when using 6no. IK Pins $\varnothing 20$ is 37.72 kNm!

Check if pin can withstand the imposed loads!

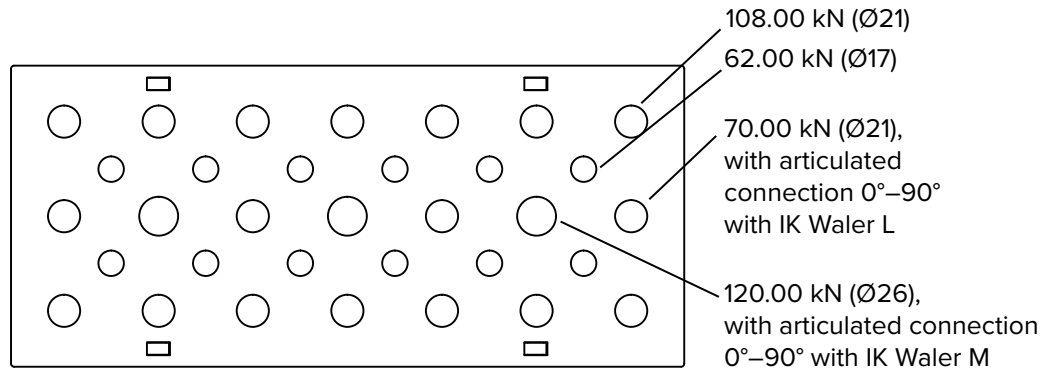

7.12 IK Cross Connector M (code:608470)

Stress resultant limits

$N_{pl, perm.} = 562.00 \text{ kN}$

$V_{pl, z, perm.} = 316.00 \text{ kN}$

$M_{pl, y, perm.} = 23.74 \text{ kNm}$

Linear interaction can be used for cross-section verification.

Permitted load ratings of holes when connecting 1no. IK Spindle

Attach IK Spindles only at the angles shown here!
 Always use 4no. Bolts M24 × 130 (code:608475) to secure the IK Cross Connector M!

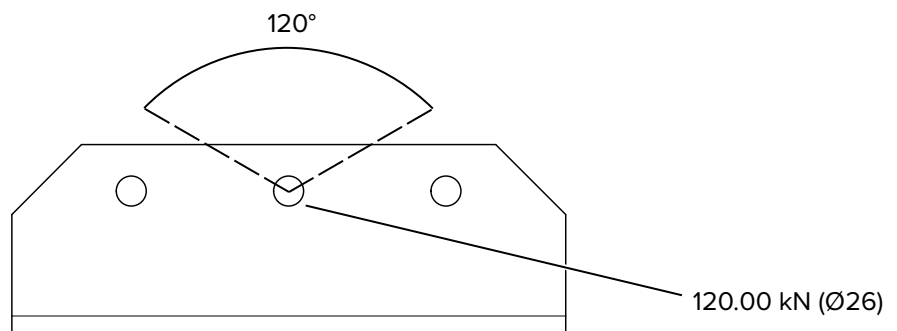
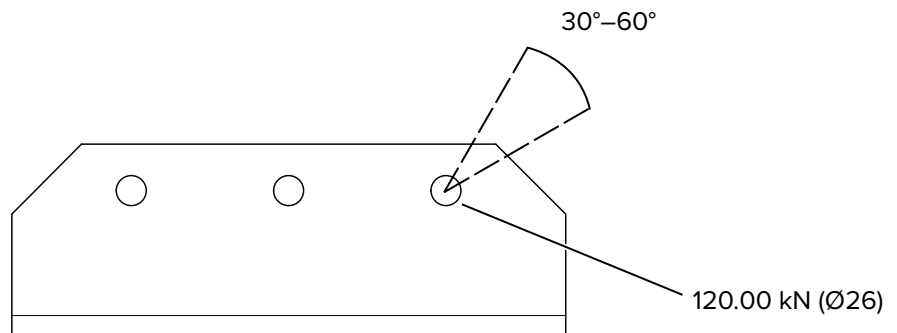

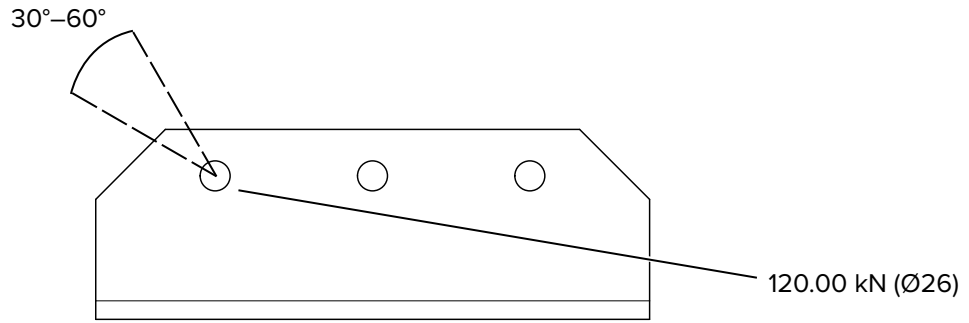

Permitted load ratings of holes when connecting 3no. IK Spindles



Attach IK Spindles only at the angles shown here!

Always use 4no. Bolts M24 × 130 (code:608475) to secure the IK Cross Connector M!

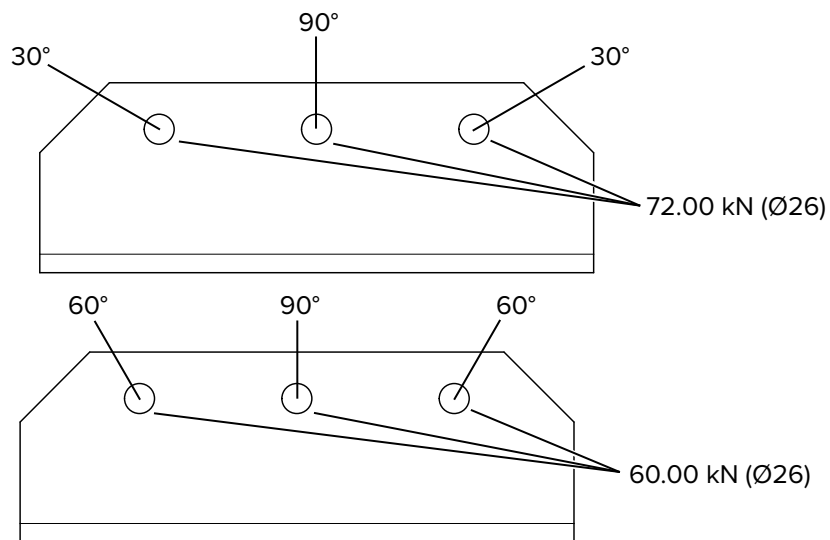

Linear interpolation can be applied to determine the load rating for angles between 30° and 60°.

7.13 IK Adjustable Connector

Permitted load ratings of holes

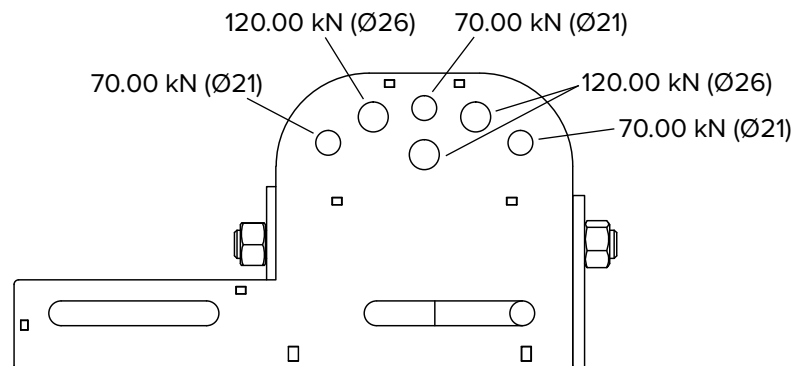

7.14 IK Jack (code:608775)

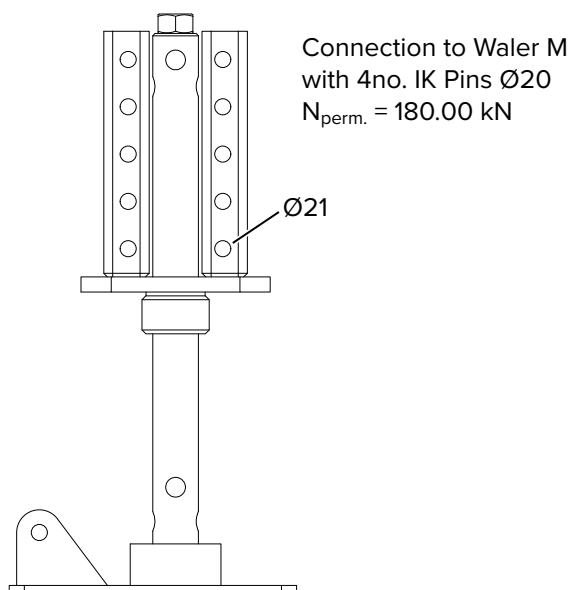

7.15 IK Adapter M/L (code:608770)

Stress resultant limits

$N_{pl, perm.} = 150.00 \text{ kN}$

$V_{pl, z, perm.} = 50.00 \text{ kN}$

$M_{pl, y, perm.} = 3.32 \text{ kNm}$

Linear interaction can be used for cross-section verification.

Permitted load rating depending on configuration

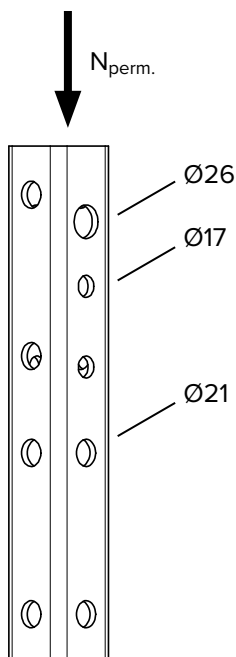

Connecting Waler M to Waler M, parallel or crosswise
(Refer to page 66 and page 67)
 $N_{perm.} 136.00 \text{ kN}$

Connecting Waler M to Waler L, parallel or crosswise
(Refer to page 68 and page 69)
 $N_{perm.} 112.00 \text{ kN}$

Connecting Waler L to Waler L using Waler Connector L
(Refer to page 78)
 $N_{perm.} 74.00 \text{ kN}$

Connecting Waler L to Waler M using Waler Connector M
(Refer to page 80)
 $N_{perm.} 77.00 \text{ kN}$



Verification of cross-section for all three possible stress resultants (N, V, M) with linear interaction required!

7.16 IK Wheel Connector (code:608600)

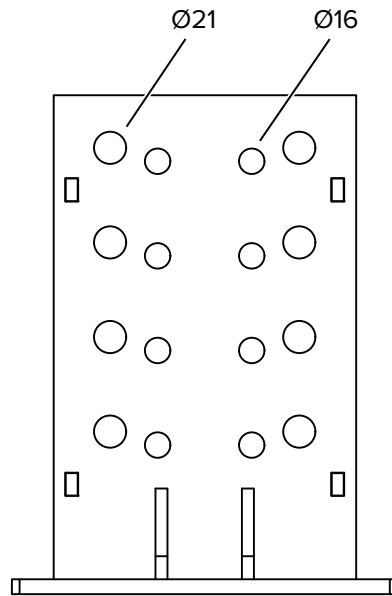

Wheel load for connection with IK Waler L and 4no. IK Pins Ø16
30.00 kN

Wheel load for connection with IK Waler M and 4no. IK Pins Ø20
60.00 kN

7.17 Information on using bolts of class 8.8

All SWLs indicated in Section 7 apply to the use of IK Pins or bolts of class 10.9.

Bolts of class 8.8 can be used as an alternative. However, the SWL of the connections is lower in this case.

The table below shows the SWLs of bolts of class 8.8 used in conjunction with INFRA-KIT.



If in Section 7 a lower SWL for a connection than the SWL for the Bolt 8.8 is stated, the lower SWL always applies!

	M16 on IK Waler L [kN]	M20 on IK Waler L [kN]	M20 on IK Waler M [kN]	M24 on IK Waler M [kN]
Bolt 8.8 F_{perm} [kN]	45.70	84.42	79.49	131.36

8 Connecting IK Walers L and M

Various connectors are available for connecting walers. Always use the proper IK Pins to attach the connectors. Use IK Pins Ø16 or IK Pins Ø20 to connect Walers L and IK Pins Ø20 or IK Pins Ø25 to connect Walers M.



Screws 10.9 of the respective diameter can be used as an alternative for every connection! This does not change the SWL of the connections.



The positions of some of the Waler Bolts have to be changed for some of the Waler connections. This includes the bolts used to join the two U-profiles of the Walers to one another. The Waler Bolts can easily be removed and then inserted at the next possible position.

8.1 Changing position of Waler Bolts

The positions of some of the Waler Bolts in some of the waler connections shown in this section have to be changed. We recommend not putting the Waler Bolts back into place until the walers have been connected.

There is a Spacer Sleeve IK Waler on each Waler Bolt between the U-profiles. The Spacer Sleeve IK Waler keeps the U-profiles spaced as specified. The Spacer Sleeve IK Waler must be reinstalled when inserting the bolts again.

NOTE

Spacer Sleeves fall off!

When the Waler Bolts are extracted from the walers, the Spacer Sleeve may fall off of the Waler Bolt. Work carefully to avoid losing the Spacer Sleeve!

NOTE

Do not exceed the maximum allowed spacing of the Waler Bolts!

The Waler Bolts should be ≤ 500 mm away from the end of the Waler (max. 7 holes in between)!

The Waler Bolts should be spaced ≤ 500 mm apart (max. 7 holes in between)!

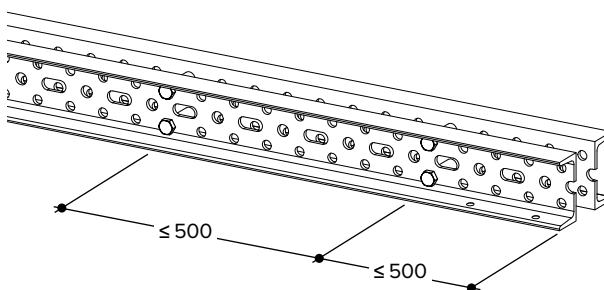

Waler Bolts should be fastened to the 5th hole from the waler's end to avoid problems when attaching connectors or adaptors.

Step 1 Release and remove the nuts from the Waler Bolts.

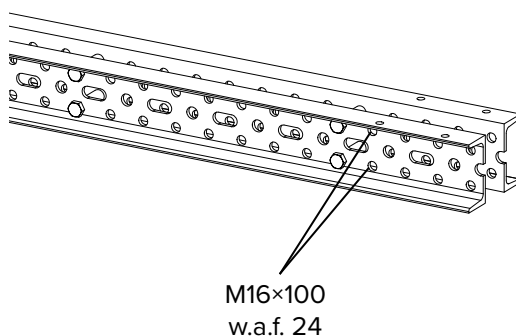

Step 2 Extract the Waler Bolts from the waler. Catch the Spacer Sleeves.

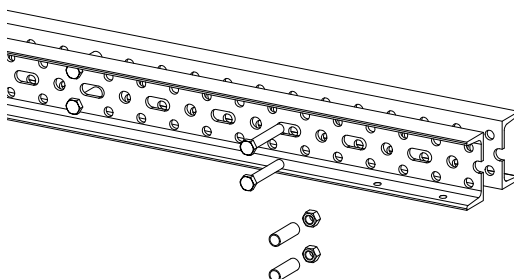

Step 3 Guide the Waler Bolts through the nearest possible hole in the U-profile.

Step 4 Slide the Spacer Sleeve onto the Waler Bolt.

Connecting IK Walers L and M

Step 5 Guide the Waler Bolt through the other U-profile and secure with the nut. The required torque for tightening the nuts is shown below.

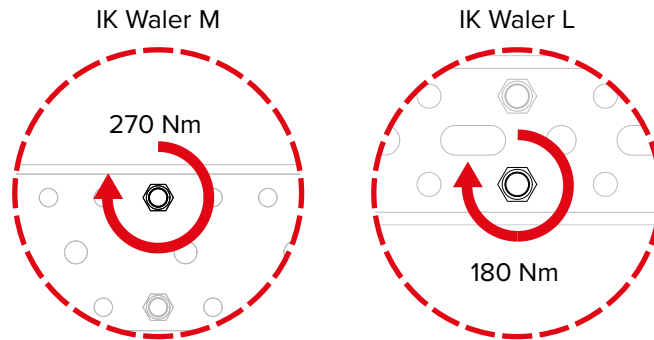

8.2 End-to-end connection of IK Walers

End-to-end connections can be done using various various components. The number and possible orientation of the connections vary depending on which spindles or walers are used. For information on how to connect Spindles, refer to page 89. For information on how to connect Walers, refer to page 76.

The following end-to-end connections are possible:

- With no connection points for spindles and walers
- With connection points to one side (flange)
- With connection points to both sides (flange)
- With connection points to one or both sides (web)

8.2.1 Connecting 2no. Walers L – without spindle connectors (with IK Waler Connector Flex L)

Components needed:

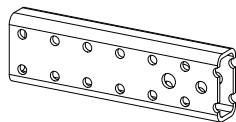

1no. IK Waler Connector Flex L
(code:608490)

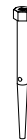

12no. IK Pins Ø16
(code:608816)



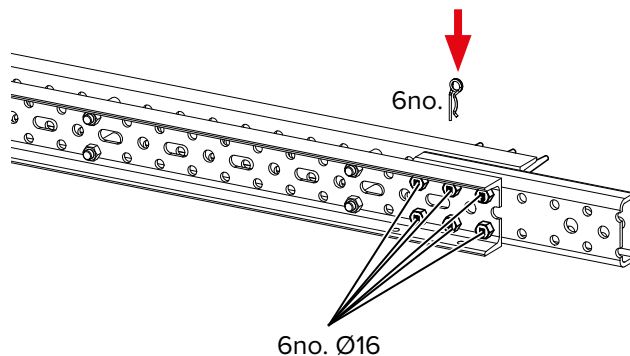

12no. Spring Cotter Pins 4
(code:173776)

Step 1 Insert the IK Waler Connector Flex L into the first Waler L and fasten with 6no. IK Pins Ø16. Secure the IK Pins with the Spring Cotter Pins.

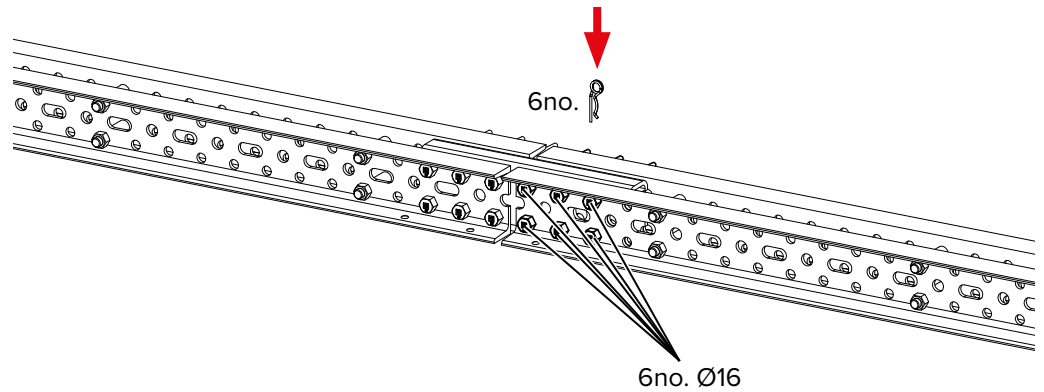

Step 2 Slide the second waler over the IK Waler Connector Flex L and fasten with 6no. IK Pins Ø16. Secure the IK Pins with the Spring Cotter Pins.



 The bending moment capacity of this connection is 15.72 kNm!
Use the interaction equation to check if the pin connections can withstand the loads!

8.2.2 Connecting 2no. Walers L – without spindle connectors (with IK Waler Connector L 25)

Components needed:

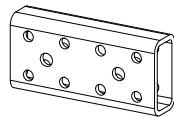

1no. IK Waler Connector L 25
(code:608445)

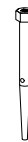

8no. IK Pins Ø16
(code:608816)



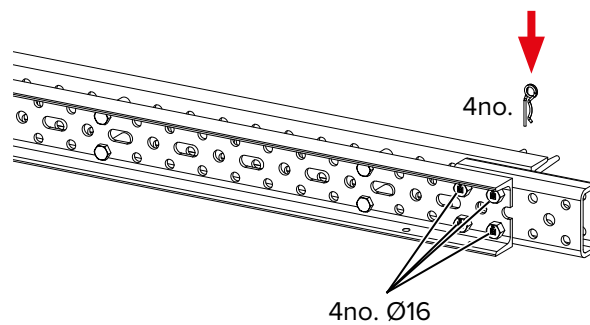

8no. Spring Cotter Pins 4
(code:173776)

Step 1 Insert the IK Waler Connector L 25 into the first Waler L and fasten with 4no. IK Pins Ø16. Secure the IK Pins with the Spring Cotter Pins.

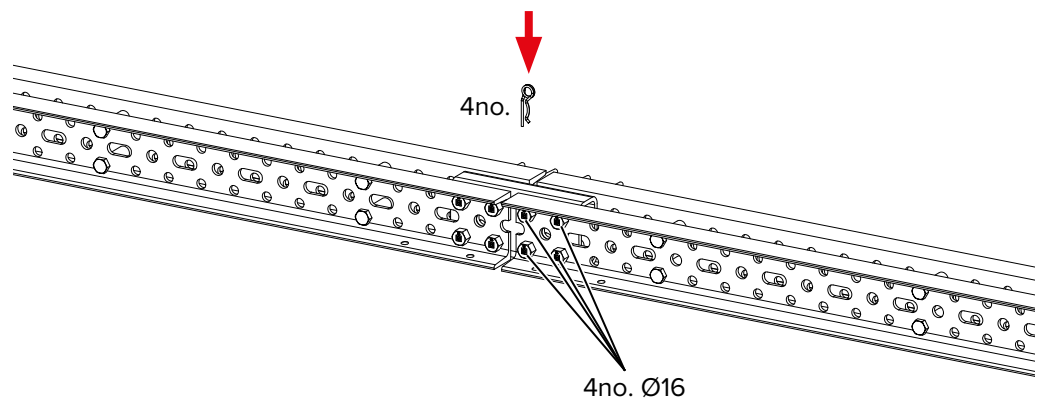

Step 2 Slide the second Waler over the IK Waler Connector L 25 and fasten with 4no. IK Pins Ø16. Secure the IK Pins with the Spring Cotter Pins.



 The bending moment capacity of this connection is 10.90 kNm!
Use the interaction equation to check if the pin connections can withstand the loads!

Connecting IK Walers L and M

8.2.3 Connecting 2no. Walers L – with spindle connectors on one flange side

Components needed:

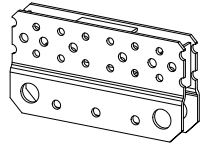

1no. IK Waler Connector L
(code:608420)



12no. IK Pins Ø16
(code:608816)



12no. Spring Cotter Pins 4
(code:173776)

Step 1 Insert the IK Waler Connector L into the first Waler L and fasten with 6no. IK Pins Ø16. Secure the IK Pins with the Spring Cotter Pins.

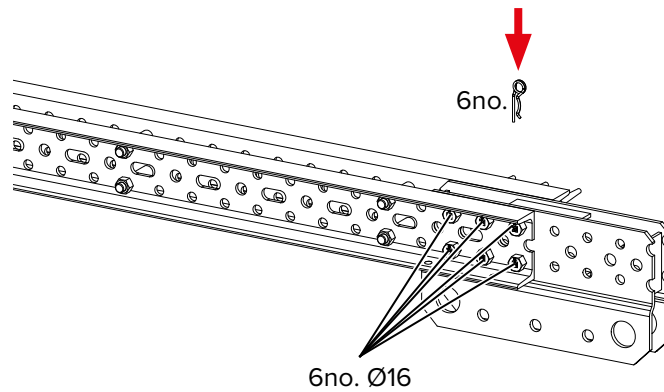

Step 2 Slide the second Waler L onto the IK Waler Connector L and fasten with 6no. IK Pins Ø16. Secure the IK Pins with the Spring Cotter Pins.

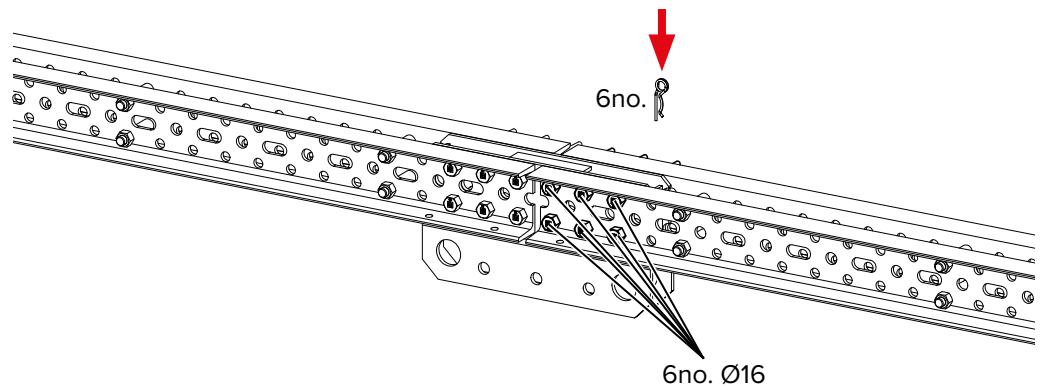

8.2.4 Connecting 2no. Walers L – with spindle connectors on both flange sides

Components needed:

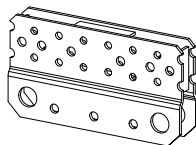

1no. IK Waler Connector L
(code:608420)

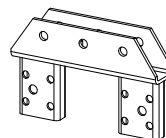

1no. IK Adapter
Waler Connector L
(code:608460)



12no. IK Pins Ø16
(code:608816)



12no. Spring Cotter Pins 4
(code:173776)

Step 1 Insert the IK Waler Connector L into the first Waler L and fasten with 2no. IK Pins Ø16. Secure the IK Pins with the Spring Cotter Pins.

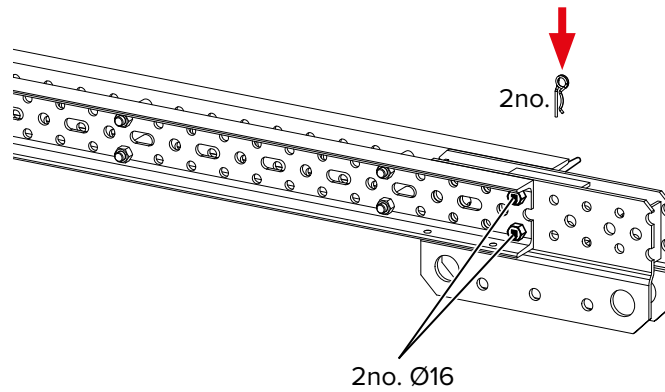

Step 2 Slide the second Waler L onto the IK Waler Connector L and fasten with 2no. IK Pins Ø16. Secure the IK Pins with the Spring Cotter Pins.

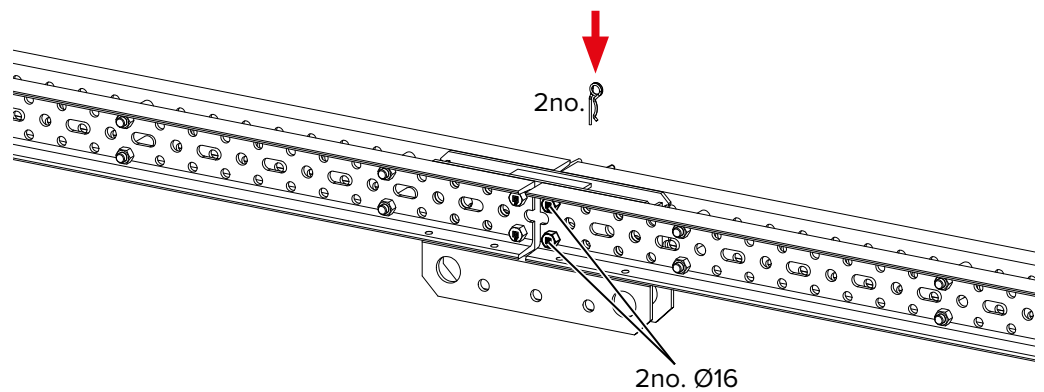

Step 3 Insert the IK Adapter Waler Connector L into the IK Waler Connector L.

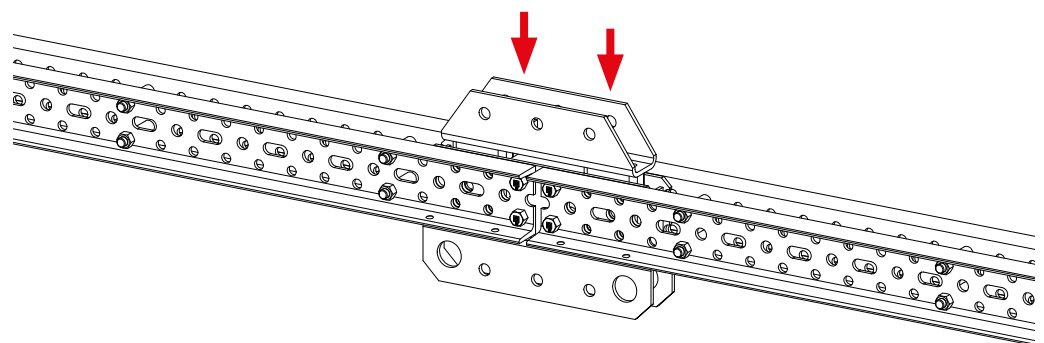

Connecting IK Walers L and M

Step 4 Fasten all of the components with the remaining 8no. IK Pins Ø16. Secure the IK Pins with the Spring Cotter Pins.

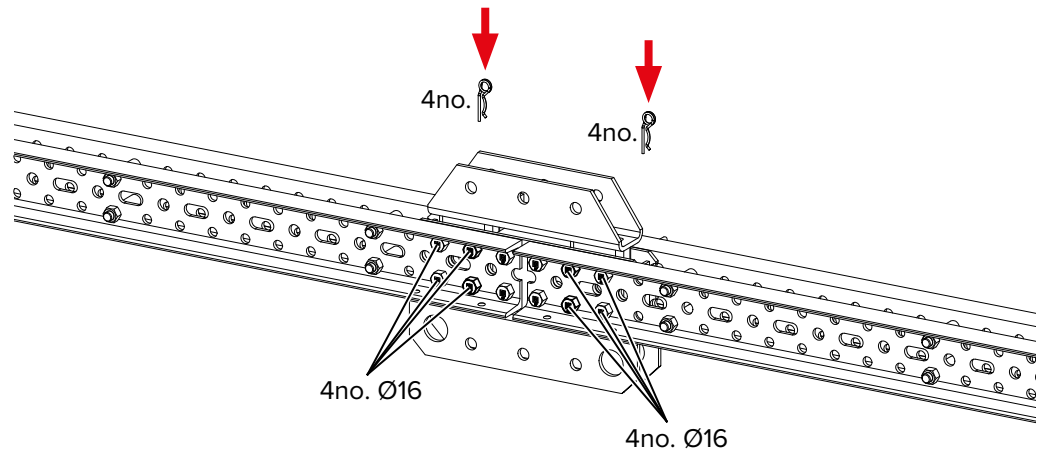

8.2.5 Connecting 2no. Walers L – with spindle connectors on one or both web sides

This connection can be done using the IK Cross Connector L (code:608420) on its own or in conjunction with the IK Waler Connector L (code:608460). Optionally, just the IK Waler Connector Adapter L can be used instead.



WARNING

Connection can fail!

When IK Pins are used to attach an IK Cross Connector to the IK Waler, the IK Cross Connector cannot absorb tensile loads!

This can cause failure and components can fall off!

This can cause personal injury or death!

Always use bolts to attach an IK Cross Connector to the IK waler!

NOTE

Comply with the lowest Safe Working Load!

This connection is created using only the 4no. Hexagon Bolts M20 x 130 with Nuts in the centre row of holes in the walers. Therefore the safe working load of the waler connection is lower than that of the standard connection with 12no. IK Pins Ø16.

Components needed:

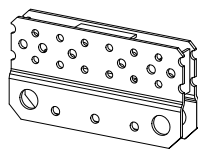

1no. IK Waler Connector L
(code:608420)

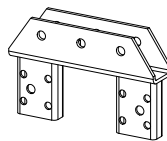

1no. IK Adapter Waler Connector L
(code:608460)

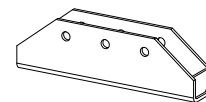

1no. or 2no. IK Cross Connector L
(code:608450)



4no. Hexagon Bolts M20 x 130 with Nuts
(code:608456)

Step 1 Slide the IK Waler Connector L into the first Waler L.

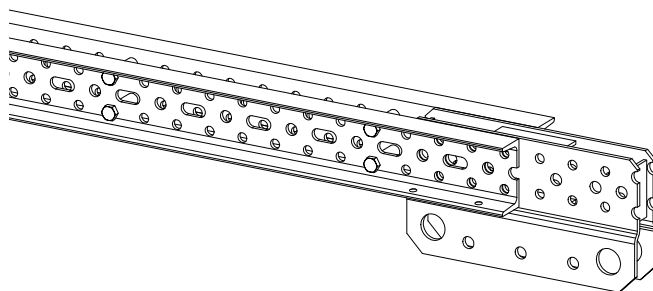

Step 2 Slide the IK Adapter Waler Connector into the IK Waler Connector L.

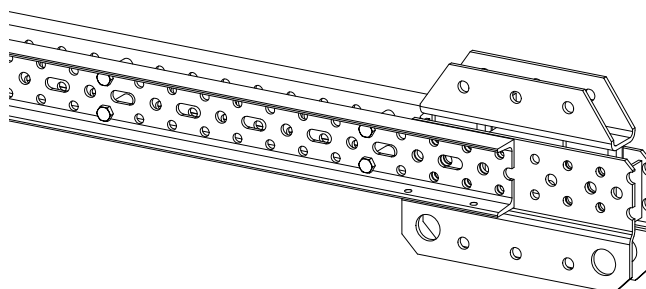

Step 3 Press 1no. or 2no. IK Cross Connectors L against the web sides of the first Waler L and attach using 2no. Bolts M20 x 120 with Nut. Do not tighten the bolts.

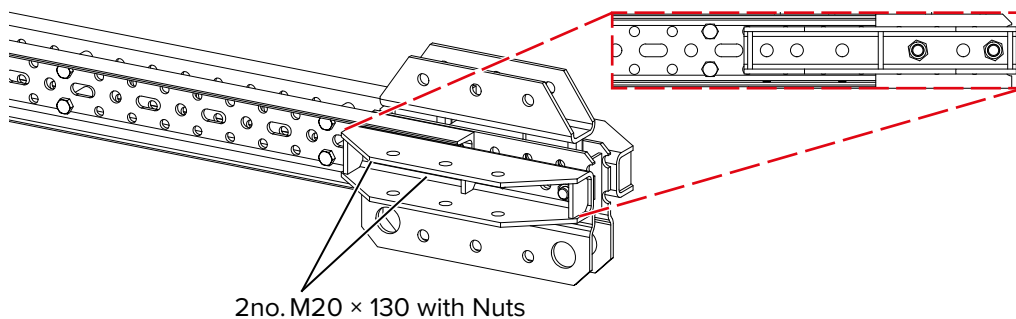

Step 4 Slide the second Waler L onto the IK Waler Connector L and fasten with 2no. Bolts M20 x 120 with Nuts. Tighten all four bolts.

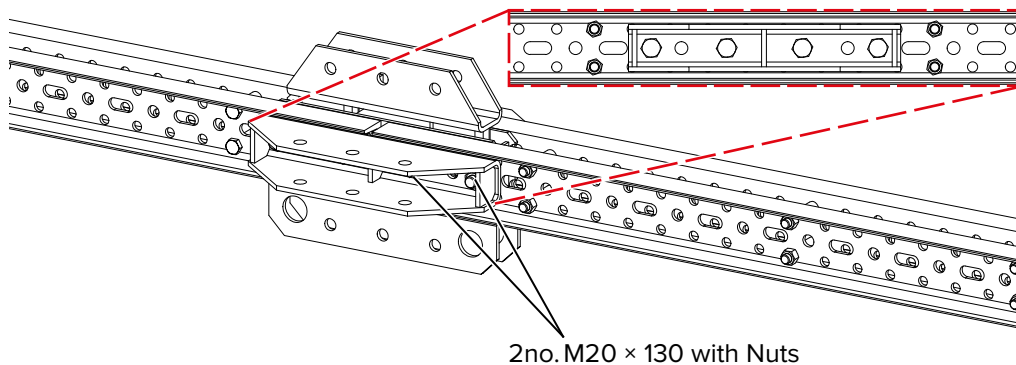

Connecting IK Walers L and M



The bending moment capacity of this connection is 9.63 kNm!

Use the interaction equation to check if the pin connections can withstand the loads!

Check if the connection of the IK Cross Connectors L (code:608450) with the bolts can withstand the imposed axial (N) loads.

8.2.6 Connecting 2no. Walers M – without spindle connectors

Components needed:

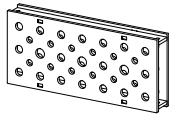

1no. IK Waler Connector Flex M
(code:608485)



12no. IK Pins Ø20
(code:608820)



12no. Spring Cotter Pins 4
(code:173776)

Step 1 Insert the IK Waler Connector Flex M into the first Waler M and fasten with 6no. IK Pins Ø20. Secure the IK Pins with the Spring Cotter Pins.

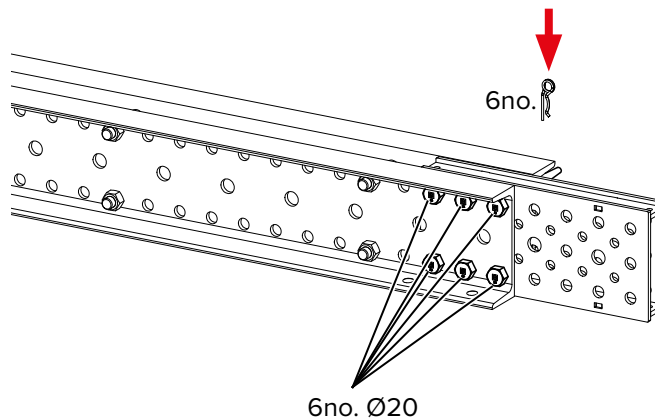

Step 2 Slide the second Waler over the IK Waler Connector Flex M and fasten with 6no. IK Pins Ø20. Secure the IK Pins with the Spring Cotter Pins.

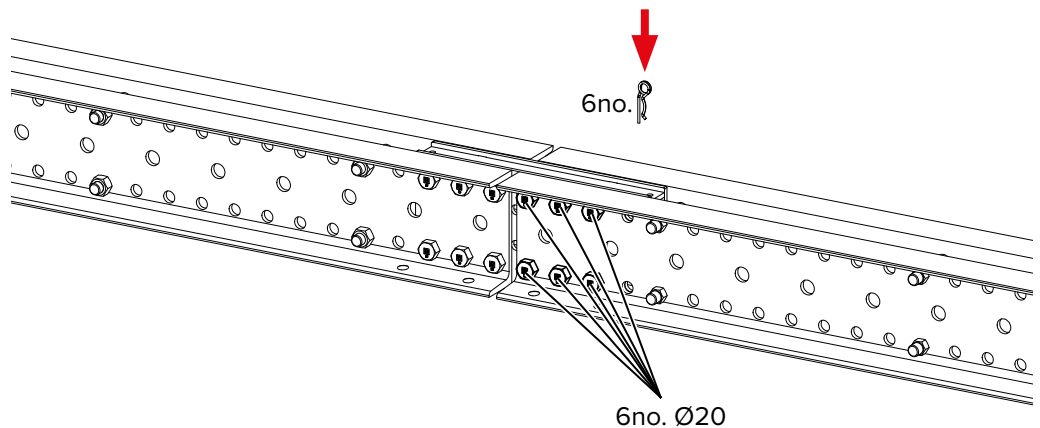

The bending moment capacity of this connection is 37.72 kNm!

Use the interaction equation to check if the pin connections can withstand the loads!

8.2.7 Connecting 2no. Walers M – with spindle connectors on one flange side

Components needed:

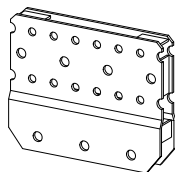

1no. IK Waler Connector M
(code:608430)

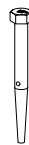

12no. IK Pins Ø20
(code:608820)



12no. Spring Cotter Pins 4
(code:173776)

Step 1 Insert the IK Waler Connector M into the first Waler M and fasten with 6no. IK Pins Ø20. Secure the IK Pins with the Spring Cotter Pins.

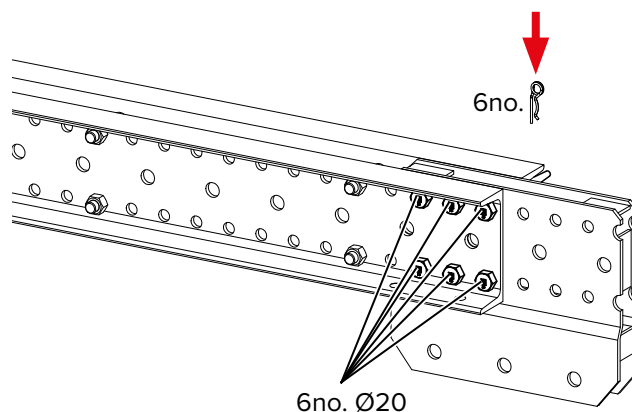

Step 2 Slide the second Waler M onto the IK Waler Connector M and fasten with 6no. IK Pins Ø20. Secure the IK Pins with the Spring Cotter Pins.

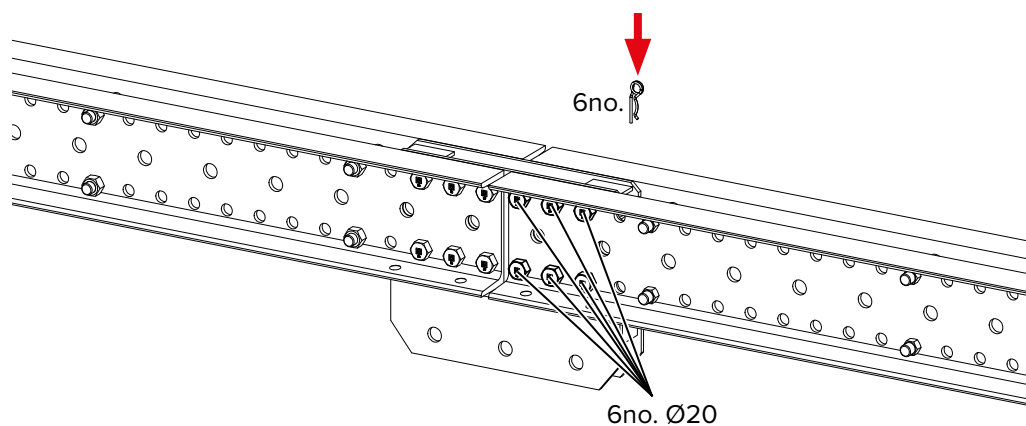

Connecting IK Walers L and M

8.2.8 Connecting 2no. Walers M – with spindle connectors on two flange sides

Components needed:

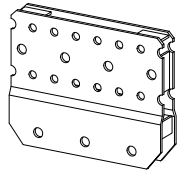

1no. IK Waler Connector M
(code:608430)

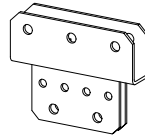

1no. IK Adapter
Waler Connector M
(code:608440)

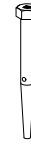

12no. IK Pins Ø20
(code:608820)



12no. Spring Cotter Pins 4
(code:173776)



2no. IK Pins Ø25
(code:608825)



2no. Spring Cotter Pins 5
(code:174553)

Step 1 Insert the IK Waler Connector M into the first Waler M and fasten with 4no. IK Pins Ø20. Secure the IK Pins with the Spring Cotter Pins.

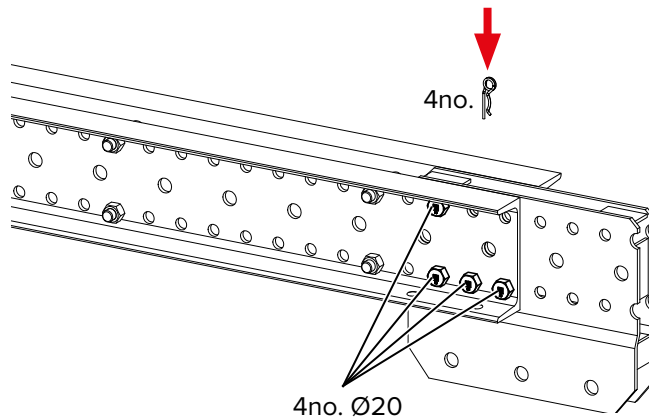

Step 2 Slide the second Waler M onto the IK Waler Connector M and fasten with 4no. IK Pins Ø20. Secure the IK Pins with the Spring Cotter Pins.

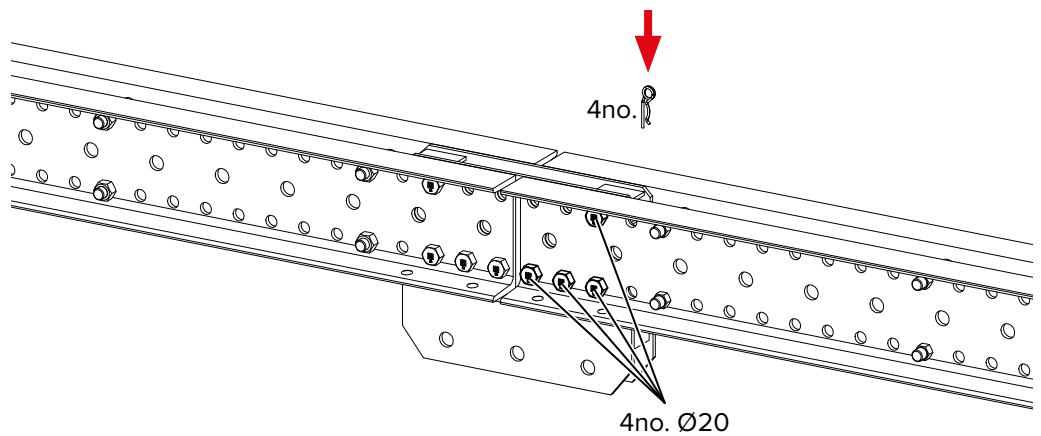

Step 3 Insert the IK Adapter Waler Connector M into the IK Waler Connector M.

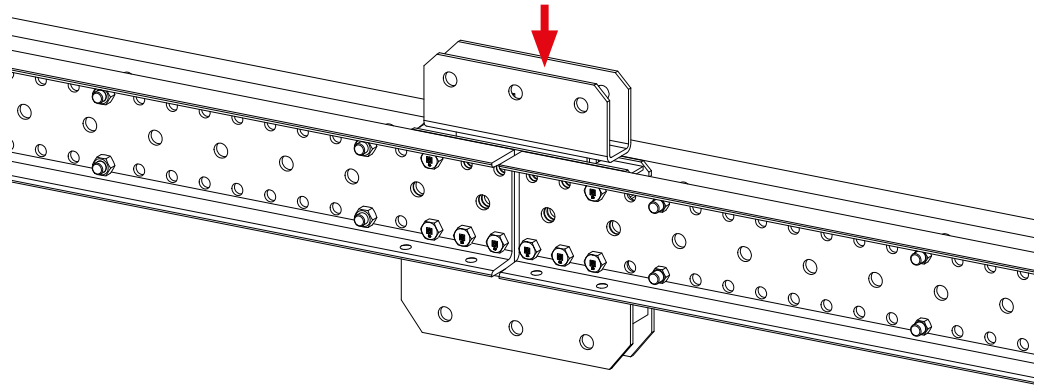

Step 4 Use the remaining 4no. IK Pins Ø20 and 2no. IK Pins Ø25 to secure all of the components. Secure the IK Pins with the Spring Cotter Pins.

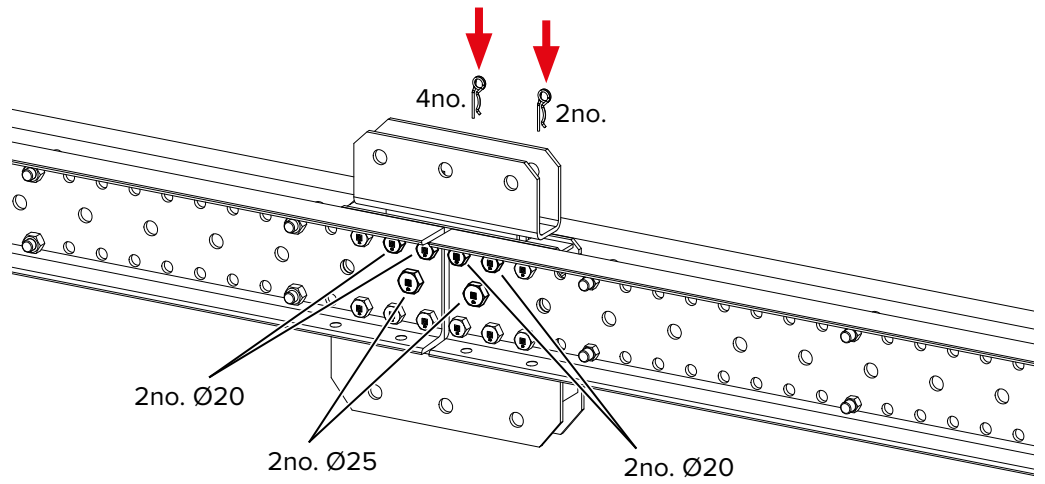

Connecting IK Walers L and M

8.2.9 Connecting 2no. Walers M – with spindle connectors on one or two web sides



WARNING

Connection can fail!

When IK Pins are used to attach an IK Cross Connector to the IK Waler, the IK Cross Connector cannot absorb tensile loads!

This can cause failure and components can fall off!

This can cause personal injury or death!

Always use bolts to attach an IK Cross Connector to the IK waler!

Components needed:

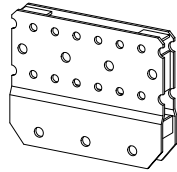

1no. IK Waler Connector M
(code:608430)

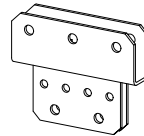

1no. IK Adapter
Waler Connector M
(code:608440)

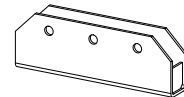

1no. or 2no.
IK Cross Connector M
(code:608470)



4no. Hexagon Bolts
M24 x 130 with Nuts
(code:608475)



12no. IK Pins Ø20
(code:608820)



12no. Spring Cotter Pins 4
(code:173776)

Step 1 Perform steps 1–4 of Section *Connecting 2no. Walers M – with spindle connectors on two flange sides* on page 56. Do not use IK Pins Ø25.

Step 2 Attach 1no. or 2no. IK Cross Connectors to the Walers using 4no. Bolts M24 x 130 with Nuts.

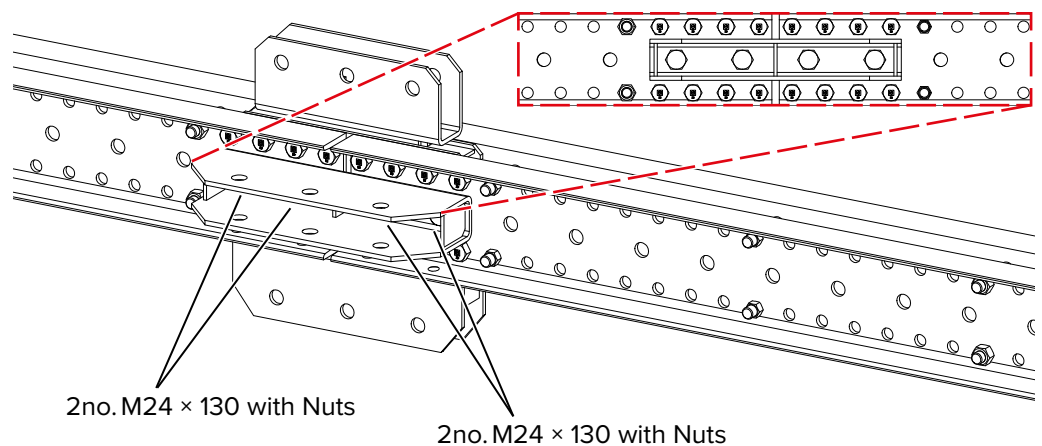

The bending moment capacity of this connection is 47.73 kNm!

Use the interaction equation to check if the pin connections can withstand the loads!

Take into consideration the axial force (N) from the IK Cross Connectors separately only for the bolt connection!

8.2.10 Connecting an IK Waler M to an IK Waler L

The Waler Connector Flex M can be used to connect an IK Waler M to an IK Waler L.

Components needed:

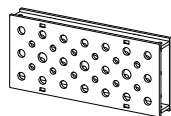

1no. IK Waler Connector Flex M
(code:608485)



6no. IK Pins Ø20
(code:608820)

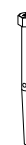

6no. IK Pins Ø16
(code:608816)



12no. Spring Cotter Pins 4
(code:173776)

Step 1 Insert the IK Waler Connector Flex into the IK Waler M and fasten with 6no. IK Pins Ø20. Secure the IK Pins with the Spring Cotter Pins.

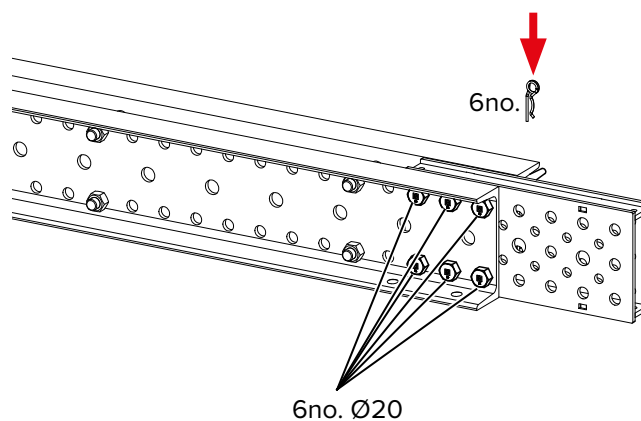

Step 2 Slide the IK Waler L onto the IK Waler Connector Flex M and fasten with 6no. IK Pins Ø16. Secure the IK Pins with the Spring Cotter Pins.

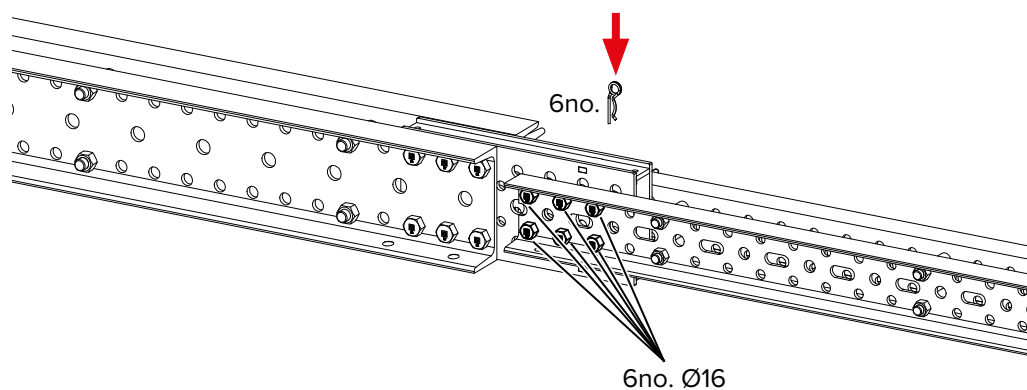

The bending moment capacity of this connection is 18.94 kNm!

Use the interaction equation to check if the pin connections can withstand the loads!

Connecting IK Walers L and M

8.3 Perpendicular rigid connection of walers

8.3.1 Perpendicular connection of IK Walers M

Components needed:

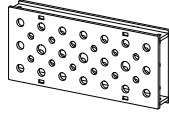

1no. IK Waler Connector Flex M
(code:608485)



10no. IK Pins Ø20
(code:608820)



10no. Spring Cotter Pins 4
(code:173776)

Step 1 Insert the IK Waler Connector Flex M into the first Waler M and fasten with 6no. IK Pins Ø20. Secure the IK Pins with the Spring Cotter Pins.

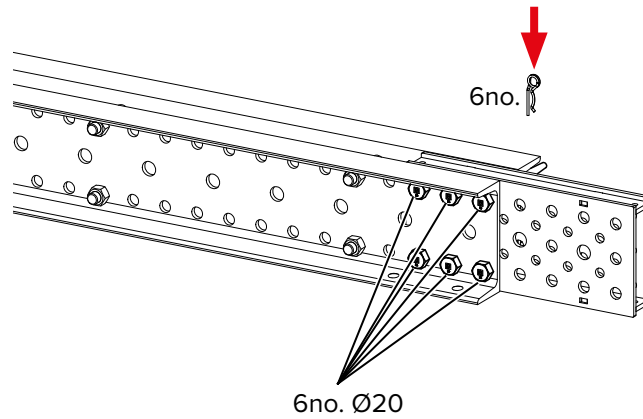

Step 2 Slide the second Waler M onto the IK Waler Connector Flex M at a right angle to the first IK Waler and fasten with 4no. IK Pins Ø20. Secure the IK Pins with the Spring Cotter Pins.

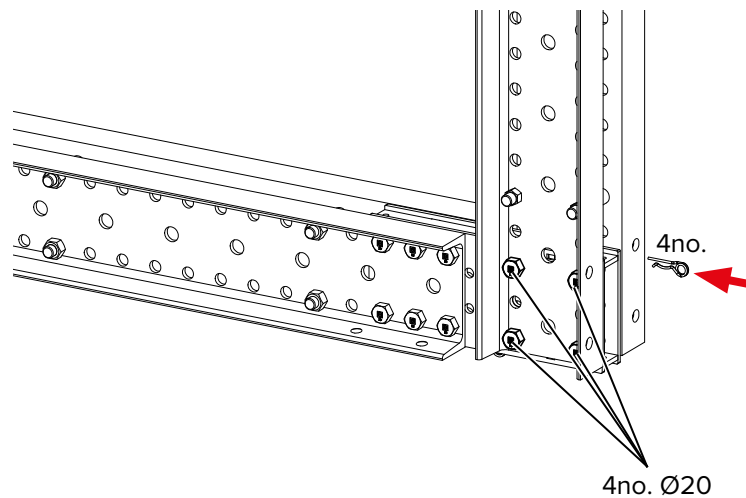

The bending moment capacity of this connection is 38.20 kNm!

Use the interaction equation to check if the pin connections can withstand the loads!

8.3.2 Perpendicular connection of IK Waler M to IK Waler L

Components needed:

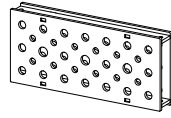

1no. IK Waler Connector Flex M
(code:608485)



6no. IK Pins Ø20
(code:608820)



4no. IK Pins Ø16
(code:608816)



10no. Spring Cotter Pins 4
(code:173776)

Step 1 Insert the IK Waler Connector Flex M into the first Waler M and fasten with 6no. IK Pins Ø20. Secure the IK Pins with the Spring Cotter Pins.

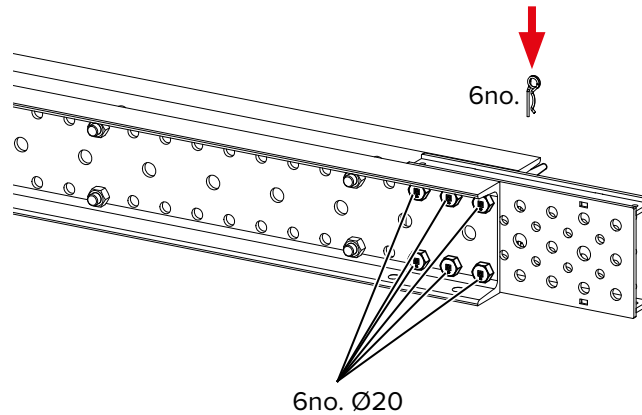

Step 2 Slide the Waler L onto the IK Waler Connector Flex M at a right angle and fasten with 4no. IK Pins Ø16. Secure the IK Pins with the Spring Cotter Pins.

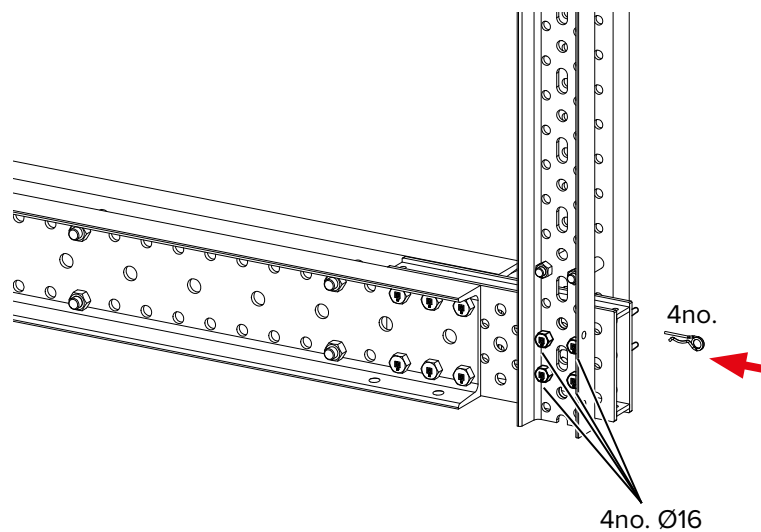

The bending moment capacity of this connection is 10.90 kNm!

Use the interaction equation to check if the pin connections can withstand the loads!

Connecting IK Walers L and M

8.3.3 Perpendicular connection of IK Walers L (with IK Waler Connector Flex L)

Components needed:

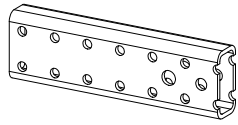

1no. IK Waler Connector Flex L
(code:608490)

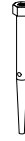

10no. IK Pins Ø16
(code:608816)



10no. Spring Cotter Pins 4
(code:173776)

Step 1 Insert the IK Waler Connector Flex L into the first Waler L and fasten with 6no. IK Pins Ø16. Secure the IK Pins with the Spring Cotter Pins.

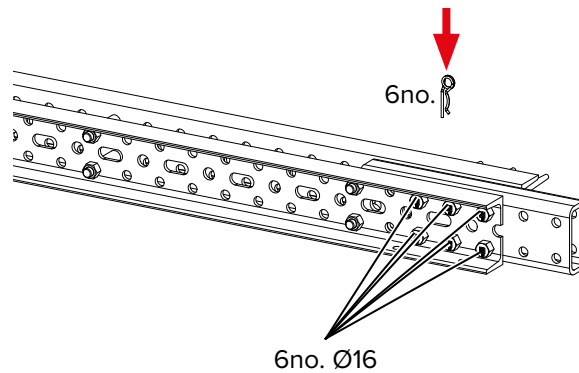

Step 2 Slide the Waler L onto the IK Waler Connector Flex L at a right angle and fasten with 4no. IK Pins Ø16. Secure the IK Pins with the Spring Cotter Pins.

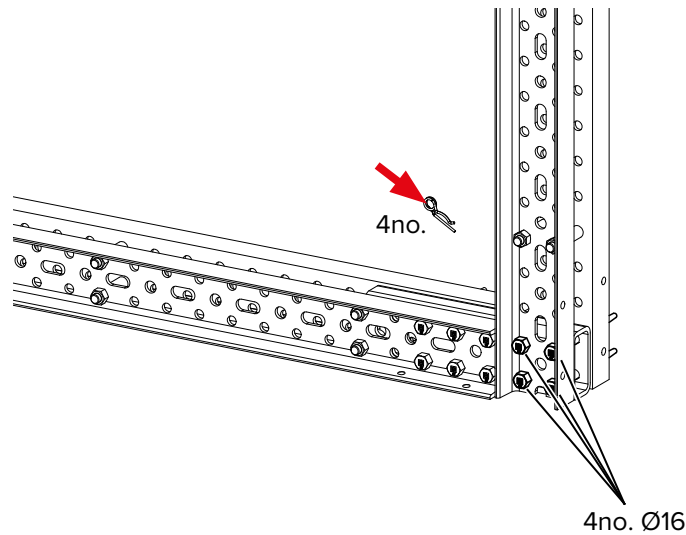

The bending moment capacity of this connection is 10.90 kNm!

Use the interaction equation to check if the pin connections can withstand the loads!

8.3.4 Perpendicular connection of IK Walers L (with IK Waler Connector L 25)

Components needed:

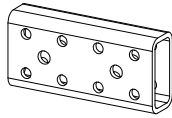

1no. IK Waler Connector L 25
(code:608445)

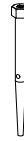

8no. IK Pins Ø16
(code:608816)



8no. Spring Cotter Pins 4
(code:173776)

Step 1 Insert the IK Waler Connector L 25 into the first Waler L and fasten with 4no. IK Pins Ø16. Secure the IK Pins with the Spring Cotter Pins.

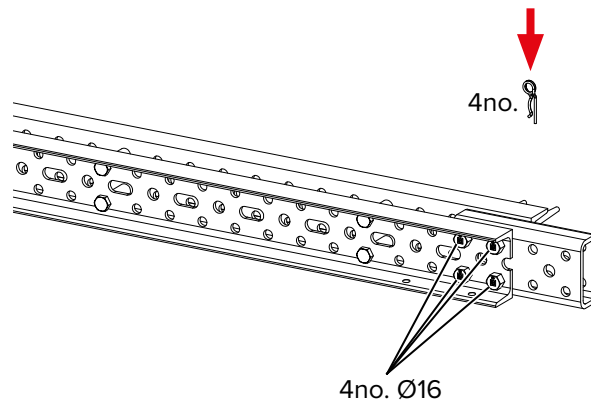

Step 2 Slide the Waler L onto the IK Waler Connector L 25 at a right angle and fasten with 4no. IK Pins Ø16. Secure the IK Pins with the Spring Cotter Pins.

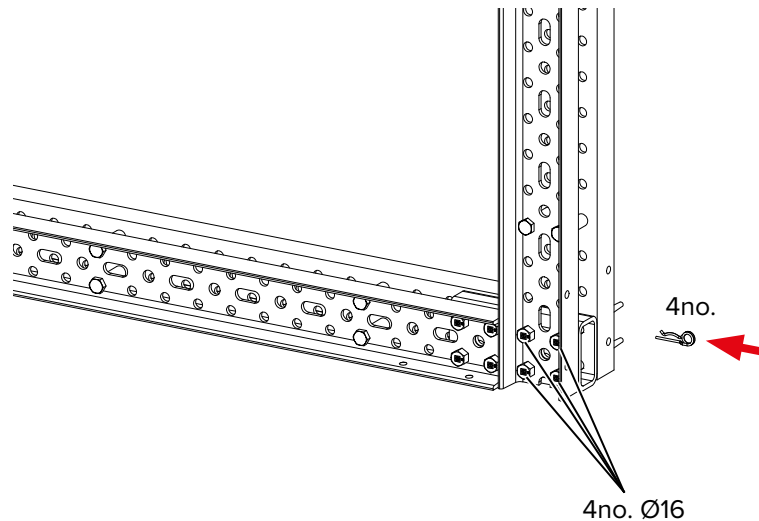

The bending moment capacity of this connection is 10.90 kNm!

Use the interaction equation to check if the pin connections can withstand the loads!

Connecting IK Walers L and M

8.4 Connecting Walers on top of one another

Two Walers L can be connected one on top of the other, parallel or crosswise using, the IK Adapter L.

The following Walers can be connected to one another using the IK Adapter M/L.

- 2no. Walers M on top of each another, parallel or crosswise
- 1no. Waler L on 1no. Waler M, parallel or crosswise

8.4.1 Connecting 2no. Walers

Components needed:

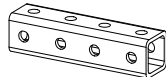

1no. IK Adapter L
(code:608480)



4no. IK Pins Ø16
(code:608816)



4no. Spring Cotter Pins 4
(code:173776)

Step 1 Insert the IK Adapter L into the first Waler L and fasten with 2no. IK Pins Ø16. Secure the IK Pins with the Spring Cotter Pins.

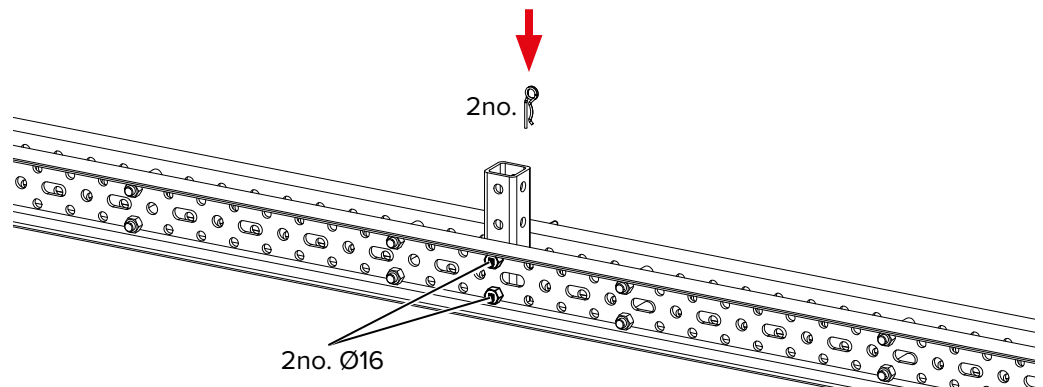

Step 2 Slide the second Waler L over the IK Adapter L, parallel or crosswise. Use 2no. IK Pins Ø16 to secure the IK Waler L. Secure the IK Pins with the Spring Cotter Pins.

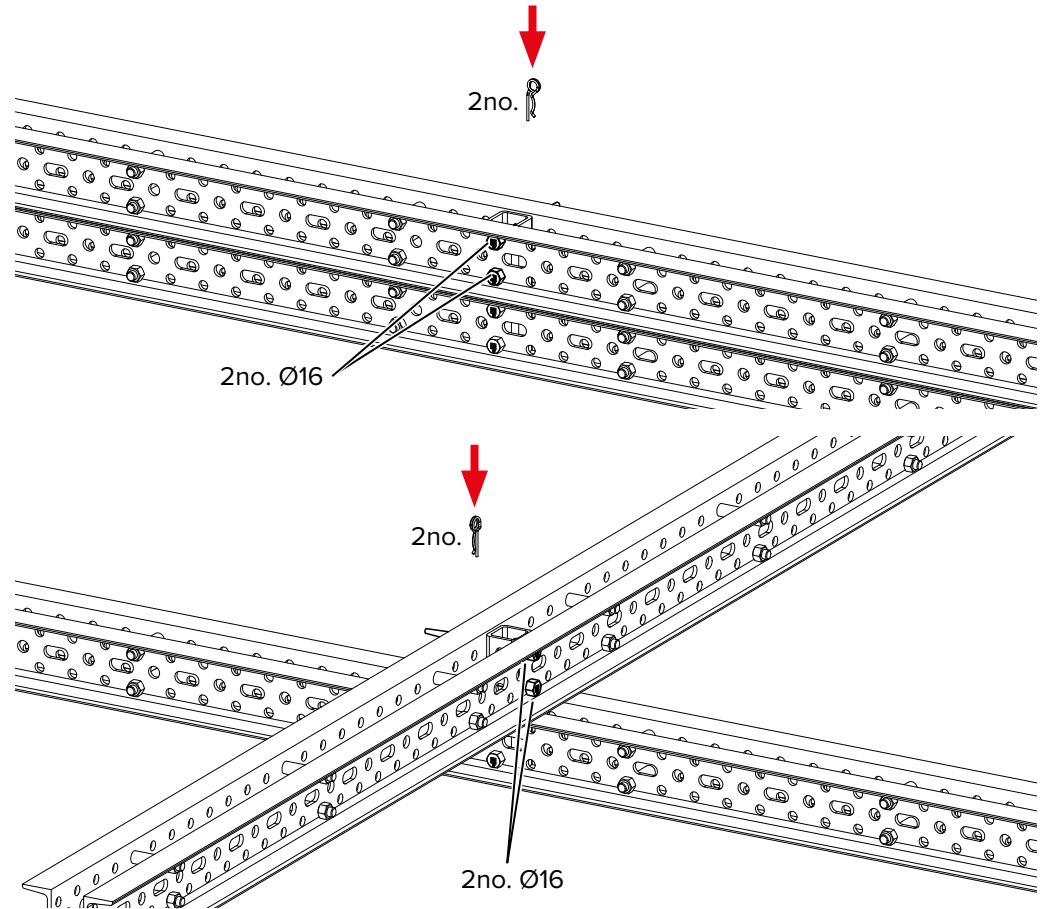

Connecting IK Walers L and M

8.4.2 Connecting 2no. Walers parallel to one another

Components needed:

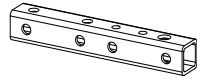

1no. IK Adapter M/L
(code:608770)



4no. IK Pins Ø20
(code:608820)



4no. Spring Cotter Pins 4
(code:173776)

Step 1 Insert the IK Adapter M/L into the first Waler M and fasten with 2no. IK Pins Ø20. Secure the IK Pins with the Spring Cotter Pins. Ensure that the IK Adapter M/L is positioned such that the holes Ø20 are perpendicular to the Waler M.

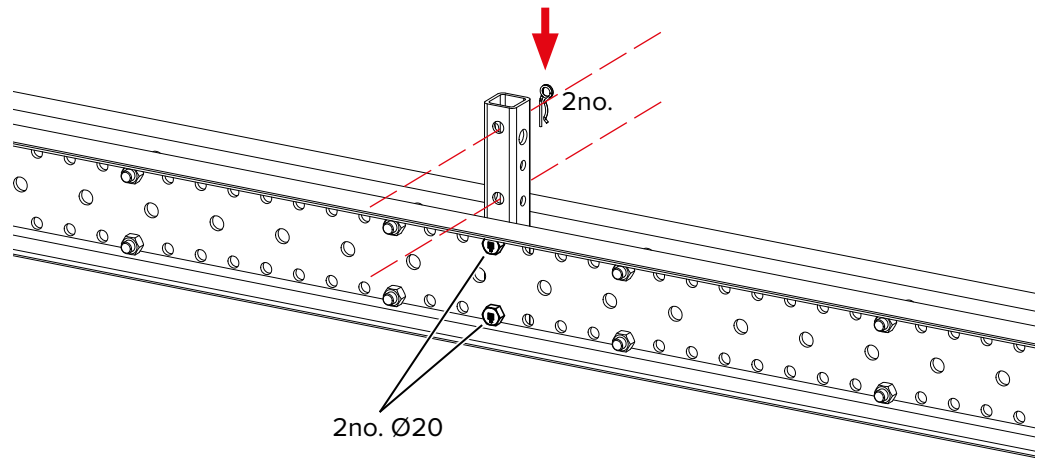

Step 2 Slide the second Waler M over the IK Adapter M, parallel to the first waler. Use 2no. IK Pins Ø20 to secure the IK Waler M. Secure the IK Pins with the Spring Cotter Pins.

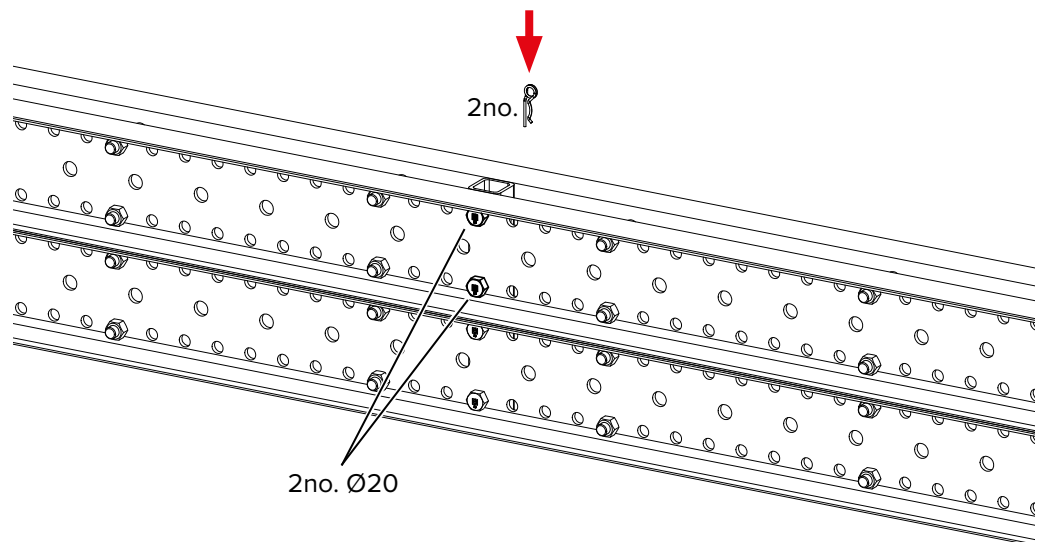

8.4.3 Connecting 2no. walers crosswise

Components needed:

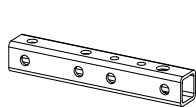

1no. IK Adapter M/L
(code:608770)

4no. IK Pins Ø20
(code:608820)

4no. Spring Cotter Pins 4
(code:173776)

Step 1 Insert the IK Adapter M/L into the first Waler M and fasten with 2no. IK Pins Ø20. Secure the IK Pins with the Spring Cotter Pins. Ensure that the IK Adapter M/L is positioned such that the holes Ø20 are parallel to the Waler M.

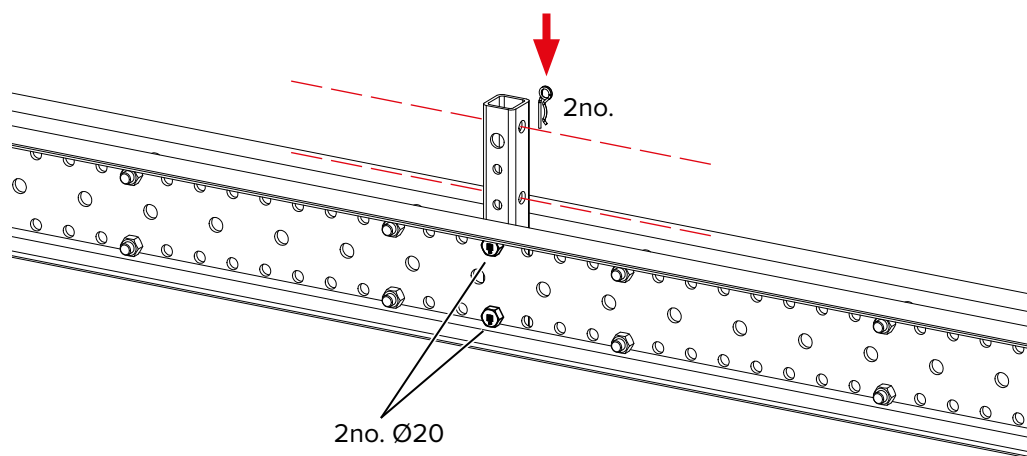

Step 2 Slide the second IK Waler M crosswise over the IK Adapter M/L. Use 2no. IK Pins Ø20 to secure the IK Waler M. Secure the IK Pins with the Spring Cotter Pins.

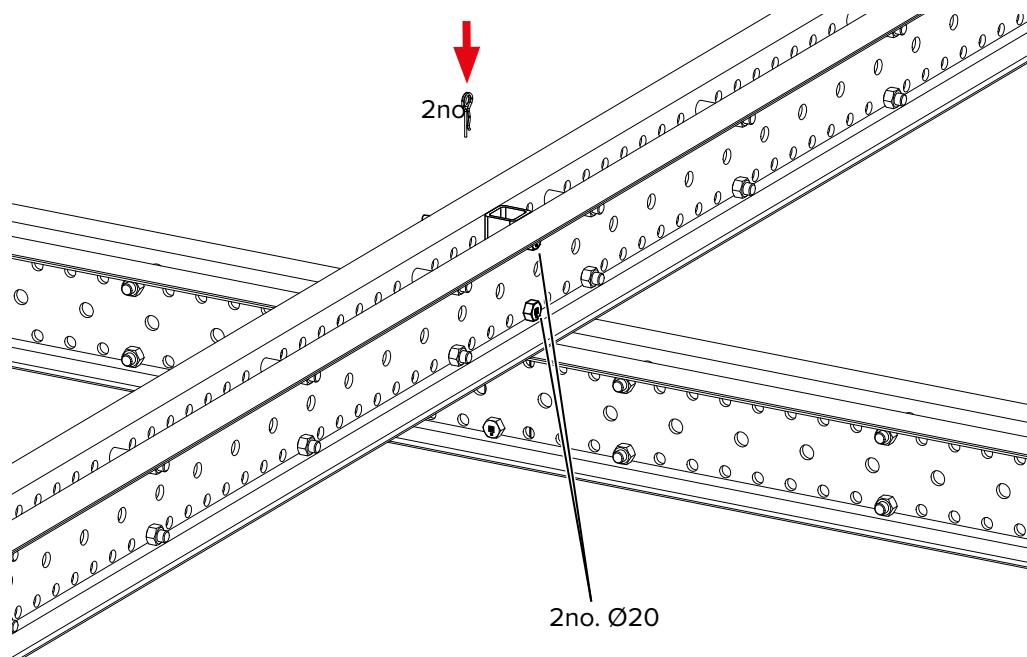

Connecting IK Walers L and M

8.4.4 Connecting Waler M to Waler L parallel to one another

Components needed:

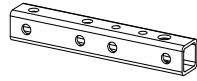

1no. IK Adapter M/L
(code:608770)



2no. IK Pins Ø25
(code:608825)



2no. Spring Cotter Pins 5
(code:174553)



2no. IK Pins Ø16
(code:608816)



2no. Spring Cotter Pins 4
(code:173776)

Step 1 Insert the IK Adapter M/L into the Waler M and fasten with 2no. IK Pins Ø20. Secure the IK Pins with the Spring Cotter Pins. Ensure that the IK Adapter M/L is positioned such that the holes Ø20 are parallel to the Waler M.

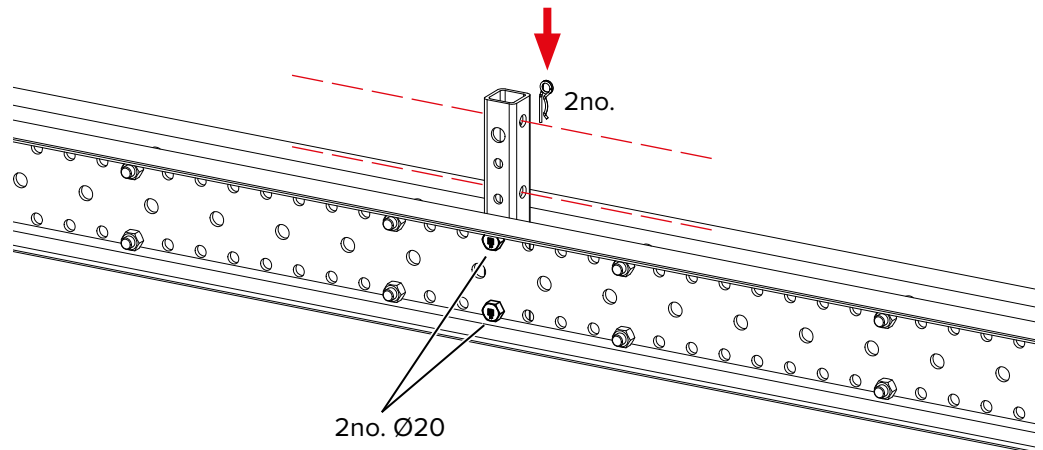

Step 2 Slide the Waler L over the IK Adapter M/L, parallel to the the Waler M. Use 2no. IK Pins Ø16 to secure the IK Waler L. Secure the IK Pins with the Spring Cotter Pins.

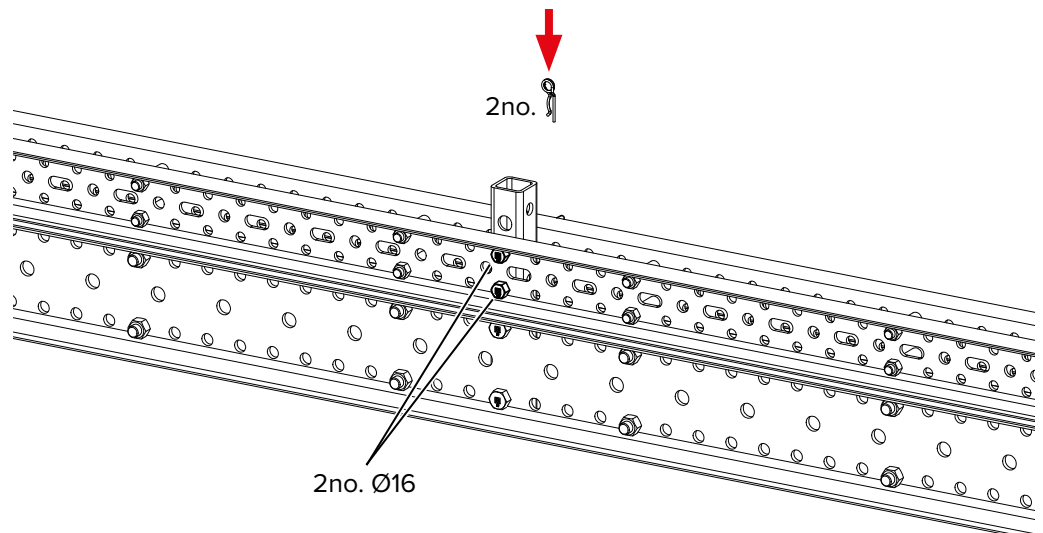

8.4.5 Connecting Waler M to Waler L crosswise

Components needed:

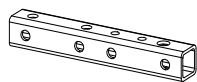

1no. IK Adapter M/L
(code:608770)

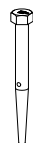

2no. IK Pins Ø25
(code:608825)



2no. Spring Cotter Pins 5
(code:174553)

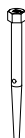

2no. IK Pins Ø16
(code:608816)



2no. Spring Cotter Pins 4
(code:173776)

Step 1 Insert the IK Adapter M/L into the Waler M and fasten with 2no. IK Pins Ø20. Secure the IK Pins with the Spring Cotter Pins. Ensure that the IK Adapter M/L is positioned such that the holes Ø20 are perpendicular to the Waler M.

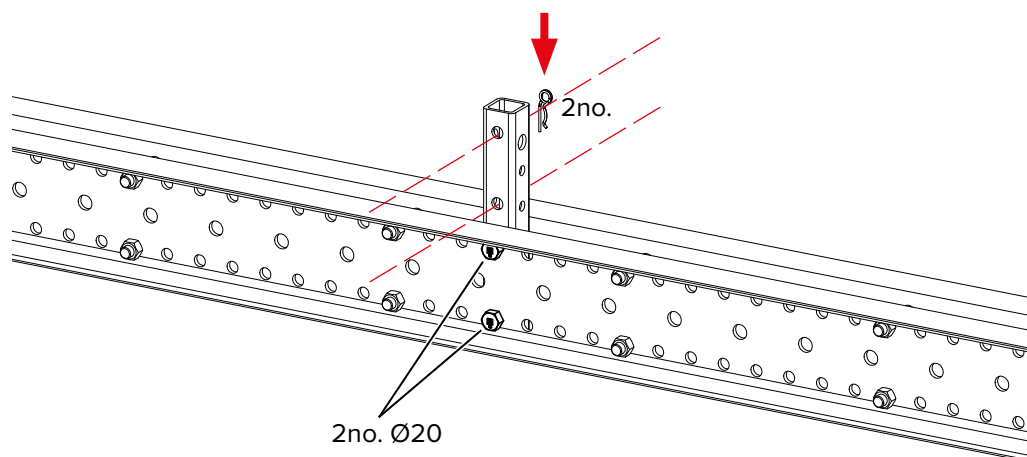

Step 2 Slide the Waler L crosswise over the IK Adapter M/L. Use 2no. IK Pins Ø16 to secure the IK Waler L. Secure the IK Pins with the Spring Cotter Pins.

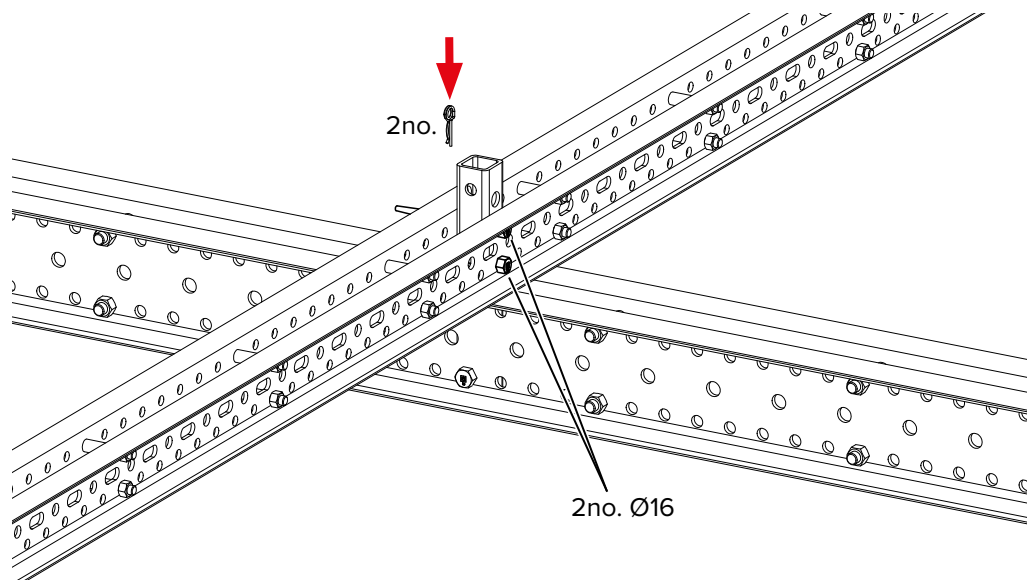

8.5 Articulated connection of walers

The following articulated connections can be created:

- Connecting an IK Waler L to an IK Waler L or an IK Waler M (using the IK Waler Connector Flex L)
- Connecting an IK Waler M to an IK Waler M or an IK Waler L (using the IK Waler Connector Flex M)
- Connecting an IK Waler L/M to an IK Waler L/M (using the IK Adjustable Connector L/M)
- Connecting an IK Waler L directly to an IK Waler M or an IK Waler L (using the IK Adapter L)

The Adjustable Connector can also be adjusted, allowing the walers to be connected outside of the hole grid.

8.5.1 Connecting IK Waler L to IK Waler L or Waler M (using Waler Connector Flex L)

Components needed:

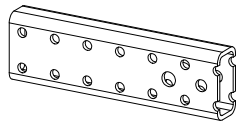

1no. IK Waler Connector Flex L
(code:608490)



1no. IK Pin Ø20
(code:608820)
or 1no. IK Pin Ø25
(code:608825)



6no. IK Pins Ø16
(code:608816)



7no. Spring Cotter Pins 4
(code:173776)
or 6no. Spring Cotter Pins 4
and 1no. Spring Cotter Pin 5
(code:174553)

Step 1 Insert the IK Waler Connector Flex L into the first Waler L and fasten with 6no. IK Pins Ø16. Secure the IK Pins with the Spring Cotter Pins.

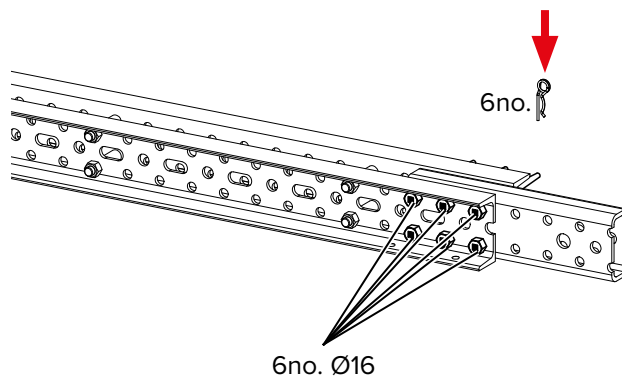

Step 2 Slide the second Waler L over the IK Waler Connector Flex L and fasten with 1no. IK Pin Ø20. Secure the IK Pins with the Spring Cotter Pins.

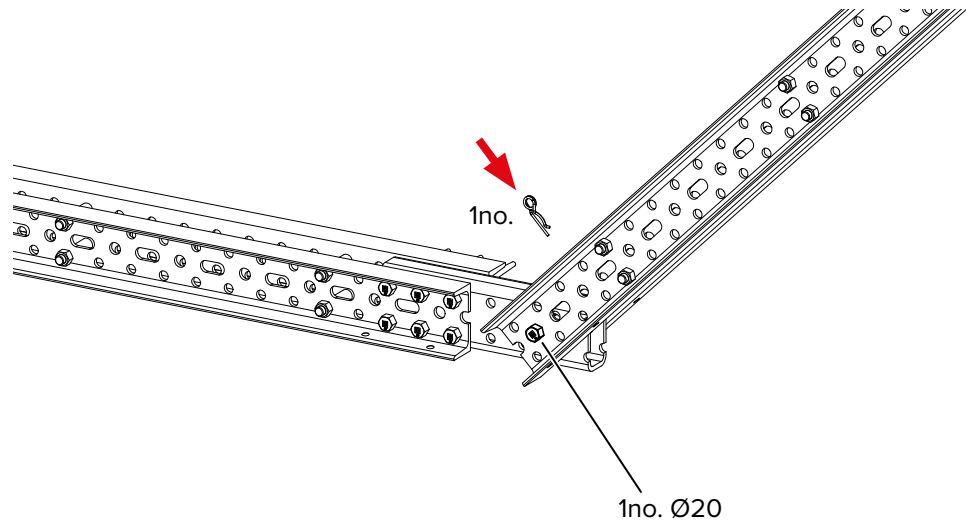

Or slide Waler M over the IK Waler Connector Flex L and fasten with 1no. IK Pin Ø25. Secure the IK Pins with the Spring Cotter Pins.

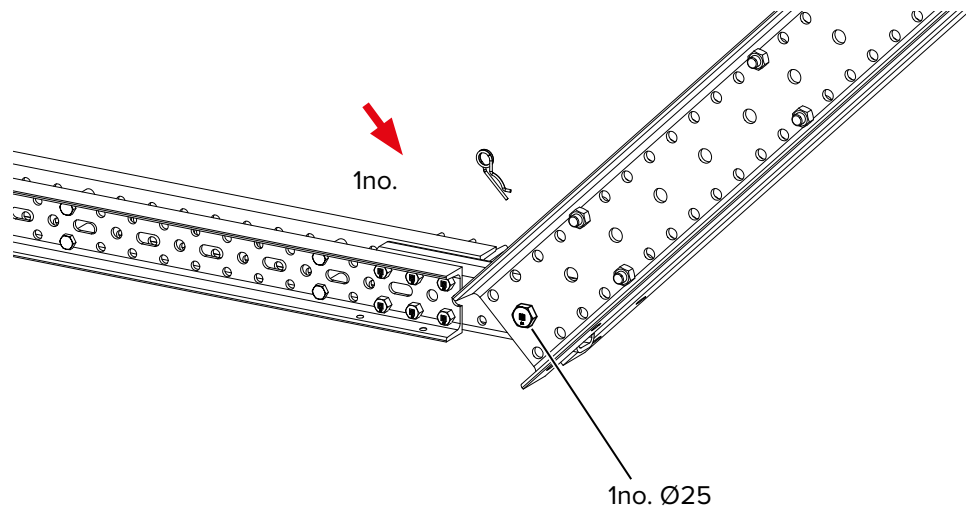

Connecting IK Walers L and M

8.5.2 Connecting Waler M to Waler M or Waler L (using Waler Connector Flex M)

The walers used and the required angle between them will dictate how deep the IK Waler Connector Flex M is inserted on the walers.

Components needed:

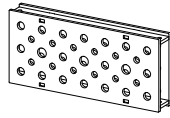

1no. IK Waler Connector Flex M
(code:608485)

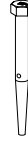

6no. IK Pins Ø20
(code:608820)

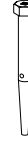

1no. IK Pin Ø20
(code:608820)
or 1no. IK Pin Ø25
(code:608825)



7no. Spring Cotter Pins 4
(code:173776)
or 6no. Spring Cotter Pins 4
and 1no. Spring Cotter Pin 5
(code:174553)

Step 1 Insert the IK Waler Connector Flex M into the first Waler M and fasten with 6no. IK Pins Ø20. Secure the IK Pins with the Spring Cotter Pins. Position the Waler Connector Flex as needed.

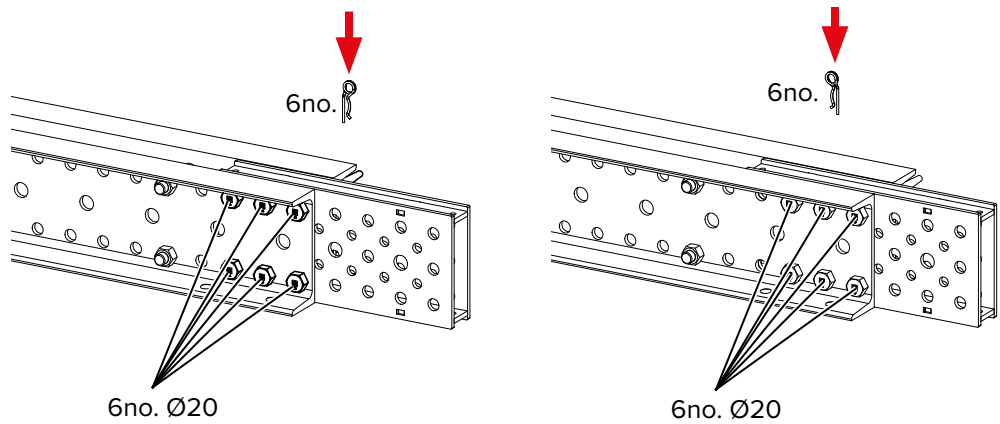

Step 2 Slide the second IK Waler M over the Waler Connector Flex M and fasten in a suitable hole with 1no. IK Pin Ø25. Secure the IK Pins with the Spring Cotter Pins.

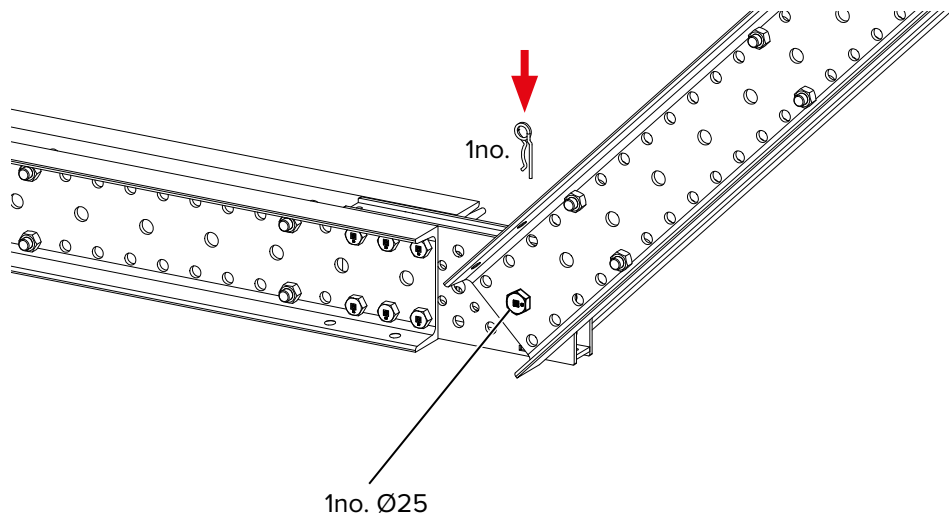

Or slide the Waler L over the Waler Connector Flex M and fasten in a suitable hole with 1no. IK Pin Ø20. Secure the IK Pins with the Spring Cotter Pins.

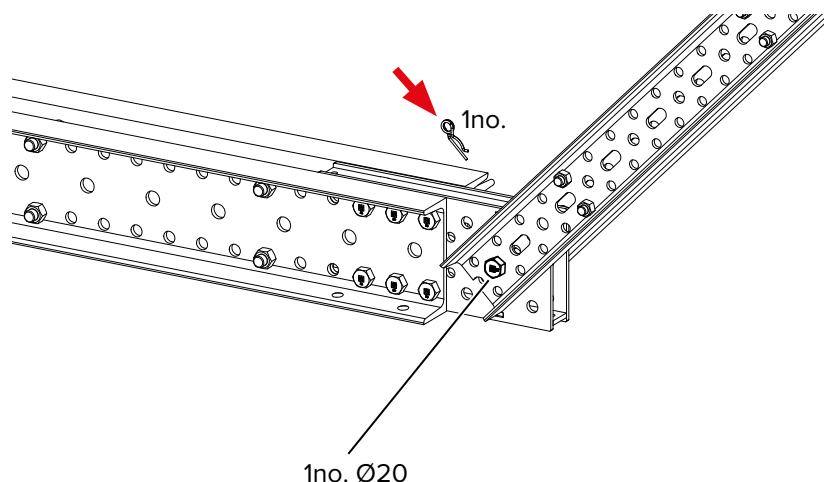

8.5.3 Connecting an IK Waler L/M to an IK Waler L/M (using the IK Adjustable Connector) (code:608850)

A Waler M can be connected to a Waler L using the Adjustable Connector. The Adjustable Connector can also be adjusted, allowing Walers to be connected outside of the hole grid. How to use the Adjustable Connector is described in Section *Articulated connection (outside the hole grid)* on page 81.

8.5.4 Connecting an IK Waler L to an IK Waler L (using the IK Adapter M/L)

Verification of cross-section for all three possible resulting stresses (N, V, M) with linear interaction is required!

Components needed:

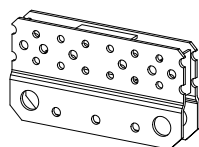

1no. IK Waler Connector L
(code:608420)

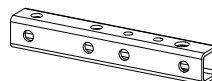

1no. IK Adapter M/L
(code:608770)



3no. IK Pins Ø20
(code:608821)



12no. IK Pins Ø16
(code:608816)



15no. Spring Cotter Pins 4
(code:173776)

Connecting IK Walers L and M

Step 1 Insert the IK Adapter M/L into an IK Waler L and fasten with 2no. IK Pins $\text{\O}20$. Secure the IK Pins with the Spring Cotter Pins. Verify that the hole $\text{\O}26$ faces the flange.

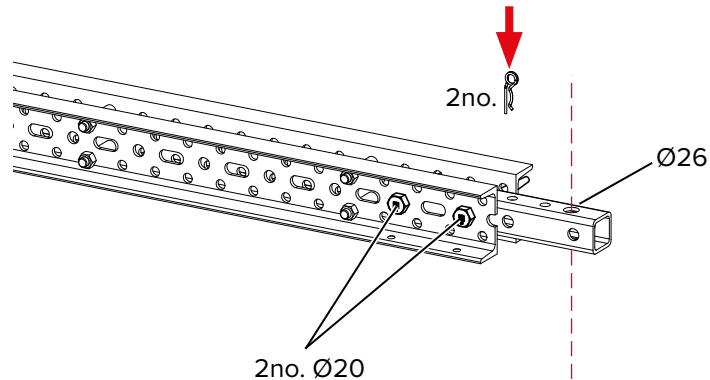

Step 2 Insert the IK Waler Connector L into the Waler L and fasten with 12no. IK Pins $\text{\O}20$. Secure the IK Pins with the Spring Cotter Pins.

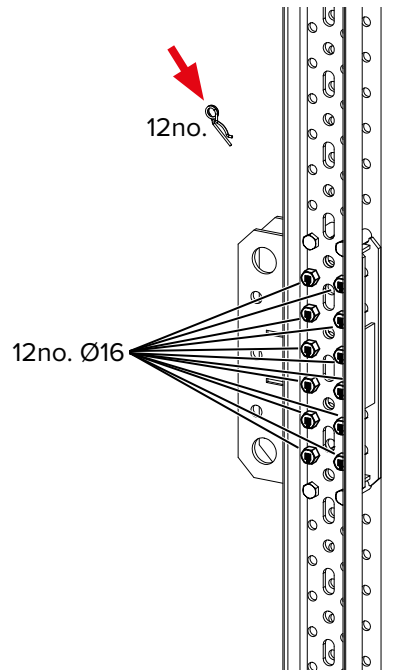

Step 3 Insert the IK Adapter M/L into the IK Waler Connector L and fasten with 1no. IK Pin $\text{\O}20$. Secure the IK Pins with the Spring Cotter Pins.

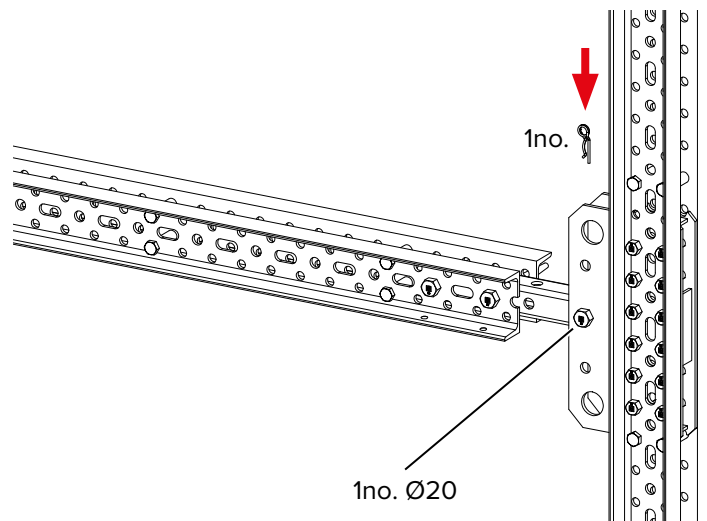

8.5.5 Connecting an IK Waler L to an IK Waler M (using the IK Adapter M/L)

 Verification of cross-section for all three possible resulting stresses (N, V, M) with linear interaction is required!

Components needed:

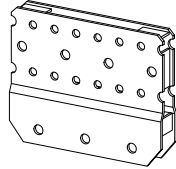

1no. IK Waler Connector M
(code:608430)

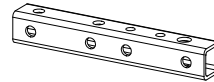

1no. IK Adapter M/L
(code:608770)

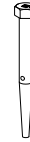

14no. IK Pins Ø20
(code:608821)



1no. IK Pin Ø25
(code:608825)



14no. Spring Cotter Pins 4
(code:173776)



1no. Spring Cotter Pin 5
(code:174553)

Step 1 Insert the IK Adapter M/L into an IK Waler L and fasten with 2no. IK Pins Ø20. Secure the IK Pins with the Spring Cotter Pins. Ensure that the hole Ø26 faces the web.

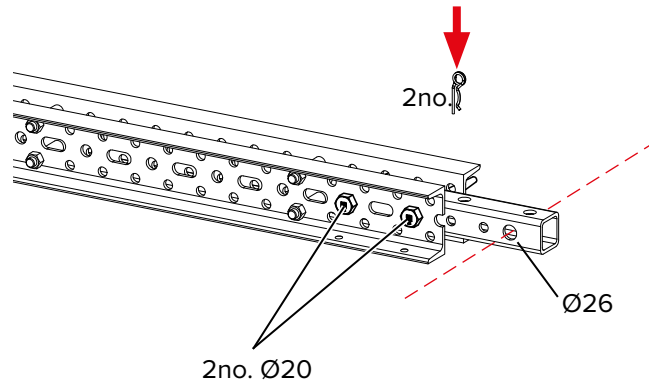

Step 2 Insert the IK Waler Connector L into the IK Waler L and fasten with 12no. IK Pins Ø20. Secure the IK Pins with the Spring Cotter Pins.

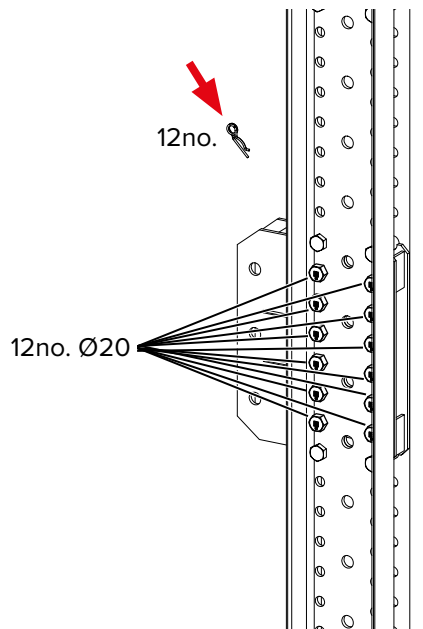

Connecting IK Walers L and M

Step 3 Insert the IK Adapter M/L into the IK Waler Connector and fasten with 1no. IK Pin Ø25. Secure the IK Pins with the Spring Cotter Pins.

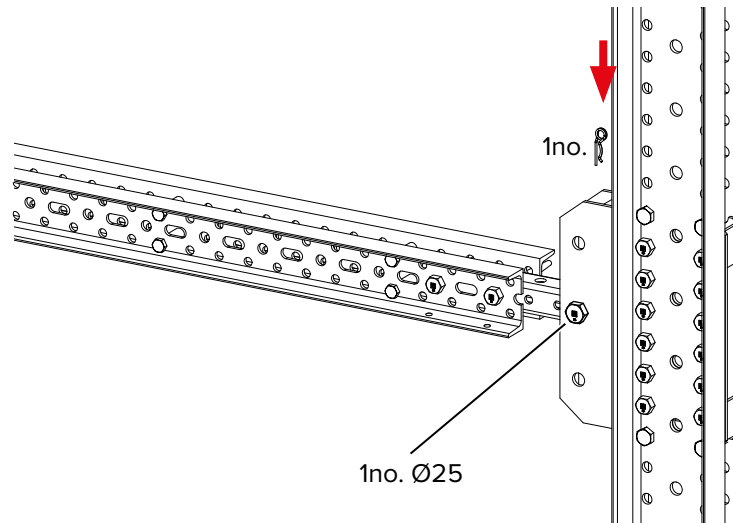

8.5.6 Connecting an IK Waler L directly to an IK Waler L (using the IK Adapter M/L)



Verification of cross-section for all three possible resulting stresses (N, V, M) with linear interaction is required!

A IK Waler L can be connected directly to a Waler L or e.g. to a spindle connector.

Components needed:

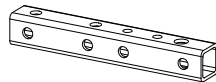

1no. IK Adapter M/L
(code:608770)



3no. IK Pins Ø20
(code:608821)



3no. Spring Cotter Pins 4
(code:173776)

Step 1 Insert the IK Adapter M/L into an IK Waler L and fasten with 2no. IK Pins Ø20. Secure the IK Pins with the Spring Cotter Pins.

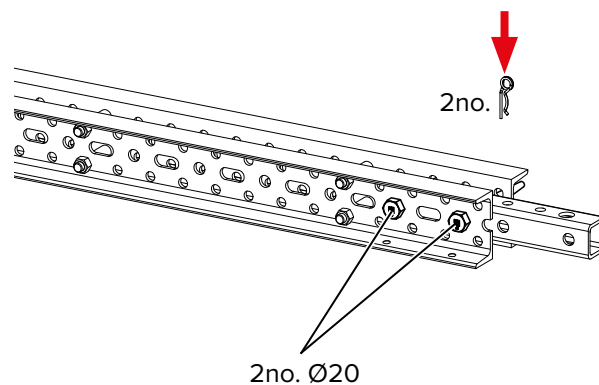

Step 2 Insert the waler and IK Adapter M/L into the Waler or a spindle connector and secure with 1no. IK Pin Ø20. Secure the IK Pins with the Spring Cotter Pins.

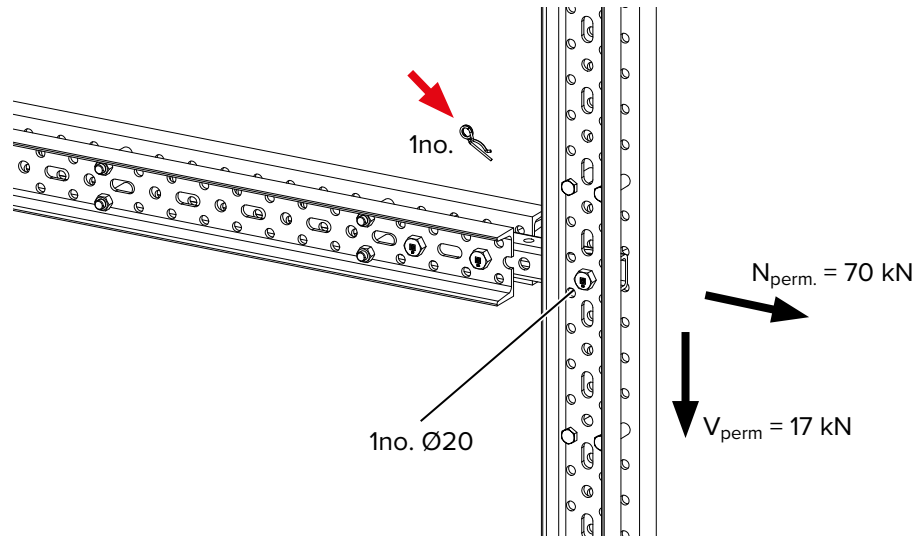

8.5.7 Connecting an IK Waler L directly to an IK Waler M (using IK Adapter L)



Verification of cross-section for all three possible stress resultants (N, V, M) with linear interaction required!

An IK Waler L can be connected directly to a Waler M or e.g. to a spindle connector.

Components needed:

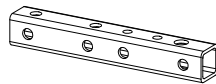

1no. IK Adapter M/L
(code:608770)

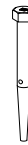

2no. IK Pins Ø20
(code:608820)

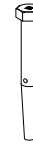

1no. IK Pin Ø25
(code:608825)



2no. Spring Cotter Pins 4
(code:173776)



1no. Spring Cotter Pin 5
(code:174553)

Step 1 Insert the IK Adapter M/L into an IK Waler L and fasten with 2no. IK Pins Ø20. Secure the IK Pins with the Spring Cotter Pins.

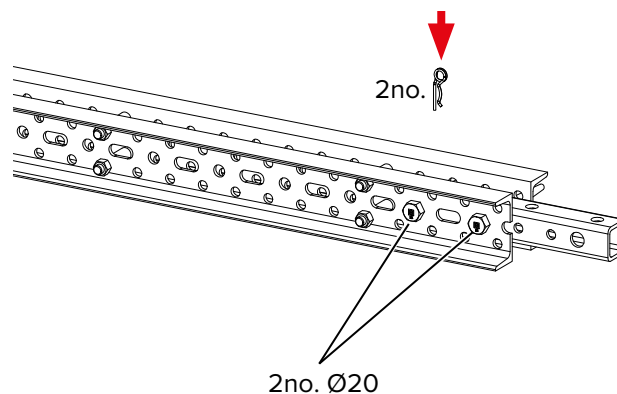

Connecting IK Walers L and M

Step 2 Insert the IK Waler L and the IK Adapter M/L into the IK Waler M or a spindle connector and secure with 1no. IK Pin $\varnothing 25$. Secure the IK Pins with the Spring Cotter Pins.

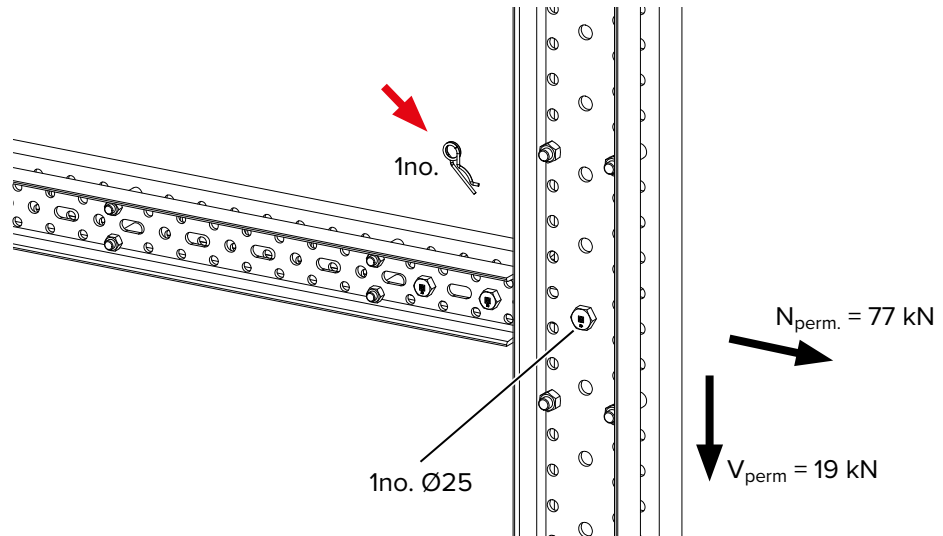

8.6 Articulated connection (using the waler's web)

Additional IK Walers can be connected to the webs of IK Walers using an IK Cross Connector and the IK Adapter M/L.

8.6.1 Connecting Waler L to Waler L



This connection can only take axial loads in relation to the waler's length!

Components needed:

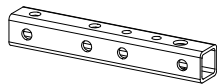

1no. IK Adapter M/L
(code:608770)



3no. IK Pins $\varnothing 20$
(code:608820)



3no. Spring Cotter Pins 4
(code:173776)

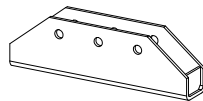

1no. IK Cross Connector L
(code:608450)



4no. Hexagon Bolts
M20 \times 130 with Nuts
(code:608456)

Step 1 Use 4no. Bolts M20 x 130 and Nuts to attach the IK Cross Connector L to an IK Waler L.

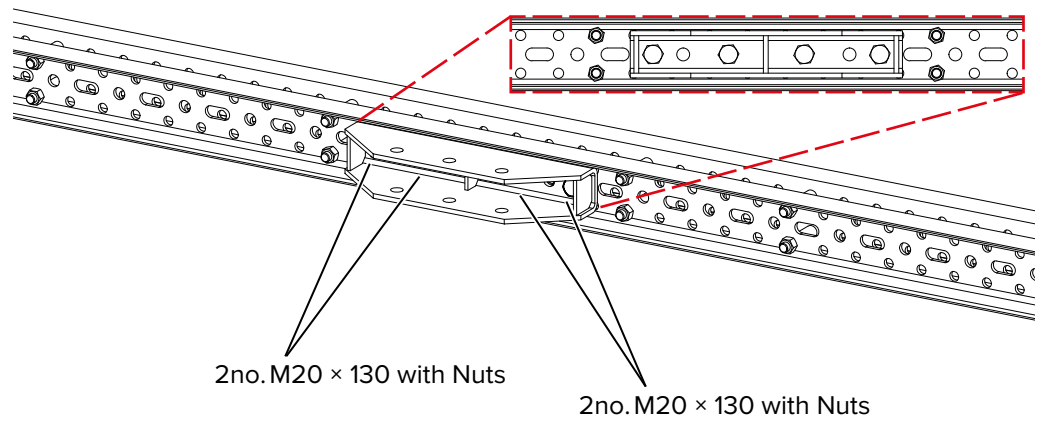

Step 2 Insert the IK Adapter M/L into the IK Cross Connector L and fasten with 1no. Pin Ø20. Secure the Pin with a Spring Cotter Pin.

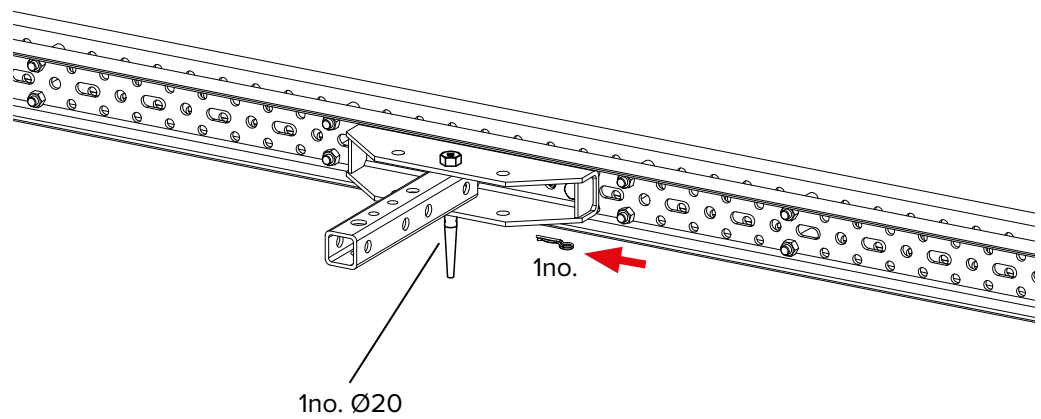

Step 3 Slide the second Waler L over the IK Adapter M/L and fasten with 2no. Pins Ø20. Secure the Pins with the Spring Cotter Pins.

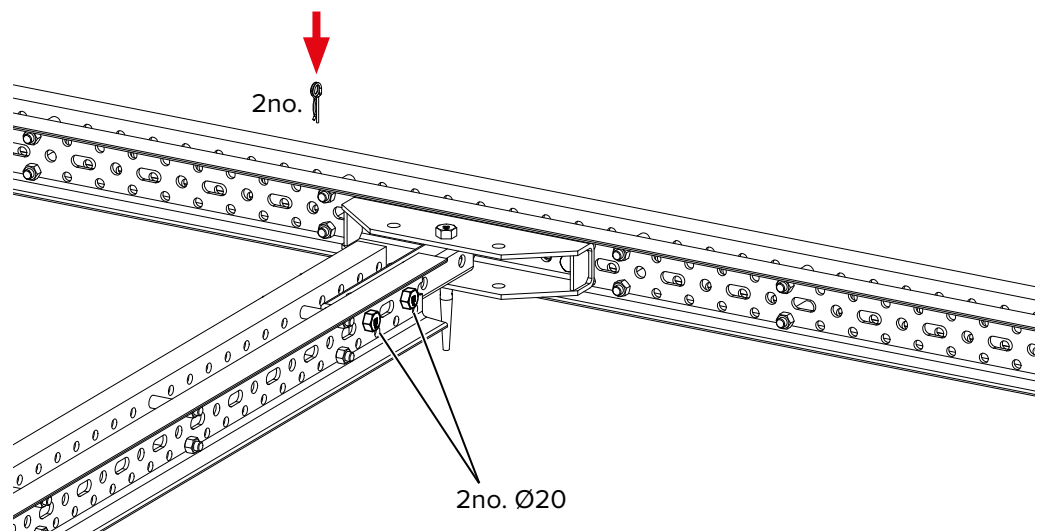

Connecting IK Walers L and M

8.6.2 Connecting an IK Waler L to an IK Waler M



This connection can only take axial loads in relation to the waler's length!

Components needed:

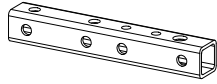

1no. IK Adapter M/L
(code:608770)

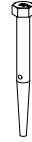

2no. IK Pins Ø20
(code:608820)



2no. Spring Cotter Pins 4
(code:173776)

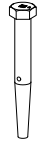

1no. IK Pin Ø25
(code:608825)



1no. Spring Cotter Pin 5
(code:174553)

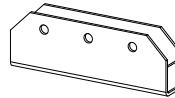

1no. IK Cross Connector M
(code:608470)



4no. Hexagon Bolts
M24 x 130 with Nuts
(code:608475)

Step 1 Use 4no. Bolts M24 x 130 and Nuts to attach the IK Cross Connector M to a Waler M.

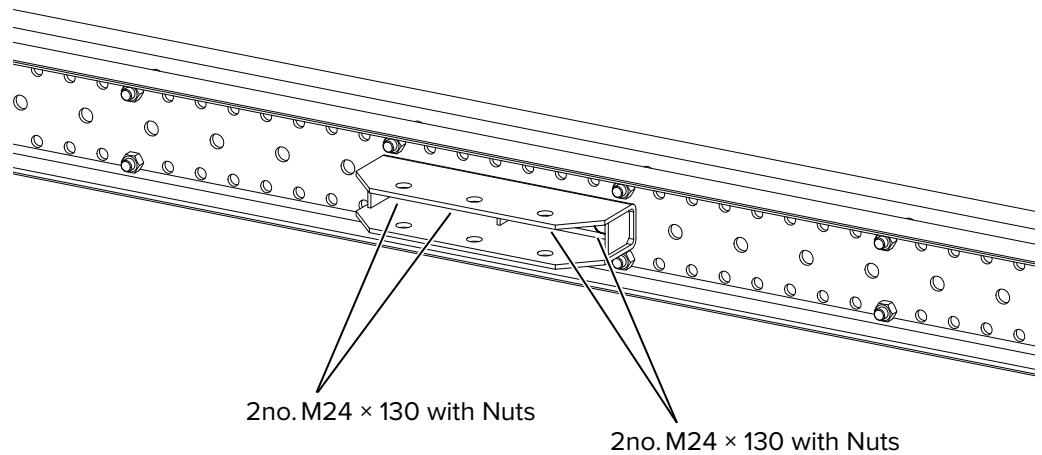

Step 2 Insert the IK Adapter M/L into the IK Cross Connector M and fasten with 1no. Pin Ø25. Secure the Pin with a Spring Cotter Pin.

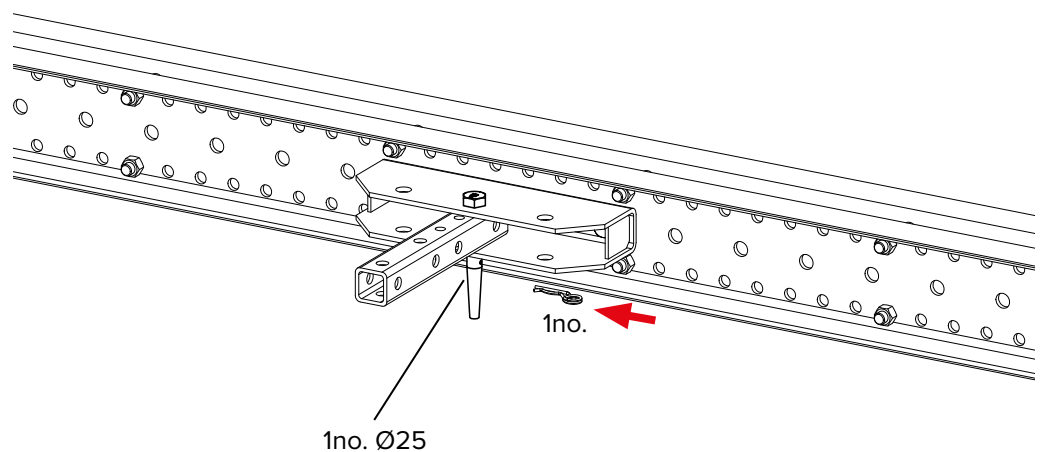

Step 3 Slide the Waler L over the IK Adapter M/L and fasten with 2no. Pins Ø20. Secure the Pins with the Spring Cotter Pins.

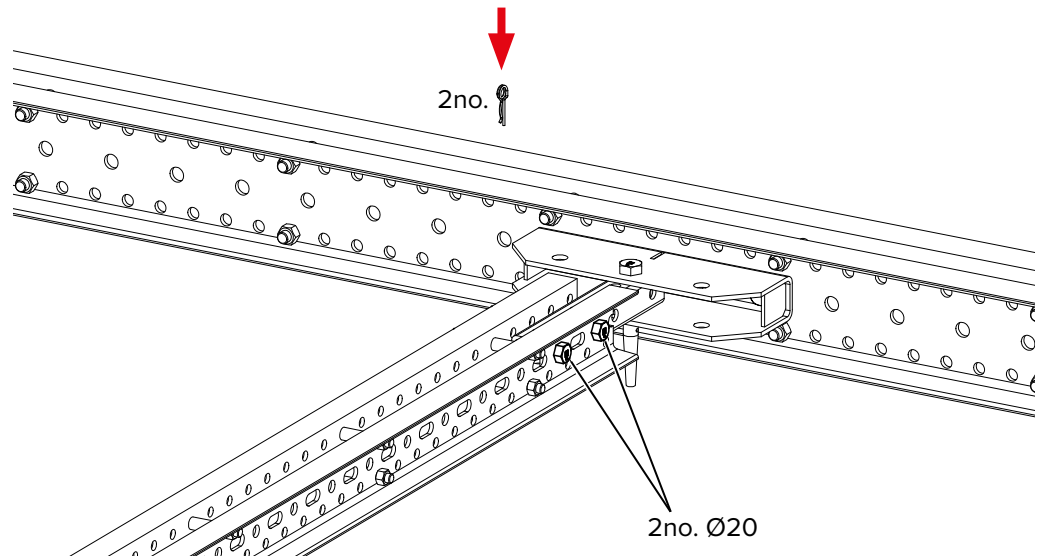

8.7 Articulated connection (outside the hole grid)

Walers can be connected in an articulated way outside of the hole grid using the IK Adjustable Connector L/M. The IK Adjustable Connector L/M is continuously adjustable. It can be adjusted within a range of 0 to 62.5 mm.



First attach the IK Adjustable Connector using 2no. IK Pins Ø20. This allows the position of the IK Adjustable Connector to be easily adjusted and additional walers to be connected.

Before load can be applied to the IK Adjustable Connector, it has to be secured at any position with an additional IK Pin Ø20.



The positions of some of the Waler Bolts have to be changed for this connection (Refer to section 8.1 on page 47).

8.7.1 Attaching the IK Adjustable Connector to an IK Waler L

Components needed:

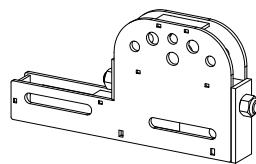

1no. IK Adjustable Connector
(code:608850)



3no. IK Pins Ø20
(code:608820)



3no. Spring Cotter Pins 4
(code:173776)

Connecting IK Walers L and M

Step 1 Slide the IK Adjustable Connector into the Waler L and fasten with 2no. IK Pins Ø20. Secure the IK Pins with the Spring Cotter Pins.

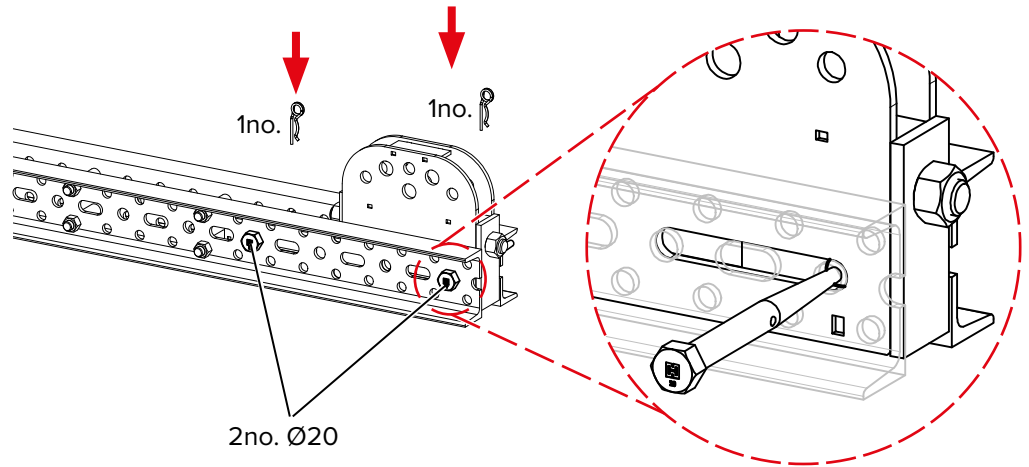

8.7.2 Attaching the IK Adjustable Connector to an IK Waler M

Components needed:

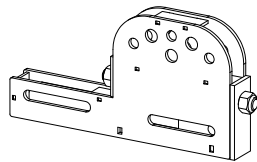

1no. IK Adjustable Connector
(code:608850)



2no. IK Pins Ø20
(code:608820)



2no. Spring Cotter Pins 4
(code:173776)

Step 1 Slide the IK Waler Connector into the Waler M and fasten with 2no. IK Pins Ø20. Secure the IK Pins with the Spring Cotter Pins.

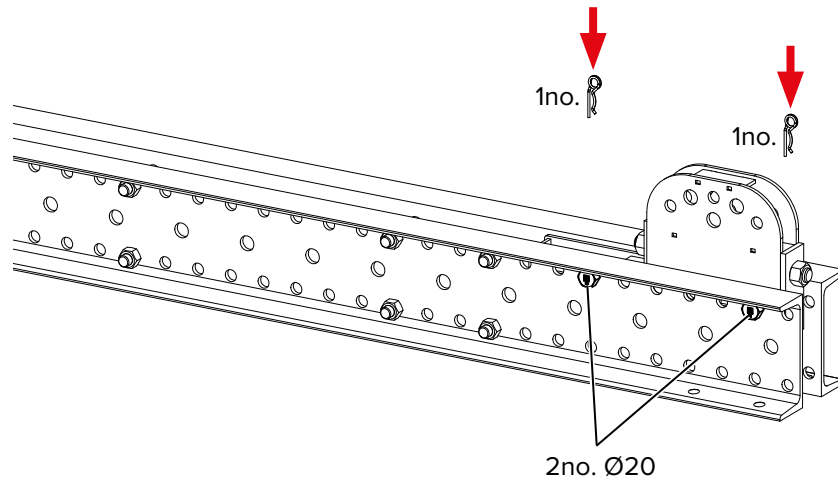

8.7.3 Attaching an IK Waler M to the IK Adjustable Connector

Components needed:



1no. IK Pin Ø25
(code:608825)



1no. Spring Cotter Pin 5
(code:174553)

Step 1 Slide the Waler M over the IK Adjustable Connector and fasten with 1no. IK Pin Ø25. Secure the IK Pin with a Spring Cotter Pin (not shown here).

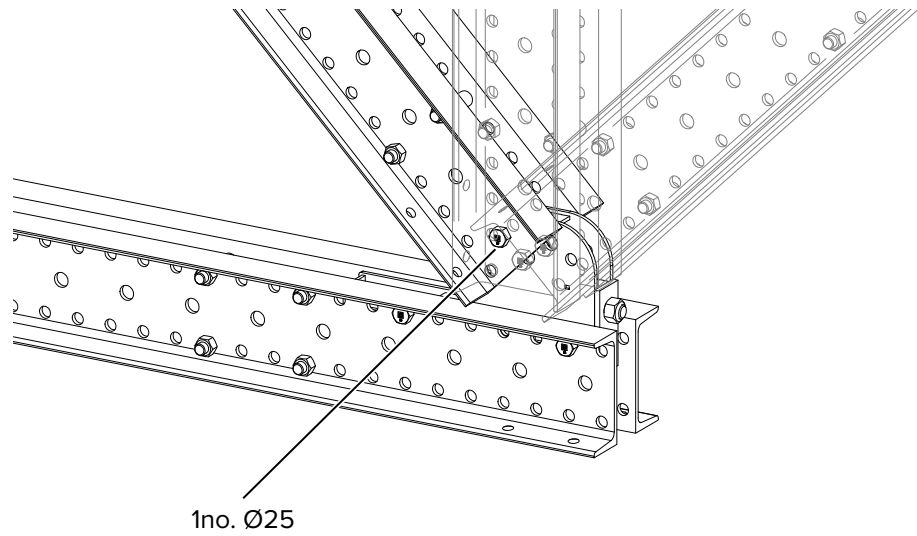

8.7.4 Attaching an IK Waler L to the IK Adjustable Connector

Components needed:



1no. IK Pin Ø20
(code:608820)



1no. Spring Cotter Pin 4
(code:173776)

Step 1 Slide the Waler L over the IK Adjustable Connector and fasten with 1no. IK Pin Ø20. Secure the IK Pins with a Spring Cotter Pins (not shown here).

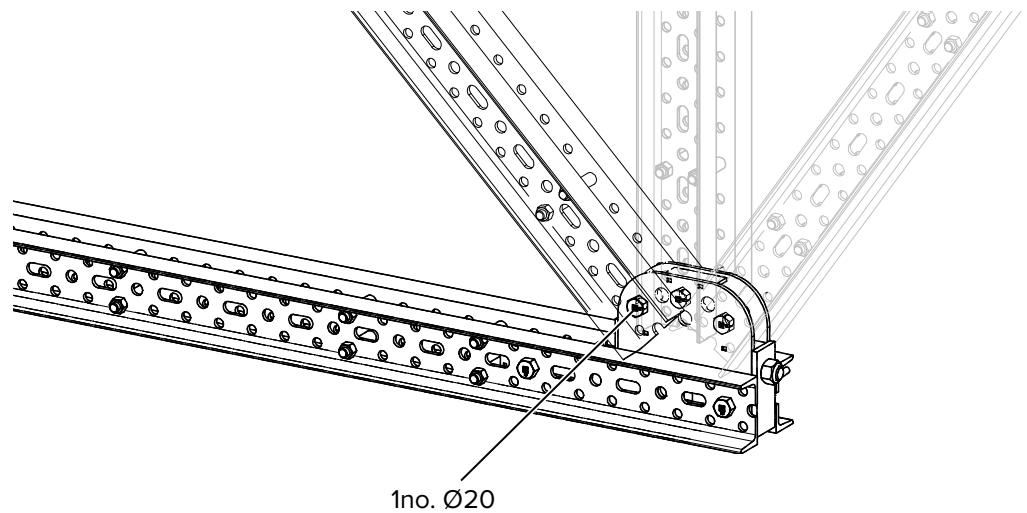

Connecting IK Walers L and M

8.7.5 Operating the IK Adjustable Connector

The IK Adjustable Connector is operated using the MANTO Ratchet or with a spanner w.a.f. 36. It can be adjusted within a range of ± 62.5 mm.

Step 1 Adjust the IK Adjustable Connector.

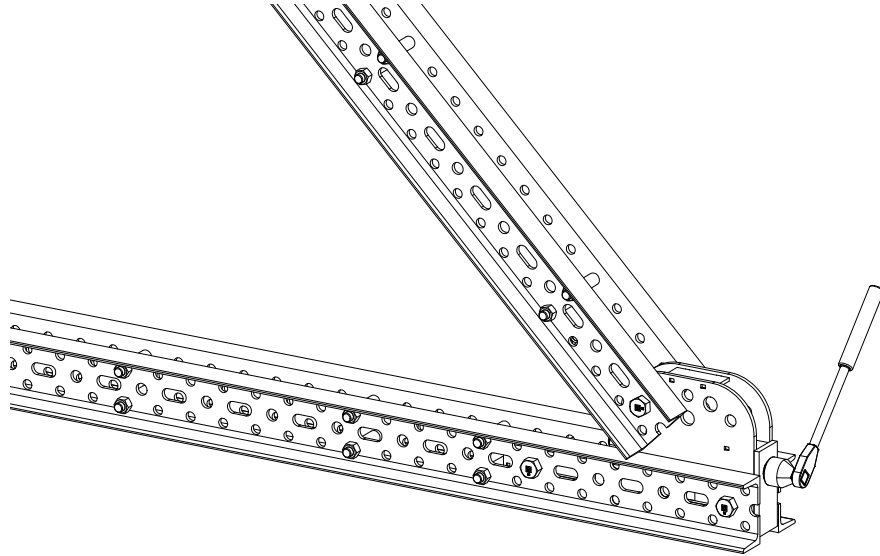

Step 2 Secure the IK Adjustable Connector with a third IK Pin $\varnothing 20$.

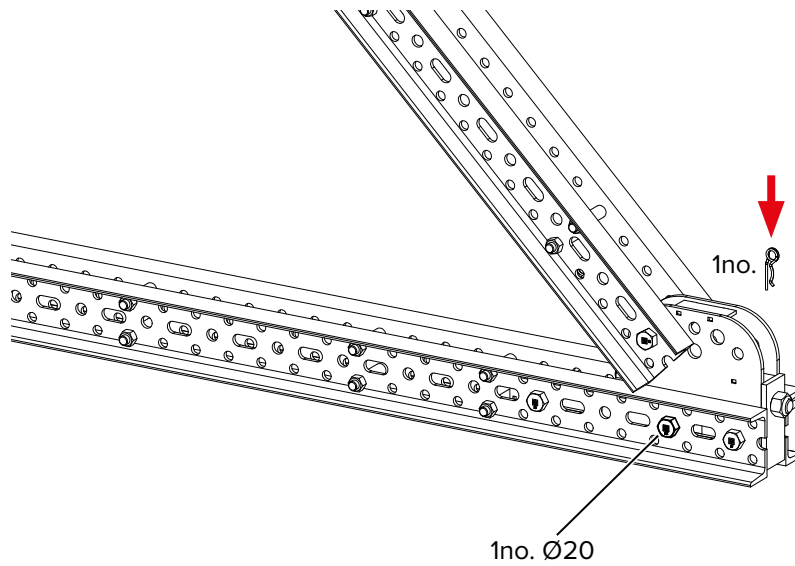

9 Attaching jacks and bases

The IK Jacks are used to securely position the INFRA-KIT assemblies on the ground and adjust the height.

The IK Wheel Connector and the Heavy-duty Castors can be used to create mobile INFRA-KIT assemblies. Use the IK Jacks to raise and lower the assemblies.

9.1 Attaching the IK Jack 180

The IK Jacks 180 can be attached to horizontal as well as vertical IK Walers M. This section shows how to attach to a horizontal waler.



The Waler should normally rest on the support plate. In this case the waler can be secured with IK Pins. If in exceptional cases the upper holes have to be used and the waler cannot rest on the support plate, the waler has to be secured with Bolts M20 × 130 (code:608456) instead of with IK Pins!



Ensure that the exact side of the waler is resting on the support plate.

On Waler M this is the side without flange bores!

This is the only way that the waler can rest completely on the support plate!

Waler M

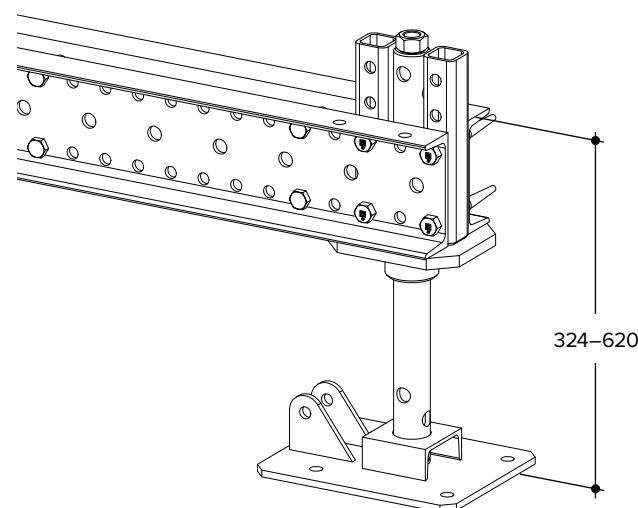

Components needed:

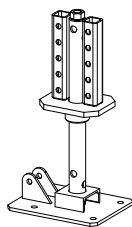

1no. IK Jack 180 M
(code:608775)



4no. IK Pins Ø20
(code:608820)



4no. Spring Cotter Pins 4
(code:173776)

Attaching jacks and bases

Step 1 Set the IK Jack to the desired height. Do this by turning the spindle with a spanner w.a.f. 46 or a suitable tool such as a tie rod.

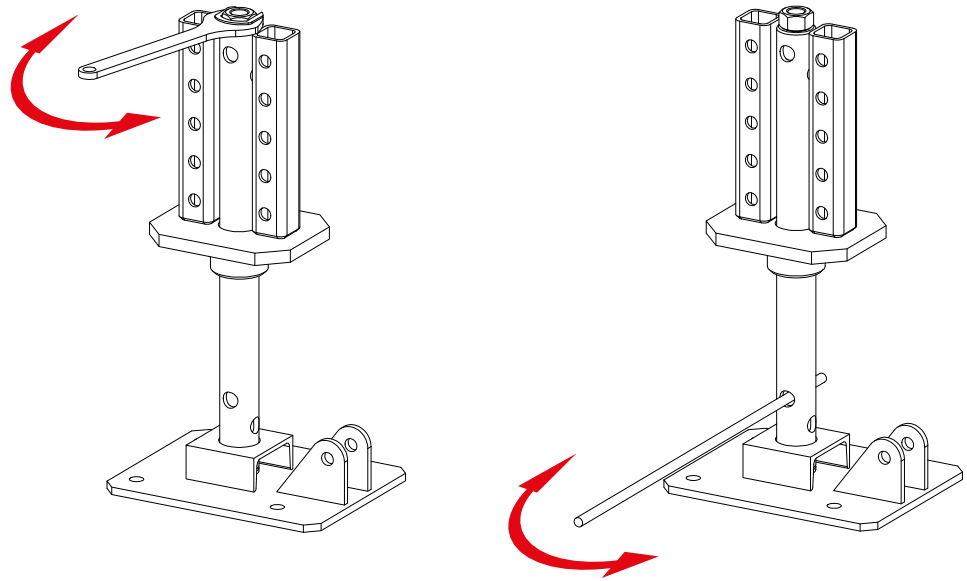

Step 2 Slide the IK Jack into the Waler M and fasten with 4no. IK Pins Ø20. Secure the IK Pins with the Spring Cotter Pins.

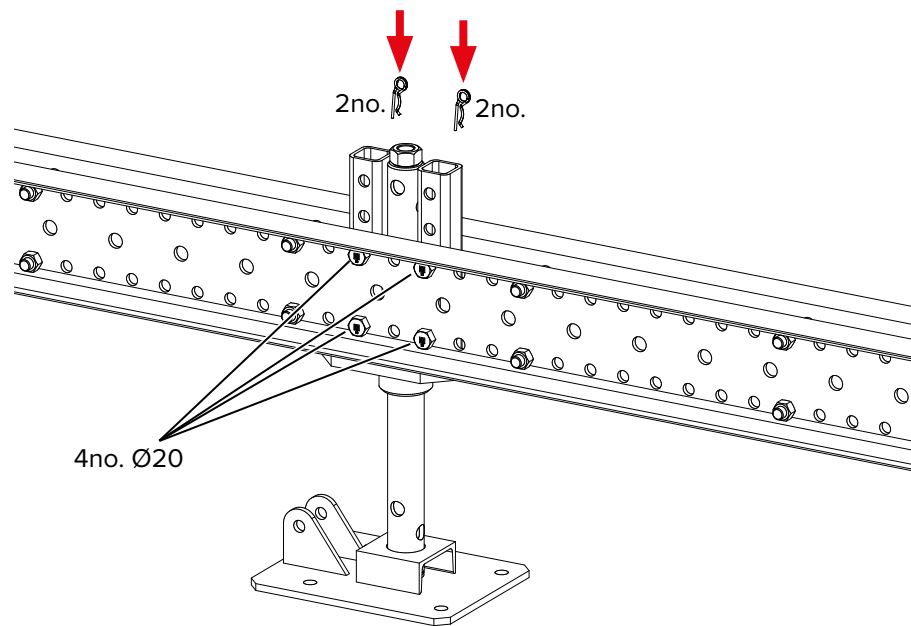

9.2 Attaching the IK Wheel Connector L/M and Heavy-duty Castors

Heavy-duty Castors can be attached to horizontal IK Walers M or L with the IK Wheel Connector L/M (code:608600). The IK Wheel Connector has holes Ø21 for IK Pins Ø20 that enable it to be attached to IK Walers M and holes Ø17 for IK Pins Ø16 that enable it to be attached to IK Walers L. This section shows how to attach to an IK Waler M.

First attach the Heavy-duty Castors to the IK Wheel Connector. Then attach both to the Waler.

9.2.1 IK Wheel Connector L/M

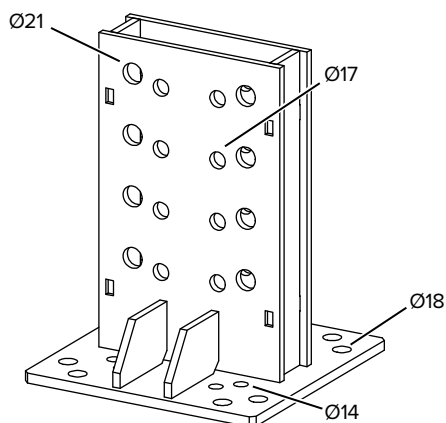

9.2.2 Attaching the Heavy-duty Castors to IK Wheel Connector L/M

The Heavy-duty Castors can be attached to the IK Wheel Connector L/M. Use the bolts with nyloc nuts and washers indicated below to attach the Heavy-duty Castors.

The following table shows the bolts for the respective castors.

Heavy-duty Castor Load-bearing capacity	Head Setscrew	Nut	Washer	Spanner size
30.00 kN	M12×65 code:608627	M12-10 code:608622	12-200 code:608632	18/19
60.00 kN	M16 × 65 code:608628	M16-10 code:608623	16-200 code:608633	24

A Swivel Castor is used as an example. Other Heavy-duty Castors are connected in the same way.

Components needed:

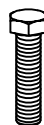
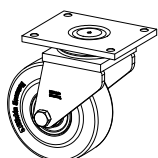

1no. Heavy-duty Castor 4no. Hexagon Bolts

4no. Nuts

4no. Washers

Step 1 Use the 4no. Bolts with nyloc nuts and washers to secure the Heavy-duty Castor to the IK Wheel Connector. Tighten the bolts.

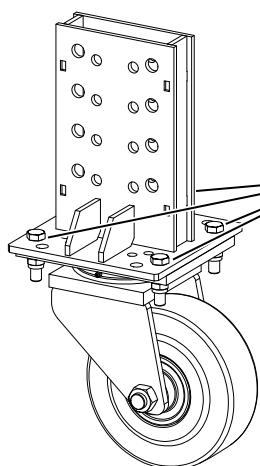

4no. Hexagon Bolts M12/M16 × 65
4No. Hexagon Nyloc Nuts M12/M16-10
4no. Washers M12/M16-200

Attaching jacks and bases

9.2.3 Attaching the IK Wheel Connector L/M to IK Walers



The Waler should normally rest on the support plate. In this case the waler can be secured with IK Pins. If in exceptional cases the upper holes have to be used and the waler cannot rest on the support plate, the waler has to be secured with Bolts M20 × 130 (code:608456).



Ensure that the exact side of the waler is resting on the support plate.

On Waler M this is the side without flange bores!

This is the only way that the waler can rest completely on the support plate!

Components needed:

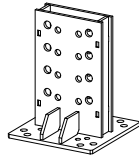

1no. IK Wheel Connector L/M
(code:608600)



4no. IK Pins Ø20
(code:608820)



4no. Spring Cotter Pins 4
(code:173776)

Step 1 Slide the IK Wheel Connector into the Waler M and fasten with 2no. IK Pins Ø20. Secure the IK Pins with the Spring Cotter Pins.

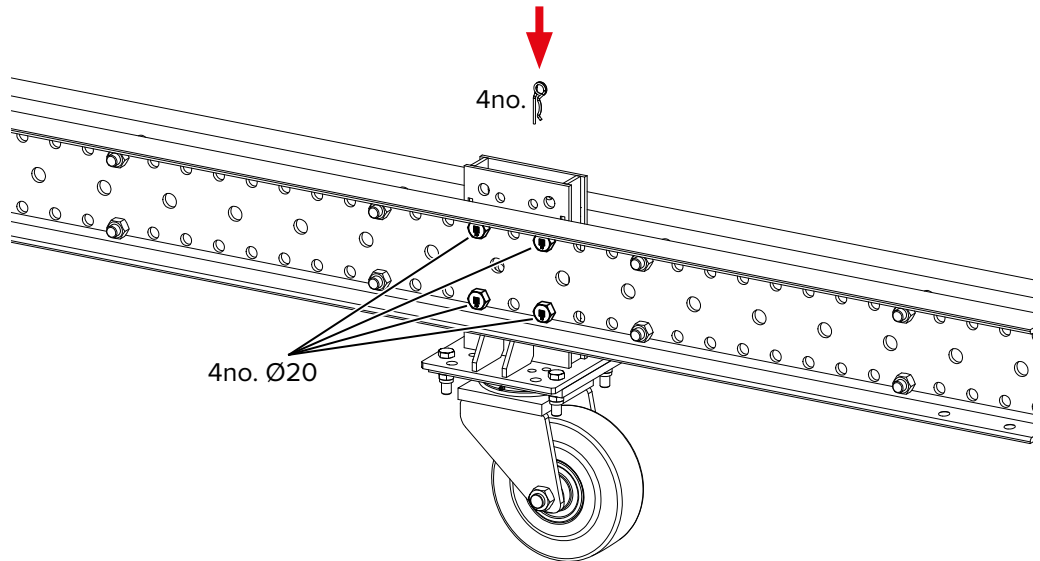

10 IK Spindles

Spindles support the Walers of the INFRA-KIT L and M system. The length of the Spindles can be adjusted. Spindles are available in lengths from 0.5 - 4.80 m. The Spindles can be connected directly to the Walers or by using various components.

10.1 Safe Working Loads

10.1.1 IK Spindle L

IK Spindle 35/50 L	With Waler L F _{perm.} [kN]		With Waler M F _{perm.} [kN]	
	Ø16	Ø20	Ø20	Ø25
Extension [m]				
0.35	61.00	77.00	108.00	142.00
0.50	61.00	77.00	108.00	137.00

IK Spindle 50/75 L	With Waler L F _{perm.} [kN]		With Waler M F _{perm.} [kN]	
	Ø16	Ø20	Ø20	Ø25
Extension [m]				
0.50	61.00	77.00	108.00	137.00
0.75	61.00	77.00	108.00	113.00

IK Spindle 65/100 L	With Waler L F _{perm.} [kN]		With Waler M F _{perm.} [kN]	
	Ø16	Ø20	Ø20	Ø25
Extension [m]				
0.65	61.00	77.00	108.00	130.00
1.00	61.00	77.00	97.00	97.00

IK Spindle 90/155 L	With Waler L F _{perm.} [kN]		With Waler M F _{perm.} [kN]	
	Ø16	Ø20	Ø20	Ø25
Extension [m]				
0.90	61.00	77.00	108.00	120.00
1.20	61.00	77.00	90.00	90.00
1.55	56.00	56.00	56.00	56.00

IK Spindle 140/240 L	With Waler L F _{perm.} [kN]		With Waler M F _{perm.} [kN]	
	Ø16	Ø20	Ø20	Ø25
Extension [m]				
1.40	61.00	77.00	97.00	97.00
1.60	61.00	77.00	80.00	80.00
1.80	61.00	67.00	67.00	67.00
2.00	50.00	50.00	50.00	50.00
2.40	30.00	30.00	30.00	30.00

10.1.2 IK Spindles

IK Spindle 70/110	With Waler L F _{perm.} [kN]		With Waler M F _{perm.} [kN]	
	Ø20		Ø20	Ø25
Extension [m]				
0.70–1.10	77.00		108.00	142.00

IK Spindle 100/170	With Waler L F _{perm.} [kN]		With Waler M F _{perm.} [kN]	
	Ø20		Ø20	Ø25
Extension [m]				
1.00–1.40	77.00		108.00	142.00
1.60	77.00		108.00	137.00
1.70	77.00		108.00	127.00

IK Spindle 140/240	With Waler L	With Waler M	
	F _{perm.} [kN]	F _{perm.} [kN]	
Extension [m]	Ø20	Ø20	Ø25
1.40–1.60	77.00	108.00	142.00
2.20	77.00	103.00	103.00
2.40	77.00	87.00	87.00

IK Spindle 200/300	With Waler L	With Waler M	
	F _{perm.} [kN]	F _{perm.} [kN]	
Extension [m]	Ø20	Ø20	Ø25
2.00	77.00	108.00	142.00
2.40	77.00	108.00	127.00
2.60	77.00	107.00	107.00
3.00	73.00	73.00	73.00

IK Spindle 260/360	With Waler L	With Waler M	
	F _{perm.} [kN]	F _{perm.} [kN]	
Extension [m]	Ø20	Ø20	Ø25
2.60	77.00	108.00	123.00
3.00	77.00	97.00	97.00
3.40	77.00	80.00	80.00
3.60	67.00	67.00	67.00

IK Spindle 320/420	With Waler L	With Waler M	
	F _{perm.} [kN]	F _{perm.} [kN]	
Extension [m]	Ø20	Ø20	Ø25
3.20	77.00	100.00	100.00
3.60	77.00	80.00	80.00
4.00	63.00	63.00	63.00
4.20	53.00	53.00	53.00

IK Spindle 380/480	With Waler L	With Waler M	
	F _{perm.} [kN]	F _{perm.} [kN]	
Extension [m]	Ø20	Ø20	Ø25
3.80	77.00	77.00	77.00
4.20	60.00	60.00	60.00
4.60	47.00	47.00	47.00
4.80	40.00	40.00	40.00

10.2 Possible connection points and extension lengths of IK Spindles

10.2.1 IK Spindles

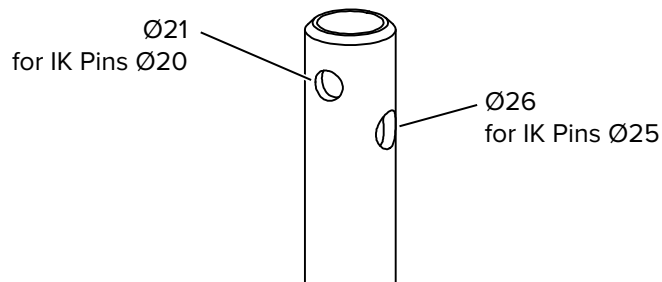

10.2.2 IK Spindle L

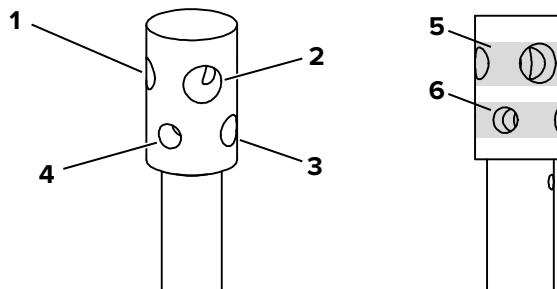

- 1 Hole Ø21 for IK Pin Ø20
- 2 Hole Ø26 for IK Pin Ø25
- 3 Hole Ø17 for IK Pin Ø16
- 4 Hole Ø21 for IK Pin Ø20
- 5 Fastening row Ø17/Ø21
- 6 Fastening row Ø21/Ø25

IK Spindle	Extension length when attaching at fastening row Ø17/Ø21		Extension length when attaching at fastening row Ø21/Ø25		Dimensions	
	Min.	max.	Min.	max.	Min.	max.
35/50 L	352	466	427	541*	490	604
50/75 L	502	732	577	807*	640	870
65/100 L	652	982	727	1057*	790	1120
90/155 L	902	1532	977	1607*	1040	1670
140/240 L	1402	2382	1477	2457*	1540	2520

* For extension lengths greater than the nominal extension lengths, use the next-larger spindle.



Use the inner bores for the shortest extension of IK Spindles L.

To attach to other components such as IK Cross Connectors, use the outer bores.

10.3 Connecting IK Spindles directly to IK Walers L

IK Spindles can be connected directly to both IK Walers M and IK Walers L. There are two holes at the end of each IK Spindle for this purpose.

10.3.1 Connecting an IK Spindle to an IK Waler L

Components needed:



1no. IK Pin Ø16
(code:608816)
or
1no. IK Pin Ø20
(code:608820)



1no. Spring Cotter Pin 4
(code:173776)

Step 1 Fasten the IK Spindle to the bore in an IK Waler L with 1no. IK Pin Ø16 or 1no. IK Pin Ø20. Secure the IK Pin with the Spring Cotter Pin.

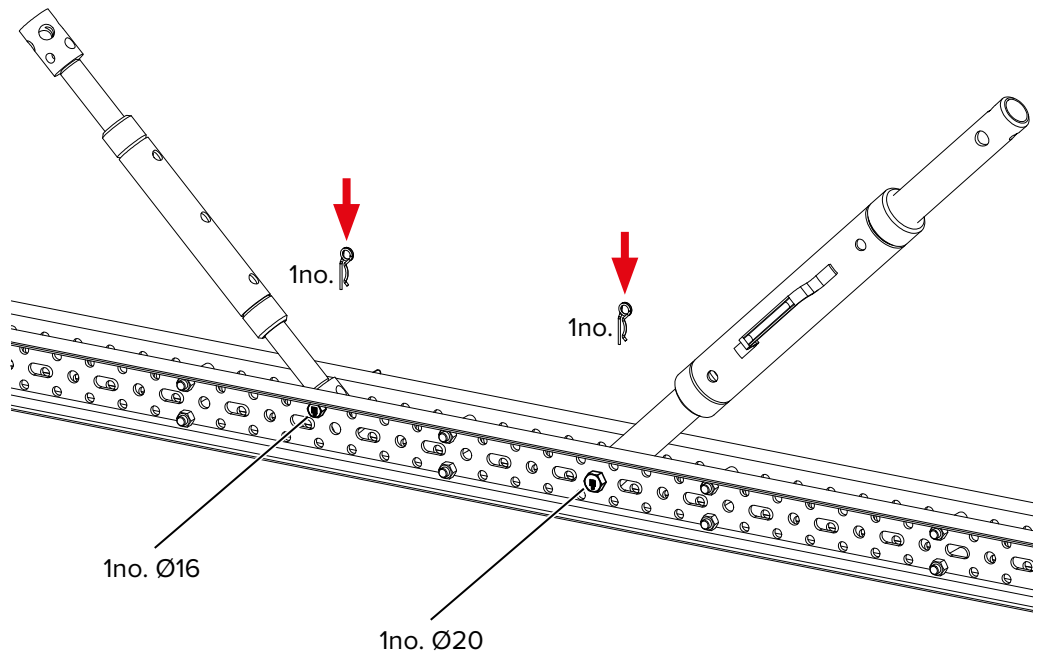

10.3.2 Connecting an IK Spindle to an IK Waler M

Components needed:



1no. IK Pin Ø20
(code:608820)
or
1no. IK Pin Ø25
(code:608825)



1no. Spring Cotter Pin 4
(code:173776)
or
1no. Spring Cotter Pin 5
(code:174553)

Step 1 Fasten the IK Spindle to the bore in an IK Waler M with 1no. IK Pin Ø20 or 1no. IK Pin Ø25. Secure the IK Pin with the Spring Cotter Pin.

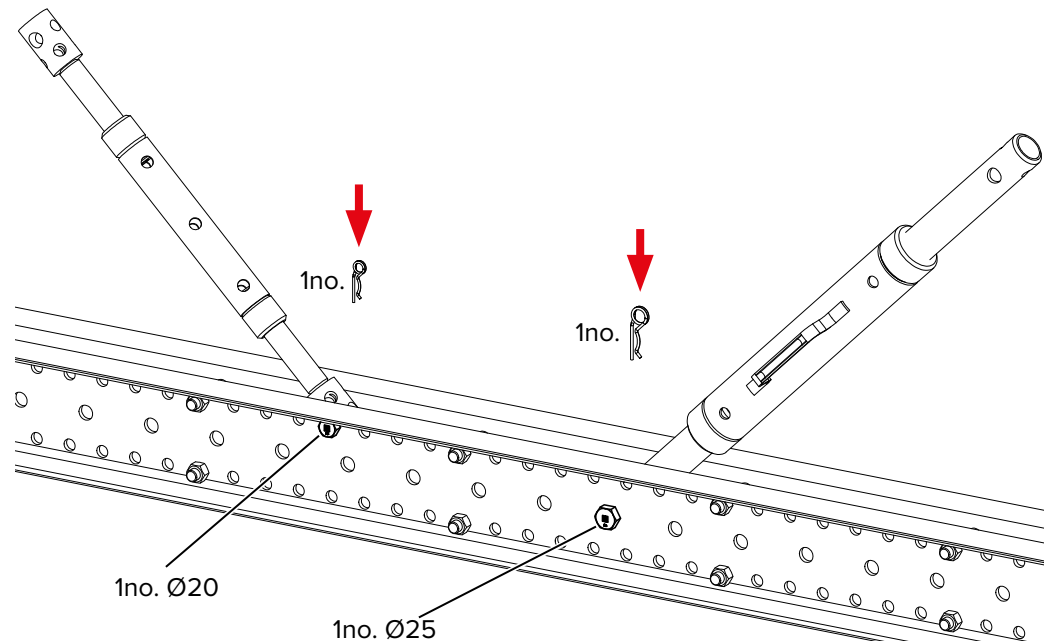

10.4 Connecting IK Spindles to other components

IK Spindles can be connected to various components. These components are:

- IK Waler Connector (Also refer to page 48)
- IK Adapter Waler Connector (Also refer to page 50)
- IK Cross Connector (Also refer to page 52)

The components can either be used as connectors to connect two IK Walers, as described in Section *Connecting IK Walers L and M* on page 46. Or the components can be connected anywhere along an IK Waler.

If connected along an IK Waler, the components can be attached to the centre row of holes. Since assembly is identical, only the completed states are shown.

This section describes how to connect an IK Spindle to a component. The procedure is the same for all components. Use IK Pins Ø25 for components attached to IK Walers M. Use IK Pins Ø20 for components attached to IK Walers L.

Components needed:



1no. IK Pin Ø20
(code:608820)
or
1no. IK Pin Ø25
(code:608825)



1no. Spring Cotter Pin 4
(code:173776)
or
1no. Spring Cotter Pin 5
(code:174553)

Step 1 Use an IK Pin Ø20 (IK Waler L) to fasten the IK Spindle to the component. Secure the IK Pin with a Spring Cotter Pin.

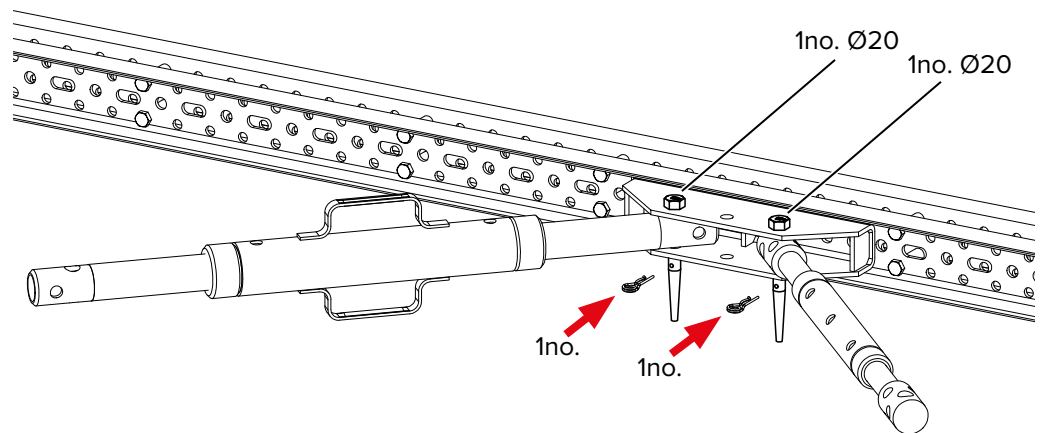

Or use an IK Pin Ø25 (IK Waler M) to fasten the IK Spindle to the component. Secure the IK Pin with a Spring Cotter Pin.

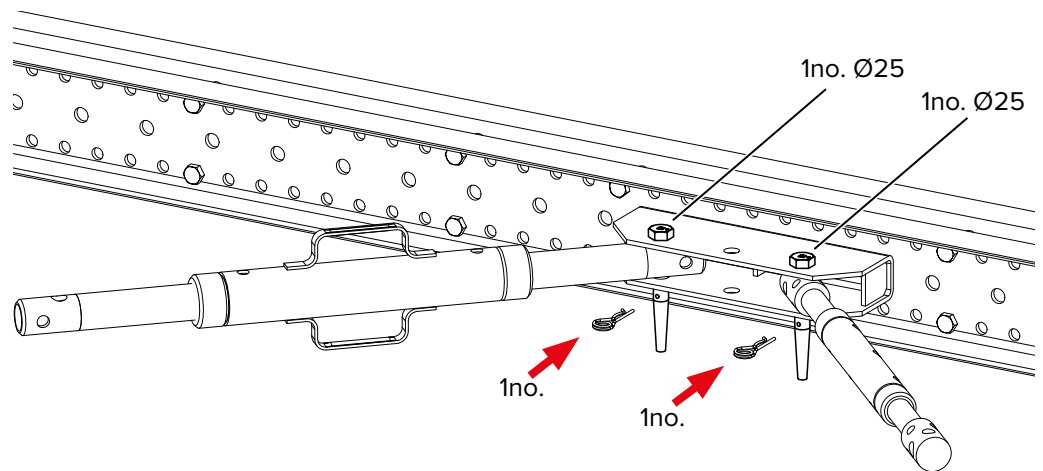

11 Bracing

IK Walers can be braced with $\varnothing 48.3$ mm scaffold tubes. The scaffold tubes are connected to Walers L and M using the IK Scaffold Tube Adapter L/M.

In addition, scaffold tube couplers can be attached to the flange bores in the IK Walers M.

The scaffold tubes cannot transfer loads out of the structure. They can only be used to brace the IK Walers.



The capacity of the bracing to withstand the imposed loads has to be checked separately!

11.1 Attaching the IK Scaffold Tube Adapter

11.1.1 Attaching the IK Scaffold Tube Adapter to an IK Waler L

Components needed:

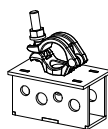

1no. IK Scaffold Tube Adapter
(code:608495)



2no. IK Pins $\varnothing 16$
(code:608816)



2no. Spring Cotter Pins 4
(code:173776)

Step 1 Insert the IK Scaffold Tube Adapter into an IK Waler L and fasten to the top row of holes with 2no. IK Pins $\varnothing 16$. Secure the IK Pins with the Spring Cotter Pins.

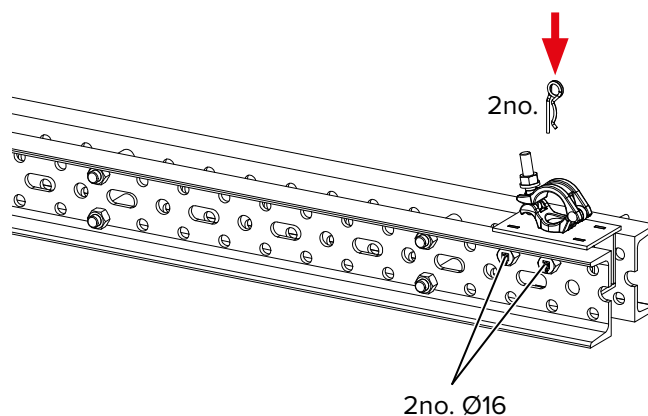

11.1.2 Attaching the IK Scaffold Tube Adapter to an IK Waler M

Components needed:

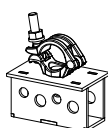

1no. IK Scaffold Tube Adapter
(code:608495)

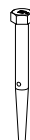

2no. IK Pins $\varnothing 20$
(code:608820)



2no. Spring Cotter Pins 4
(code:173776)

- Step 1** Insert the IK Scaffold Tube Adapter into an IK Waler M and fasten to the top row of holes with 2no. IK Pins Ø20. Secure the IK Pins with the Spring Cotter Pins.

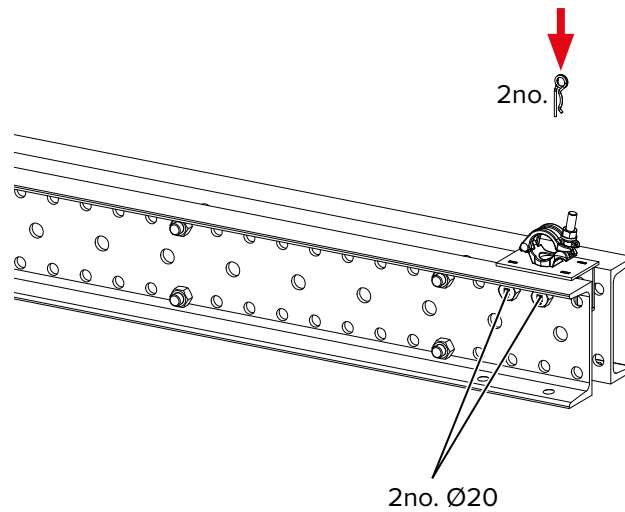

11.2 Attaching the Half Coupler to flange bores (only IK Walers M)

Scaffold tubes (Ø48.3 mm) can be attached to the flange bores of IK Walers M using the Half Coupler 48/M20 × 70. The wedge-shaped washer supplied with the equipment compensates for the diagonal underside of the flange.

Components needed:



1no. Half Coupler 48/M20 × 70
(code:608515)

- Step 1** Secure the half coupler (C) with the wedge-shaped washer (B) and the nyloc nut (w.a.f. 22) (A). The thicker side of the washer should face out.

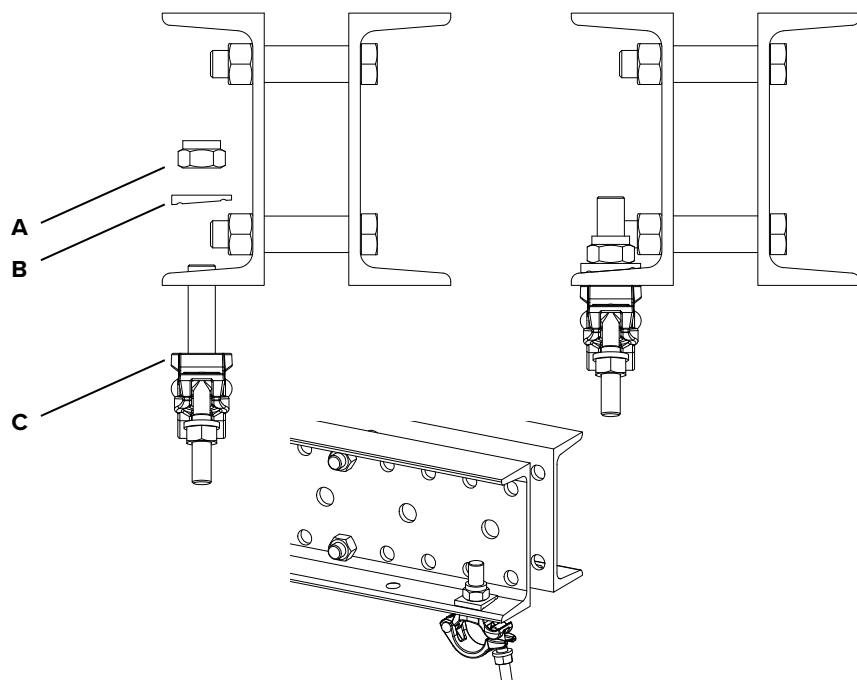

11.3 Bracing IK Walers

The following example shows how to brace walers using an IK Scaffold Tube Adapter. The procedure is the same for the Half Coupler 48/M20 × 70.

Step 1 Open the coupler on the IK Scaffold Tube Adapter L/M.

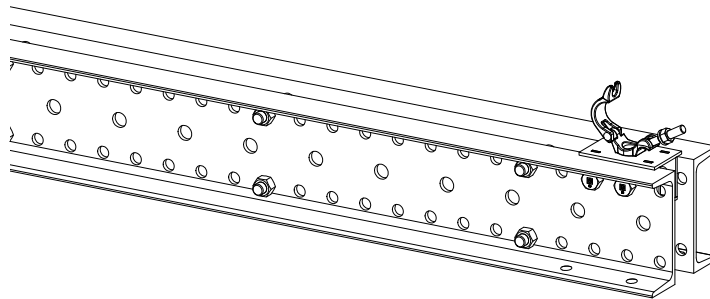

Step 2 Place any scaffold tube in the coupler, close the coupler and tighten the nut on the coupler (50 Nm).

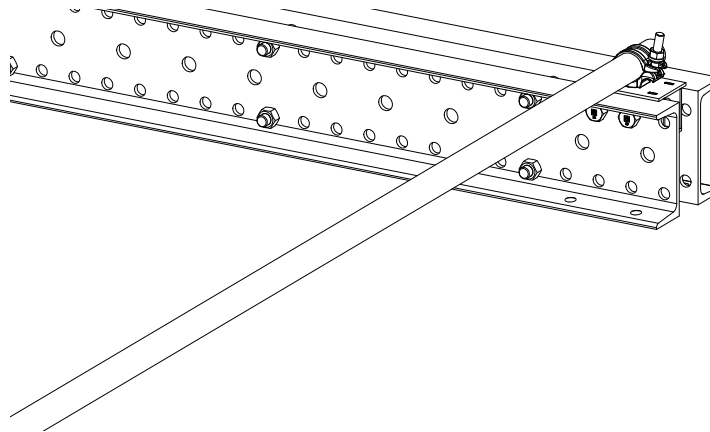

12 Edge protection

As specified in BS EN 13374 Temporary Edge Protection Systems, the minimum height between the working area and the top of the edge protection should be 1.00 m. This may vary if the top of the slab is to be considered as the working area instead of the top of the formwork panel, which will depend on how close the slab end is to the edge of the panel.

Height of edge protection

In accordance with BS EN 13374 Temporary Edge Protection Systems, the height of the edge protection should be determined as follows:

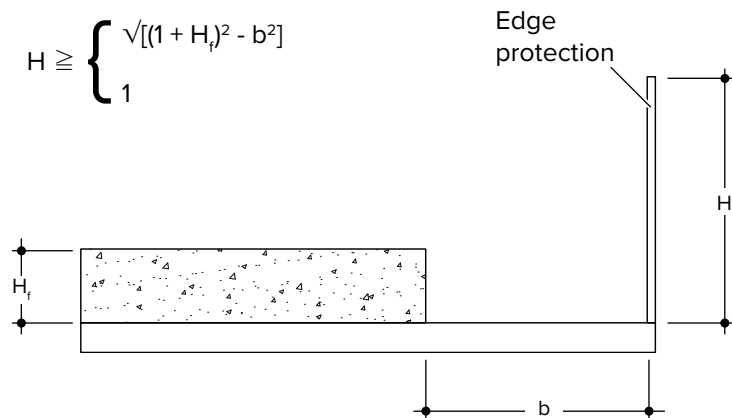

The value of the height (H) determined by the formula above should be the highest of the two values.

As a reference, the below table shows the required edge protection height (H) when both the slab height (H_1) and access width (b) are considered.

		Access width, b [m]									
		0.20	0.30	0.40	0.50	0.60	0.70	0.80	0.90	1.00	1.10
Level change, H_1 [m]	0.10	1.08	1.06	1.02	1.00	1.00	1.00	1.00	1.00	1.00	1.00
	0.15	1.13	1.11	1.08	1.04	1.00	1.00	1.00	1.00	1.00	1.00
	0.20	1.18	1.16	1.13	1.09	1.04	1.00	1.00	1.00	1.00	1.00
	0.25	1.23	1.21	1.18	1.15	1.10	1.04	1.00	1.00	1.00	1.00
	0.30	1.28	1.26	1.24	1.20	1.15	1.10	1.02	1.00	1.00	1.00
	0.40	1.39	1.37	1.34	1.31	1.26	1.21	1.15	1.07	1.00	1.00
	0.50	1.49	1.47	1.45	1.41	1.37	1.33	1.27	1.20	1.12	1.02

Values in white cell: BS EN 13374, minimum protection height 1.00m.

Values in shaded cell: PROTECTO posts with PROTECTO Panel G2 or with timber railing. Provide protection to BS EN 13374.

Values in shaded cells and in bold:

PROTECTO posts with PROTECTO Panels G2 or with timber railings as standard do not provide enough protection height. The access width may need to be increased, or the PROTECTO posts used with appropriate extension socket (requires reduced post spacing) or secondary edge protection on the slab to be installed.

However, if the height of the slab is such that it becomes a fall hazard, then a secondary edge protection is required regardless of the distance between the slab edge and the formwork edge. The height of this secondary edge protection must be 1.00 m

measured from the top of the slab.

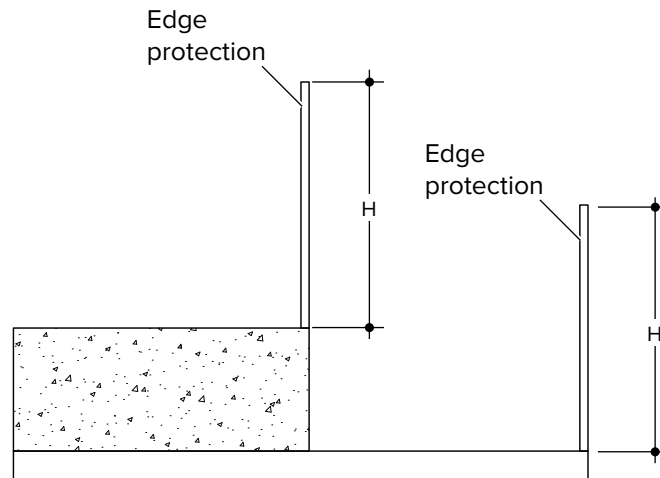

Although these are some of the most common cases used on site, other solutions which comply with the current standard may be used depending on the individual job requirements.



The minimum height of the edge protection may vary from region to region. In Germany for example, the minimum height of the edge protection will change from 1.00 m to 1.10 m if the drop height is more than 12.00 m.

Refer to your local regulation for more information.



WARNING

Risk of fall from height!

Suitable protective measures must be in place during the installation of the edge protection systems. It is assumed that the operatives are protected by these measures during assembly and disassembly of the edge protection systems.

The performance of an edge protection system is directly related to the structure to which it is attached. The structure must withstand the extra imposed loads.



WARNING

Risk of collapse and fall from height!

All fixings of the edge protection system to the existing structure must suit the specific application and be selected by a competent person.

Customer to ensure that the concrete can take the extra imposed loads.

12.1 Panels and posts

12.1.1 Panels

The PROTECTO Panel G2 can be used for edge protection on both wet deck and dry deck applications. The PROTECTO Panel G2 is to be used with the PROTECTO posts and depending on the application the required ancillary components will vary.

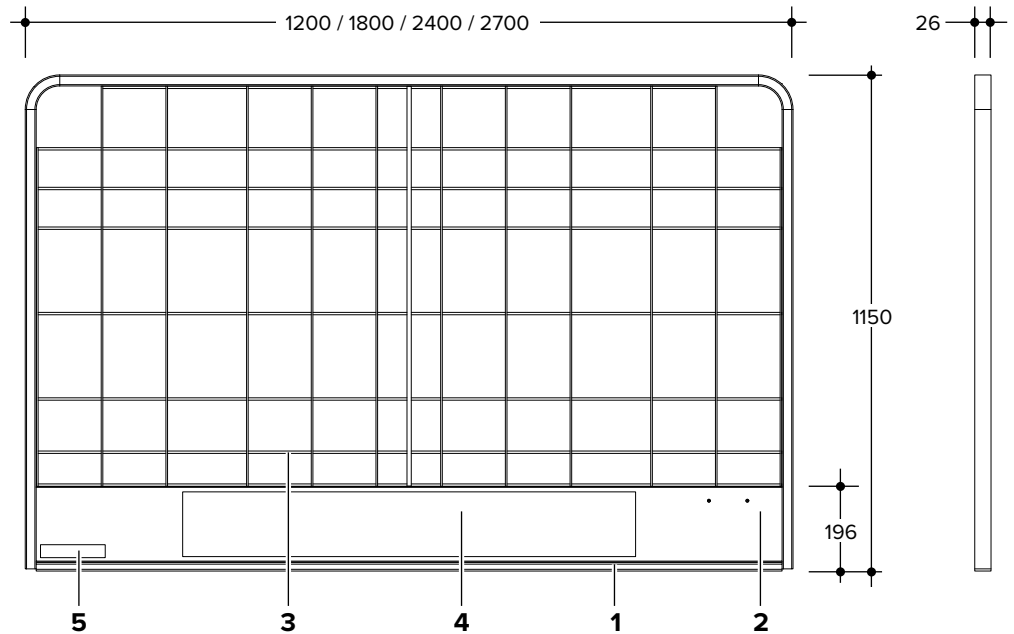

- 1 Steel frame
- 2 Steel toeboard
- 3 Steel wire $\text{Ø}5.5$ mm (horizontal) $\text{Ø}3.75$ mm (vertical)
- 4 Centre sticker (company branding)
- 5 Small sticker (item information)

The minimum required panel overlap is 200 mm as shown below.

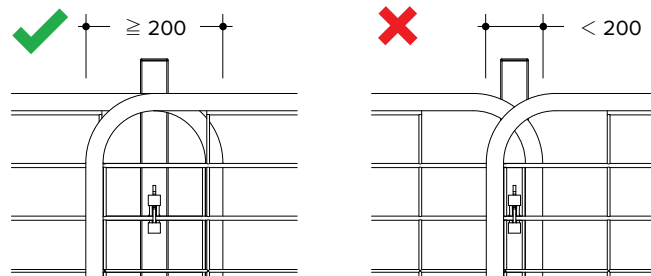

12.1.2 Posts

PROTECTO Post 130 Adjustable

The PROTECTO Post 130 Adjustable (code:692750) provides support for the PROTECTO Panels G2. The post has a cross-section of 35 x 35 mm which allows the PROTECTO Post 130 Adjustable (code:692750) to be used with the ancillaries of the PROTECTO Railing Post (code:601225).

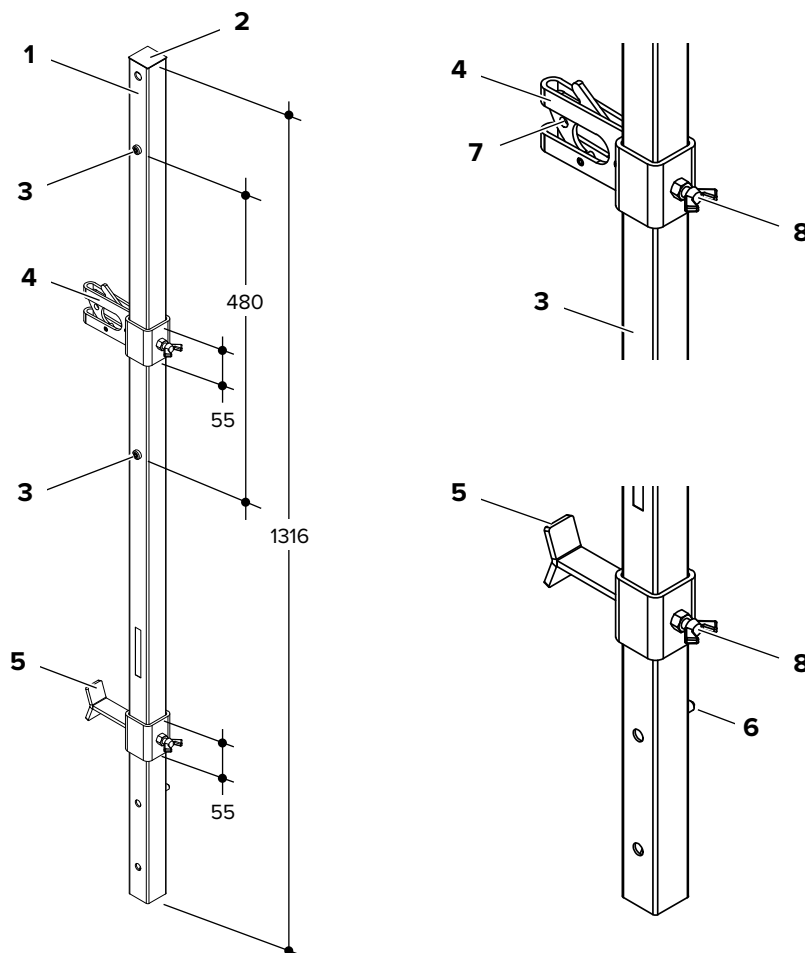

- 1 SHS 35 x 35 x 2 mm
- 2 Plastic cap
- 3 Tapping screw as Ø12 mm stopper
- 4 Sliding latch
- 5 Sliding T latch
- 6 Safety device (not visible) - see page 103
- 7 Ø8 mm hole for plastic zip tie
- 8 Captive hexagonal nut and wing nut



It is recommend that the sliding latch is secured against accidental opening by using a plastic zip tie through the Ø8 mm hole.

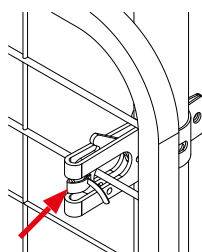

For additional security, a cable tie can be added (optional).

PROTECTO Railing Post

The PROTECTO Railing Post (code:601225) can be used with the PROTECTO Panels G2 and the timber railing as an option for edge protection.

It is equipped with 2no. brackets for plank railings with dimensions of 150×30 mm. The post is secured by correctly inserting the integrated safety lock.

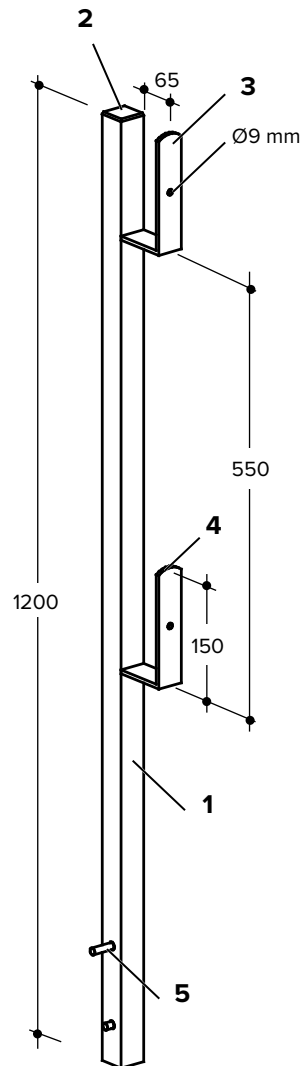

- 1 RHS 35 x 35 x 2 mm
- 2 Plastic cap
- 3 Top bracket
- 4 Bottom bracket
- 5 Safety device - see page 103

The PROTECTO Railing Post (code:601225) complies with BS EN 13374 when used with the PROTECTO Panels G2 and with plank railings. The planks used for railing must be 30 mm thick, 150 mm high and meet the requirements of strength class C24 according to EN 338 (formerly S10).

Safety device

The safety device is used to prevent accidental displacement of the PROTECTO posts. Both the PROTECTO Post 130 Adjustable (code:692750) and the PROTECTO Railing Post (code:601225) have a safety device.

To correctly install the PROTECTO posts, insert the post into the retainer and press the actuator pin of the safety lock. The locking pin retracts inside the post and the post can be inserted into the retainer. When the locking pin is inside the retainer piece, release the actuator pin. Insert the post into the retainer until the spring mechanism can be heard and seen as fully locked. Test the proper seating of the post by pulling and inspect visually the correct engagement of the locking pin.

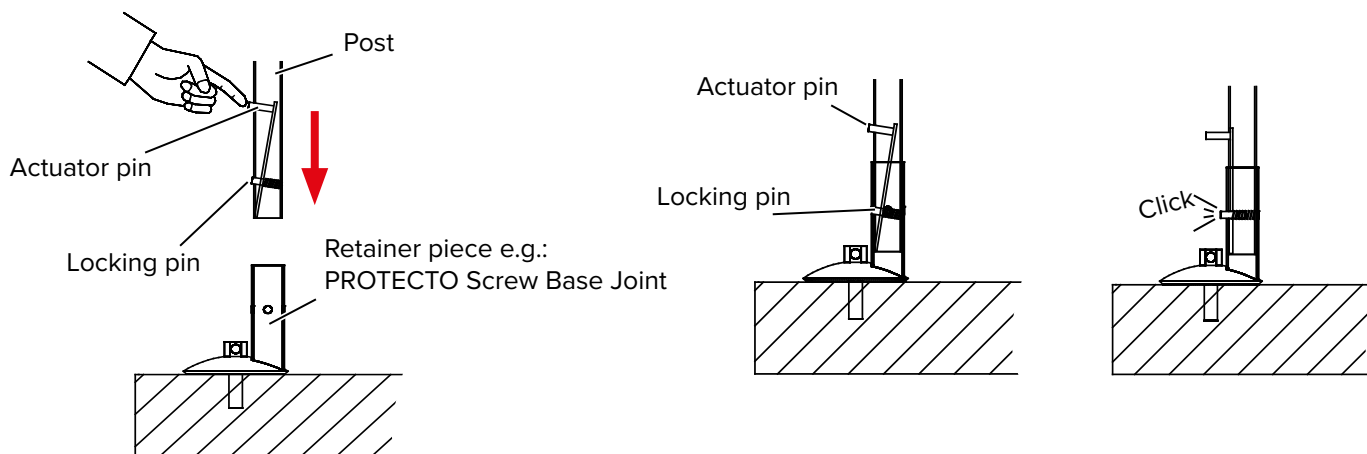

 WARNING	<p>Risk of falling from height! Do not use a post with a damaged or missing safety device.</p>
--	---

	<p>Ensure that the locking pin is properly engaged to the retainer piece.</p>
---	---

12.1.3 Toeboard retainer

The PROTECTO Toeboard Retainer (code:601227) is used in conjunction with the PROTECTO Railing Post (code:601225) to allow for a timber plank to be used as a toeboard. No tools are required to install the PROTECTO Toeboard Retainer (code:601227).

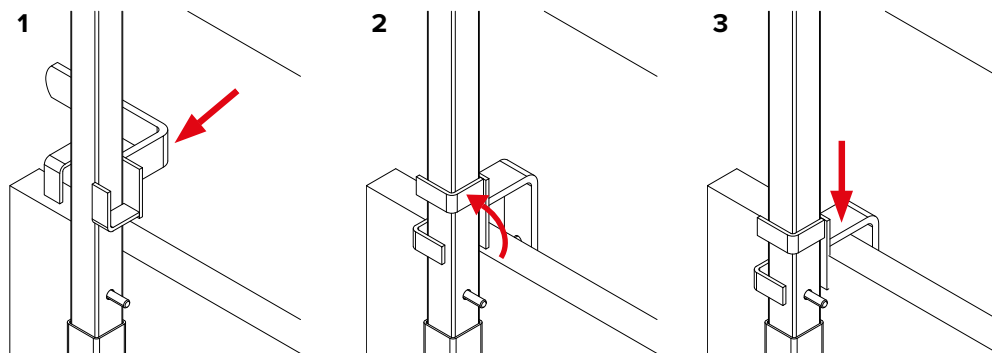

12.2 Constructing edge protection with PROTECTO Post 130 Adjustable

Use the IK PROTECTO Adapter to attach the PROTECTO Post 130 Adjustable to IK Walers L and M. Complete edge protection can be erected with the aid of the PROTECTO Panel G2.

It is also possible to erect edge protection with components from the MODEX system. Use the IK MODEX Adapter to attach MODEX Vertical Posts to IK Walers.



Use of PROTECTO and MODEX components is described in the respective user guide. Always comply with the instructions in the user guide to ensure safe erection and use!

12.2.1 Setting the angle of the IK PROTECTO Adapter

The IK PROTECTO Adapter has a swivelling sleeve for the PROTECTO Post 130 Adjustable. This means that the PROTECTO Post 130 Adjustable is always vertical, even when the IK Walers are inclined. Secure the position of the swivelling sleeve with 1no. IK Pin $\varnothing 16$.

The following illustration shows the setting range of the IK PROTECTO Adapter.

When the PROTECTO Adapter is used in an IK Waler M, the maximum achievable angle is 30°.

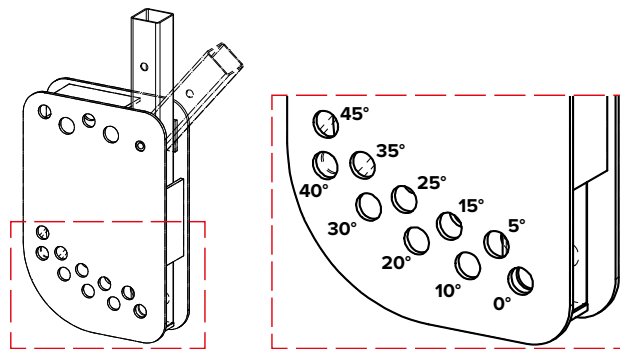

12.2.2 Attaching the IK PROTECTO Adapter

This section explains how to attach the IK PROTECTO Adapter to IK Walers L. The procedure is the same for IK Walers M, except that IK Pins $\varnothing 20$ are used instead.

Components needed:

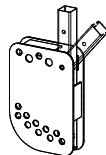

1no. IK PROTECTO Adapter
(code:608410)



3no. IK Pins $\varnothing 16$
(code:608816)



3no. Spring Cotter Pins 4
(code:173776)

or
2no. IK Pins $\varnothing 20$
(code:608820)
and
1no. IK Pin $\varnothing 16$
(code:608816)

Step 1 Slide the IK PROTECTO Adapter into the IK Waler and secure with 2no. IK Pins Ø16 (IK Waler L) or 2no. IK Pins Ø20 (IK Waler M). Secure the IK Pins with the Spring Cotter Pins.

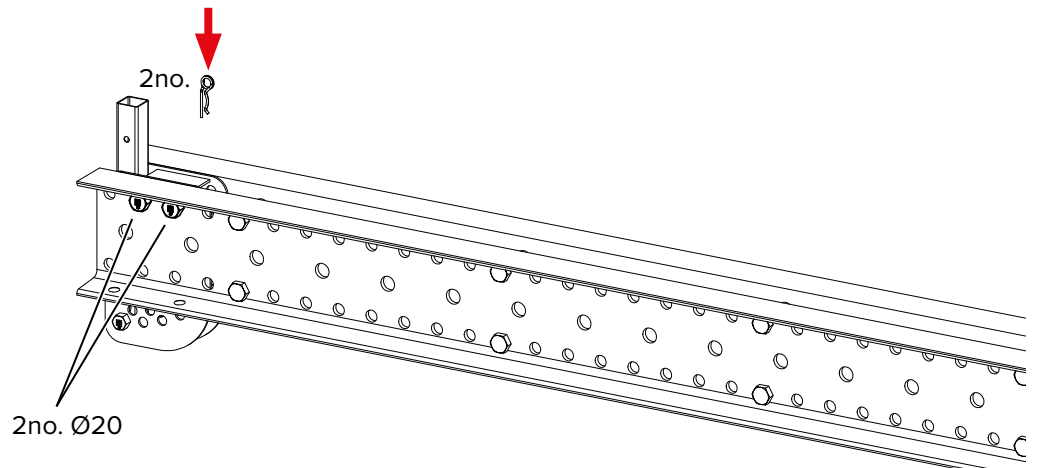
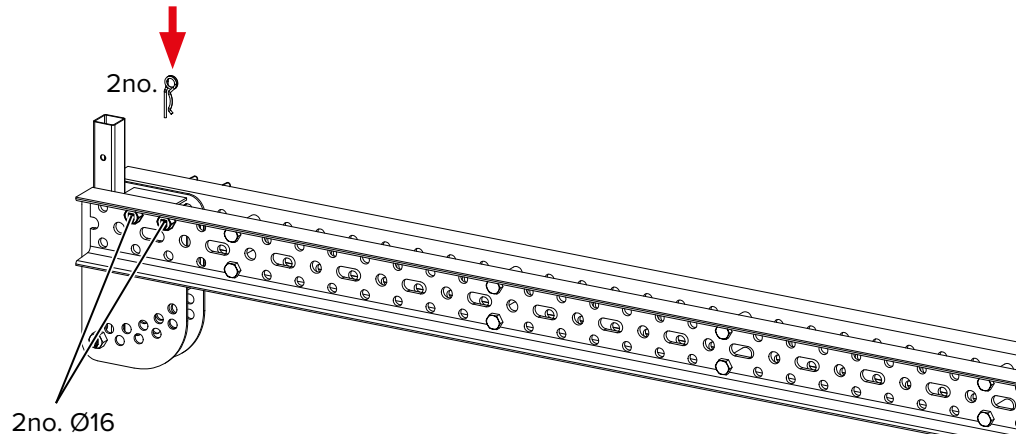

Step 2 Place the PROTECTO Post 130 Adjustable in the base for PROTECTO Posts.

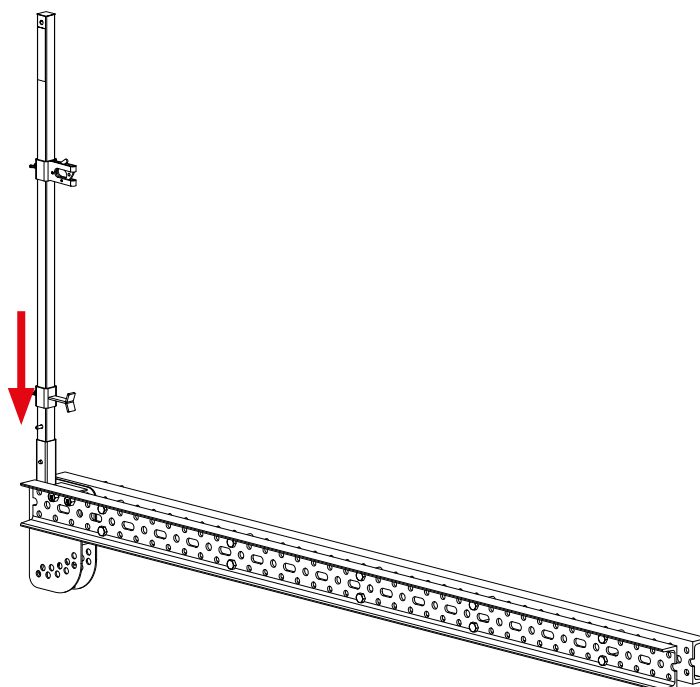

Step 3 Adjust the angle of the IK PROTECTO Adapter. Remove the adjusting pin (A, IK Pin Ø16) from the IK PROTECTO Adapter, tilt the PROTECTO Railing Post and insert the pin again in the suitable hole. Secure the Pin with a Spring Cotter Pin.

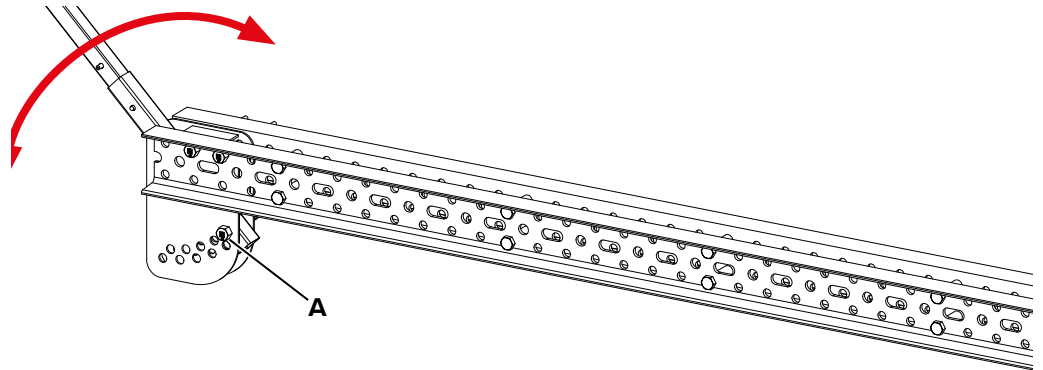

12.3 Constructing edge protection with MODEX



IK MODEX Adapters should be spaced no more than 2.50 m apart!

12.3.1 Attaching the IK MODEX Adapter to an IK Waler L

Components needed:

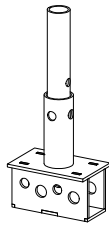

1no. IK MODEX Adapter
(code:608570)



2no. IK Pins Ø16
(code:608816)



2no. Spring Cotter Pins 4
(code:173776)

Step 1 Insert the IK Scaffold Tube Adapter into an IK Waler L and fasten to the top row of holes with 2no. IK Pins Ø16. Secure the IK Pins with the Spring Cotter Pins.

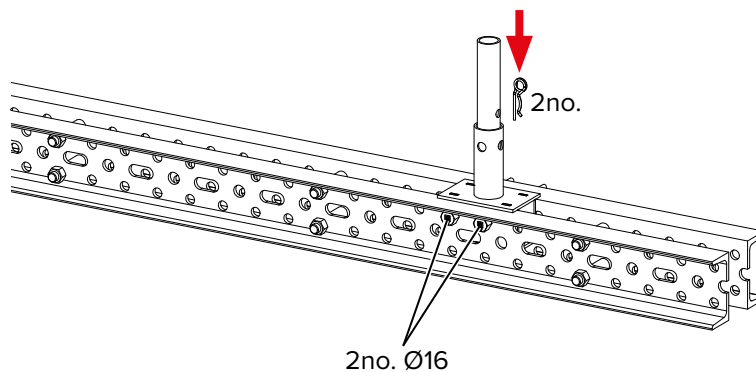

12.3.2 Attaching the IK MODEX Adapter to an IK Waler M

Components needed:

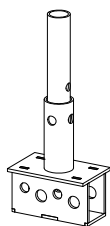

1no. IK MODEX Adapter
(code:608570)



2no. IK Pins Ø20
(code:608820)



2no. Spring Cotter Pins 4
(code:173776)

Step 1 Insert the IK Scaffold Tube Adapter into an IK Waler M and fasten to the top row of holes with 2no. IK Pins Ø20. Secure the IK Pins with the Spring Cotter Pins.

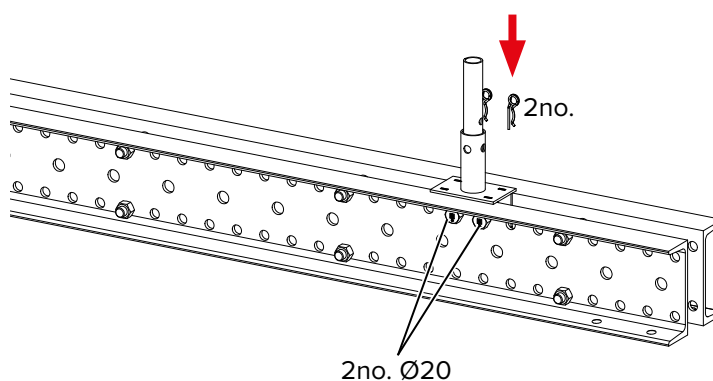

12.3.3 Example of assembled MODEX edge protection

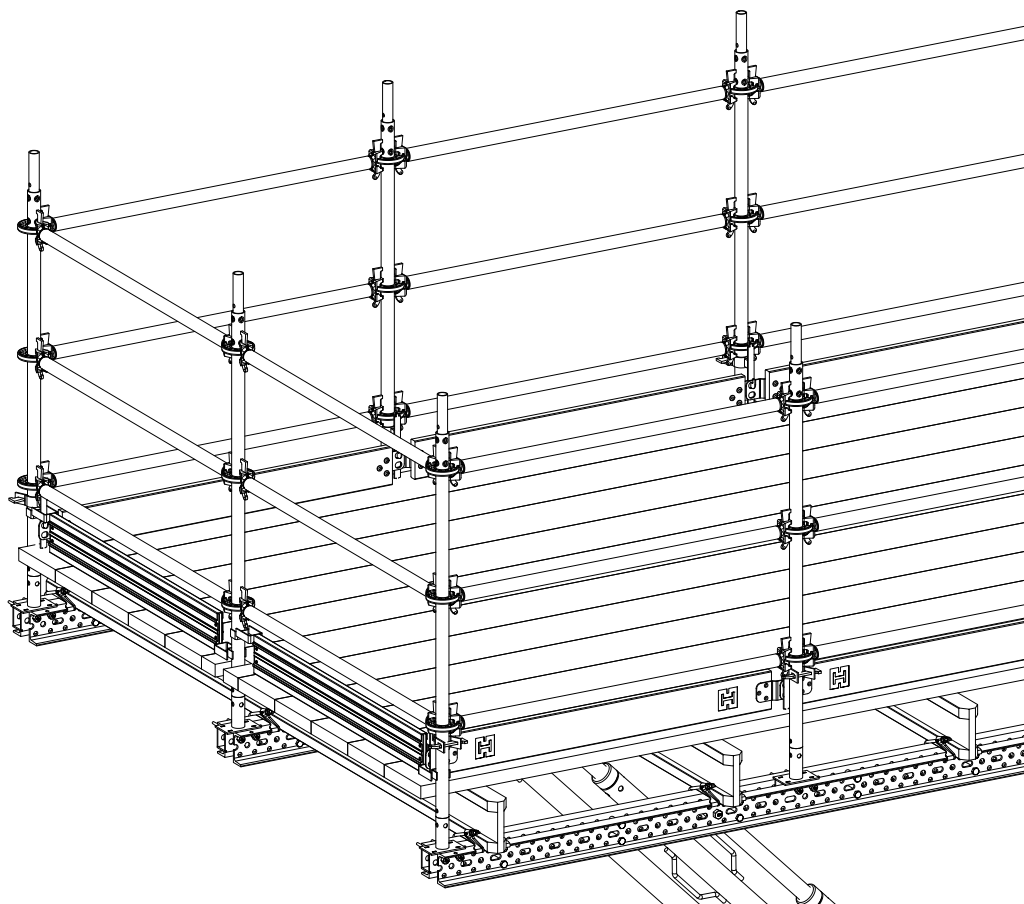

13 Assembly of INFRA-KIT H

13.1 Recommended sequence for horizontal assembly and transport

13.1.1 Preparations

Step 1 Prepare a suitable assembly area (framing ground) The ground has to be level, well compacted, capable of withstanding the loads and accessible for a forklift or crane.

Step 2 Place squared timbers or H 20 beams as spacers on the ground in the assembly area.



To simplify assembly later, arrange the spacers (squared timber or H 20 beams) to accommodate the Main Beams and the components to be connected.

13.1.2 Main Beams

Step 1 Remove the Connecting Pins from the Main Beams and place the Main Beams into assembly position on squared timbers or H 20 beams.

Step 2 Align the Main Beams and insert the Connecting Pins. Secure the Connecting Pins with lynch pins.

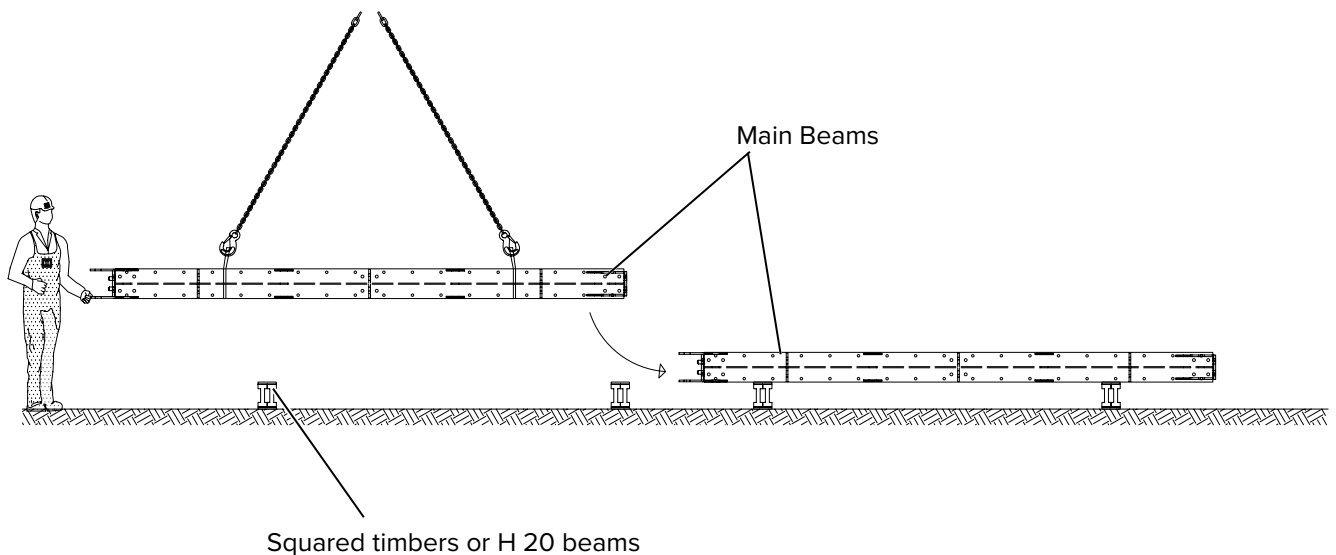

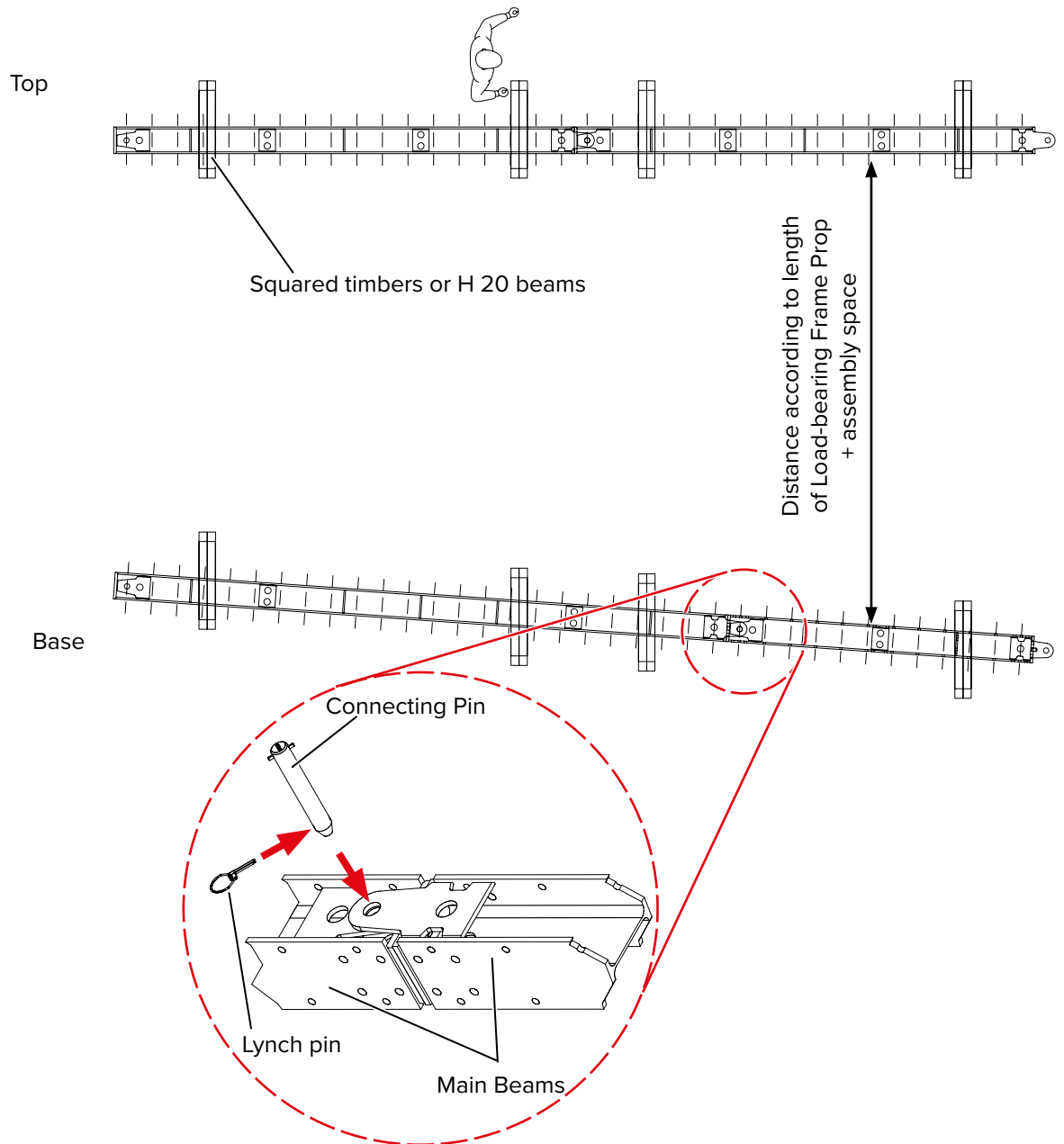

Step 3 Slide the Main Beams together and secure with the Connecting Pin.

Step 4 Secure the Connecting Pins with lynch pins. Lock the safety clip in the lynch pin.

13.1.3 Bracing underside

Step 1 Insert Tension Bolts.

Step 2 Insert the Tie Rods in the Tension Bolts on the underside of the diagonal bracing and secure with the lynch pins.

Step 3 Screw on the Tension Nut Set DW 15 by the base (do not tighten!).

Step 4 Counter the Tie Rod to the Tension Bolt at the top with Hexagon Nuts 15/50 to prevent twisting.

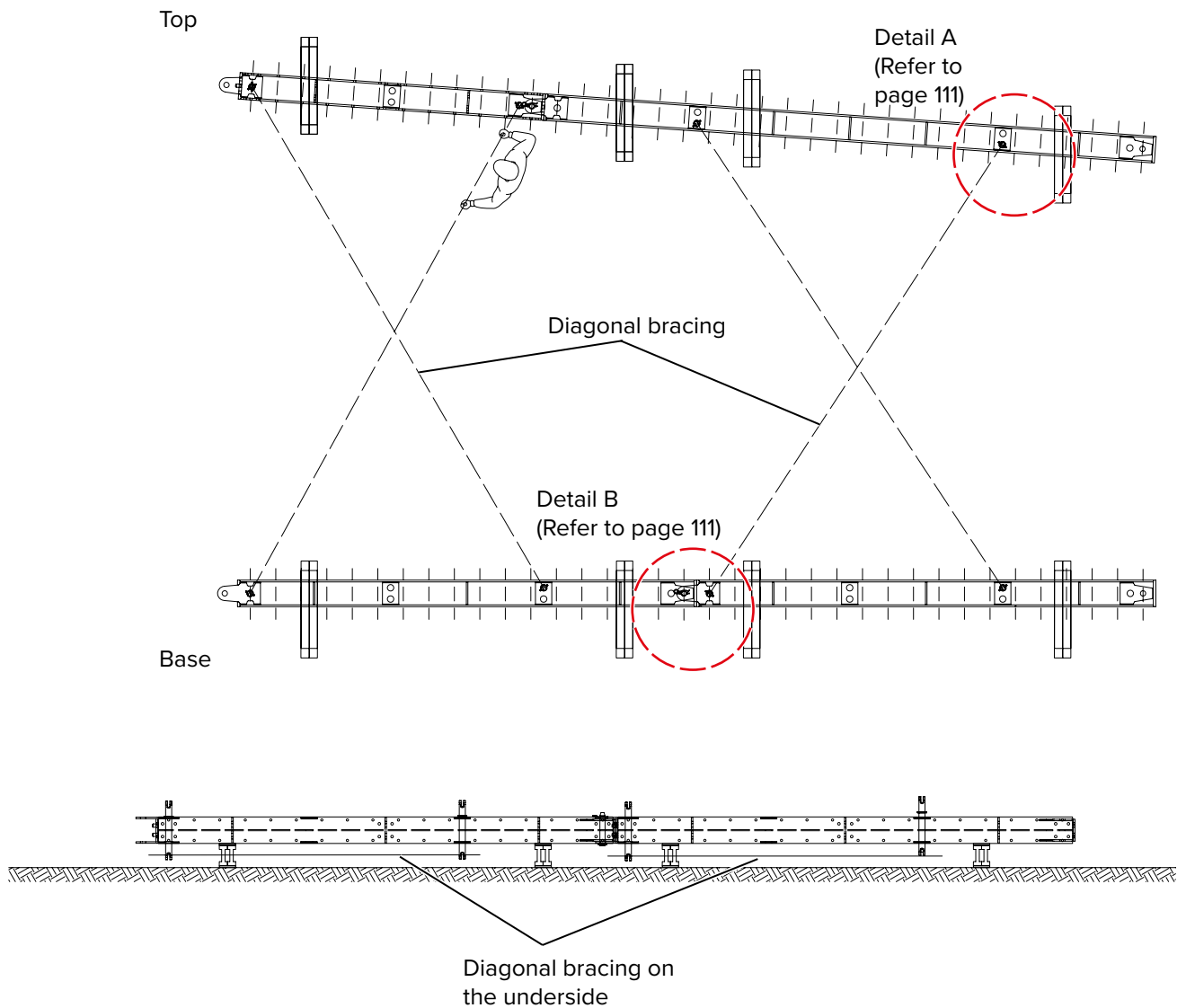

13.1.4 Installing Tie Rods

At the top with counter nuts – upper connection of diagonal bracing



WARNING

Warning!

Depending on the capacity of the Tension Bolt, the safe working load (SWL) is restricted to 40.50 kN per Tie Rod.

- Step 1** Remove one lynch pin from the Tension Bolt and insert the Tension Bolt into the Main Beam (Detail A, Fig. 1).
- Step 2** Screw a Hexagon Nut 15/50 onto the Tie Rod.
- Step 3** Slide the Washer 25 onto the Tie Rod and screw on the second Hexagon Nut 15/50 such that the nuts are on both sides of the Tension Bolt. The Washer 25 has to rest in the groove on the Tension Bolt.
- Step 4** Place the Tie Rod of the diagonal bracing laterally in the Tension Bolt and secure with the lynch pin (Detail A, Fig. 2).
- Step 5** Tighten the Hexagon Nuts 15/50 on both sides against the Tension Bolt to prevent the Tie Rod from twisting.

Detail A, Figure 1

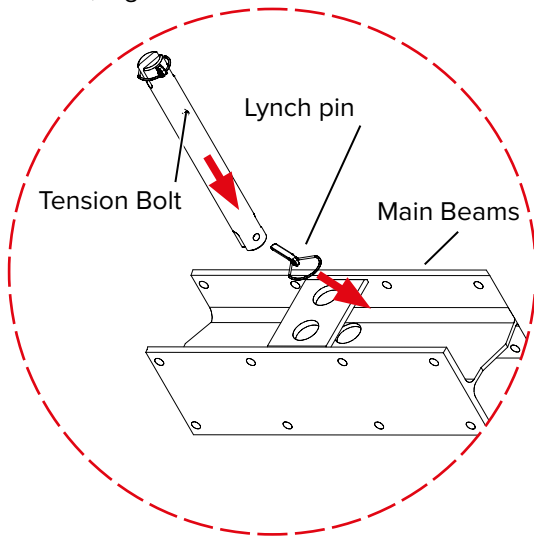

Detail A, Figure 2

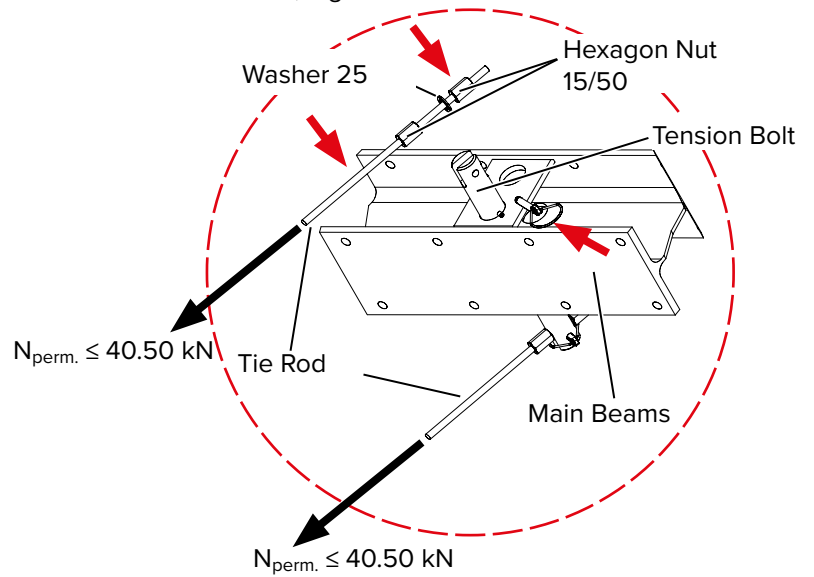

At the base with Tension Nut Set

- Step 1** Remove the lynch pin from the Tension Bolt and insert the Tension Bolt into the Main Beam (Detail B, Fig. 3).
- Step 2** Screw a Hexagon Nut 15/50 onto the Tie Rod.
- Step 3** Slide on Washer 25 and screw on the preload nut.
- Step 4** The Washer 25 has to rest in the groove on the Tension Bolt.
- Step 5** Place the Tie Rod of the diagonal laterally in the Tension Bolt and secure with the lynch pin (Detail B, Fig. 4).
- Step 6** Screw the preload nut hand-tight against the Tension Bolt.

Detail B, Figure 3

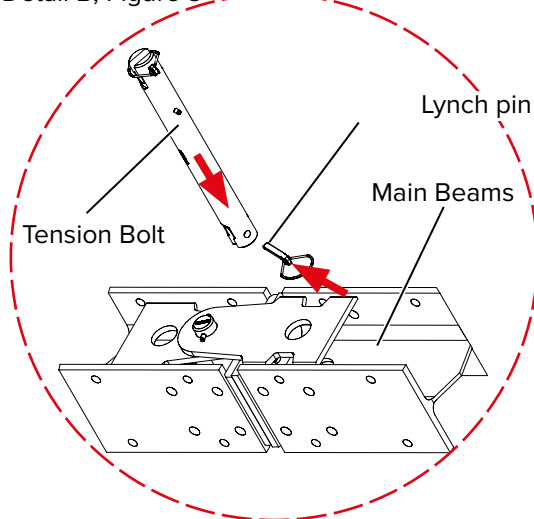

Detail B, Figure 4

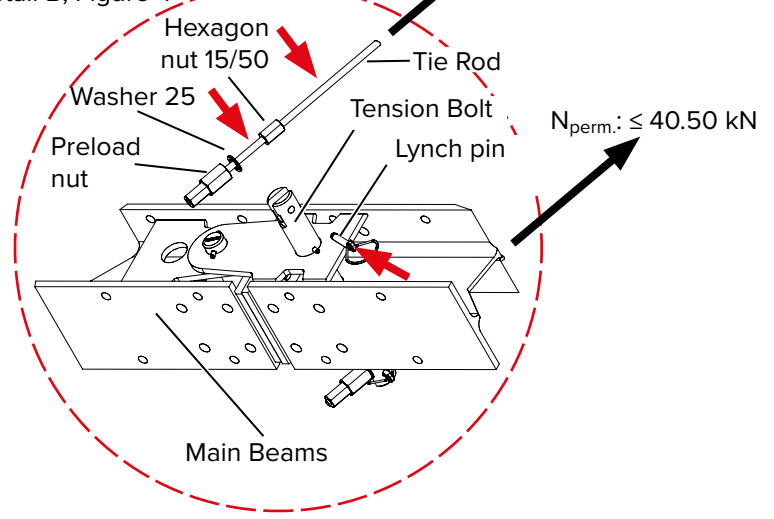

13.1.5 Installing the first and last Load-bearing Frame Prop

NOTE

Note

Scaffold tubes and couplers are intended only to provide stability during assembly and transport, not to be used as structural members of the final assembly!



If the Main Beams are intentionally not parallel to one another, we recommend horizontal assembly.

- Step 1** Check actual ground height on site.
- Step 2** Pre-assemble Load-bearing Frame Props to the correct length and pre-adjust the Spindles. Alternative: Install the Load-bearing Frame Props step by step.
- Step 3** Use the Load-bearing Frame Prop Set to connect the first and last Load-bearing Frame Prop to the Main Beam (Refer to details on page 114).
- Step 4** Ensure that the Main Beams are spaced properly at the top and base.
- Step 5** Construct an assembly of horizontal scaffold tubes and couplers on the underside of the Load-bearing Frame Props for temporary bracing.

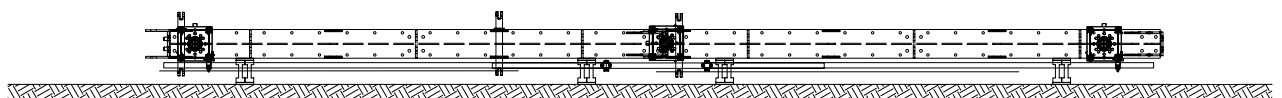
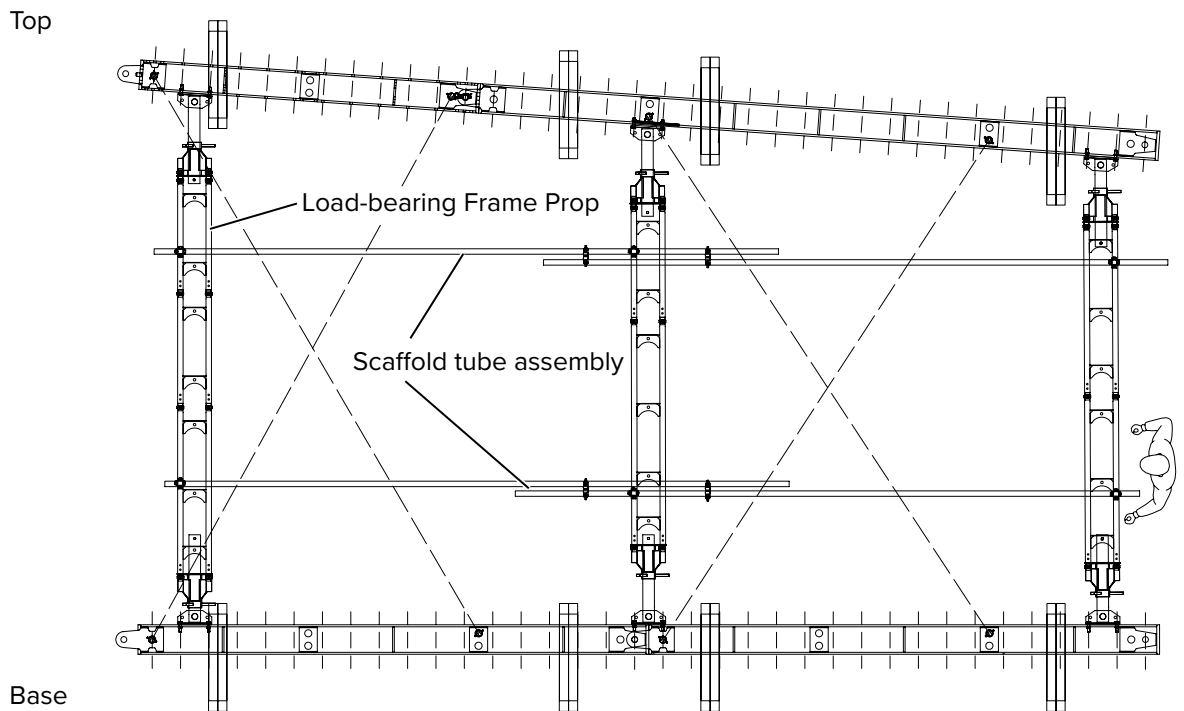

13.1.6 Middle Load-bearing Frame Props



To make the later fine adjustment of the vertical truss to the final height easier, it is advisable to initially leave 5 cm clearance when installing the middle Load-bearing Frame Props to the Head Jack.

- Step 1** Pre-assemble the middle Load-bearing Frame Props, extend the Spindles to the correct length, and extend the upper Spindles. Make the extension 5 cm shorter than the required length.
- Step 2** Attach the middle Load-bearing Frame Props to the Main Beams. Use the Load-bearing Frame Prop Bolt Set to attach the Spindles to the Main Beam at the base. Tighten the Bolts securely. Use the Bolt Set to attach the Spindles to the Main Beam at the top as well. Tighten the bolts securely. The 5 cm clearance remains in the prop due to the shorter Spindles.

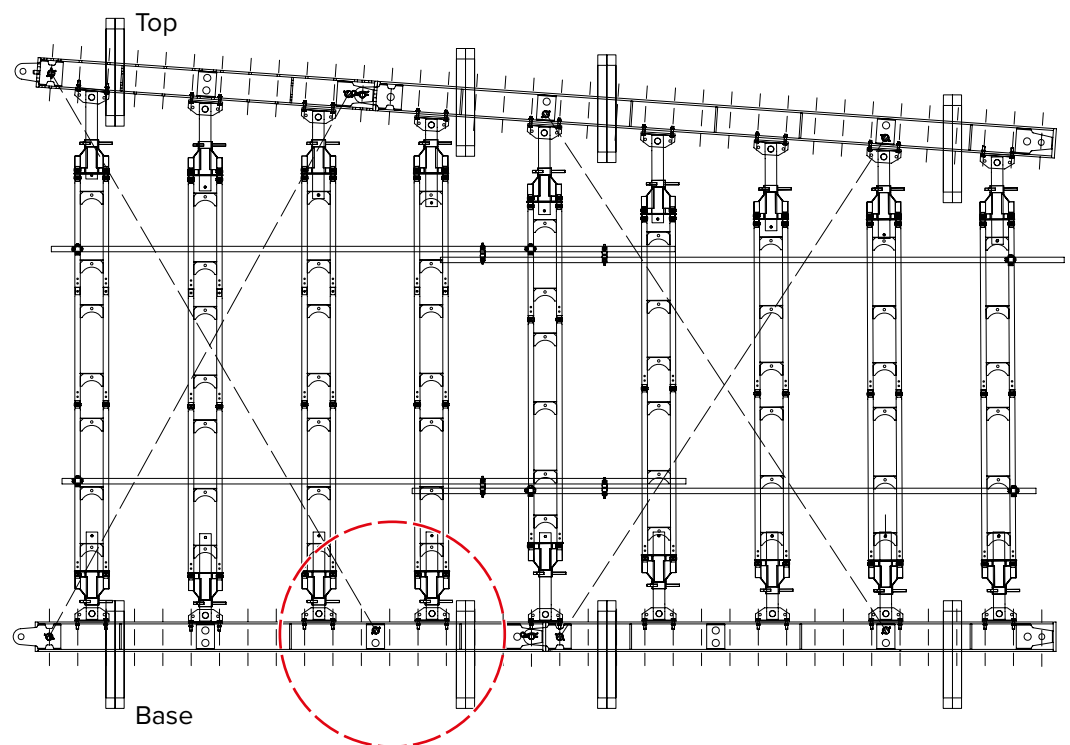

Assembly of INFRA-KIT H

Detail D
Case A Prop Jack

Case B Pin-jointed Base Plate

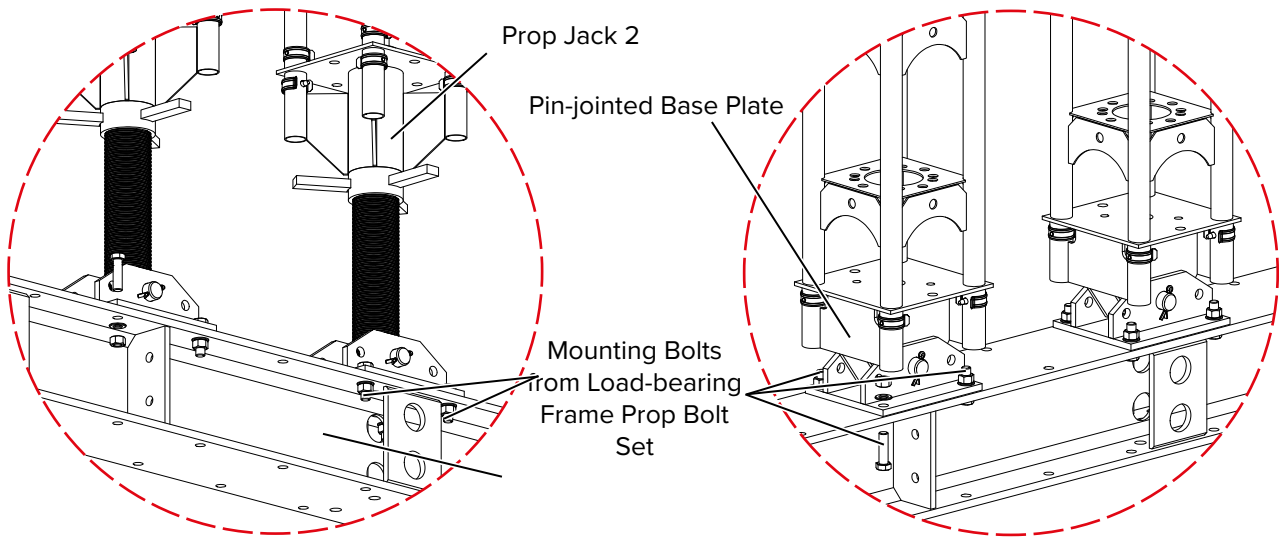

Use the Load-bearing Frame Prop Bolt Set to attach the Load-bearing Frame Prop to the Main Beam in both cases. The torque for M20 bolts can be found in the table on page 130.



WARNING

Warning!

Props not fixed with Bolts must be secured with Beam Clamps 16/70.

- Step 1** Use couplers to attach a diagonal scaffold tube assembly to the top side of the Load-bearing Frame Props.
- Step 2** Check that the diagonal bracing on top of the Load-bearing Frame Props is installed properly.
- Step 3** Place 2no. vertical Tie Rods on each side of the lifting unit to secure. Insert the vertical Tie Rods and tighten them with Tie Nuts at the top and base of the structure.
- Step 4** Attach the diagonal bracing to the top and tighten the Hexagon Nuts 15/15 against the Tension Bolt to prevent the Tie Rod from twisting.
- Step 5** Tighten the Tension Nut Set DW 15 without preload on the Tie Rod at the base of the structure (Refer to page 127).
- Step 6** Attach 2no. vertical Tie Rods for each pair of Main Beams.

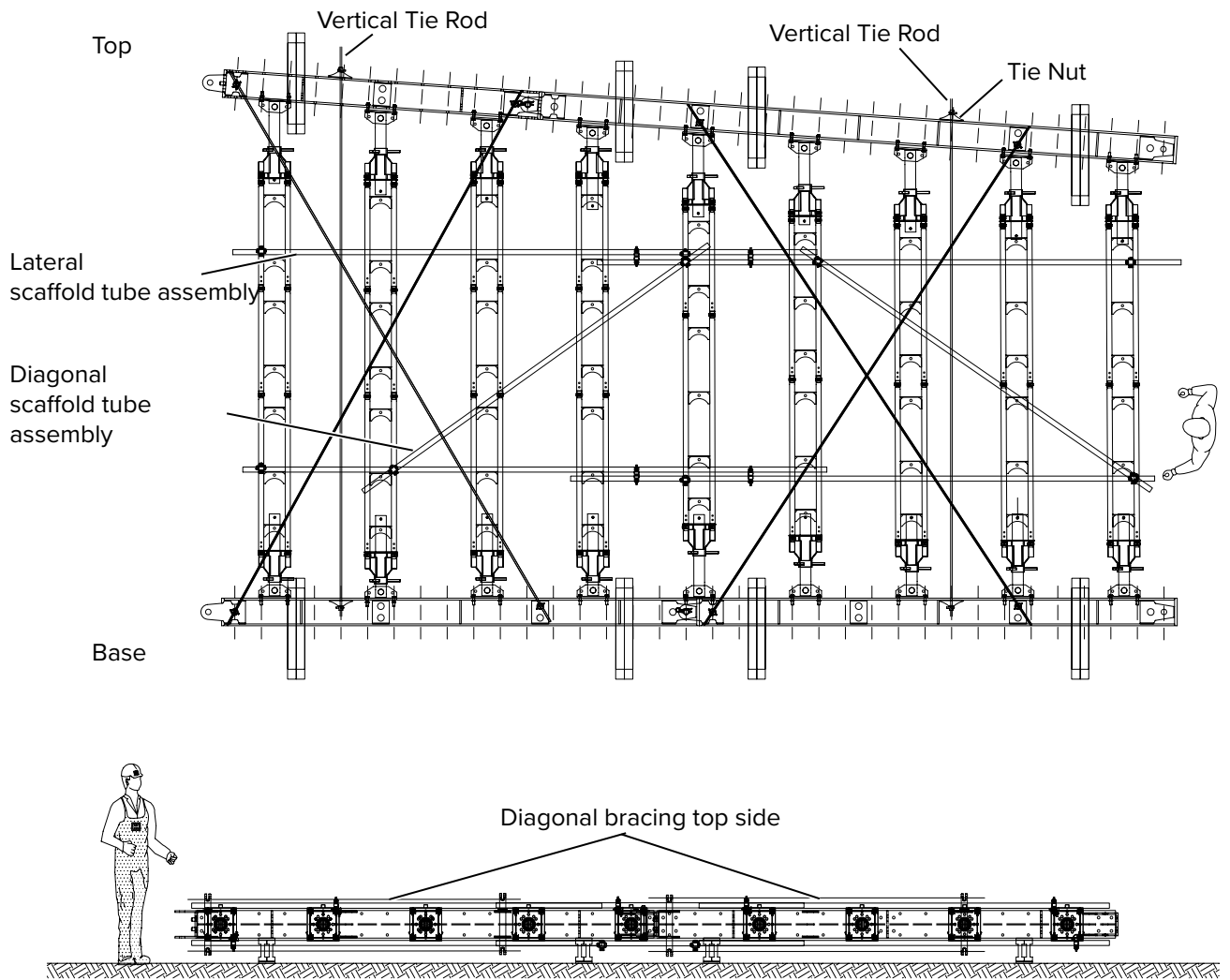

Step 7 If necessary, install walkways, planks, boards and Centring Bars 40/20.

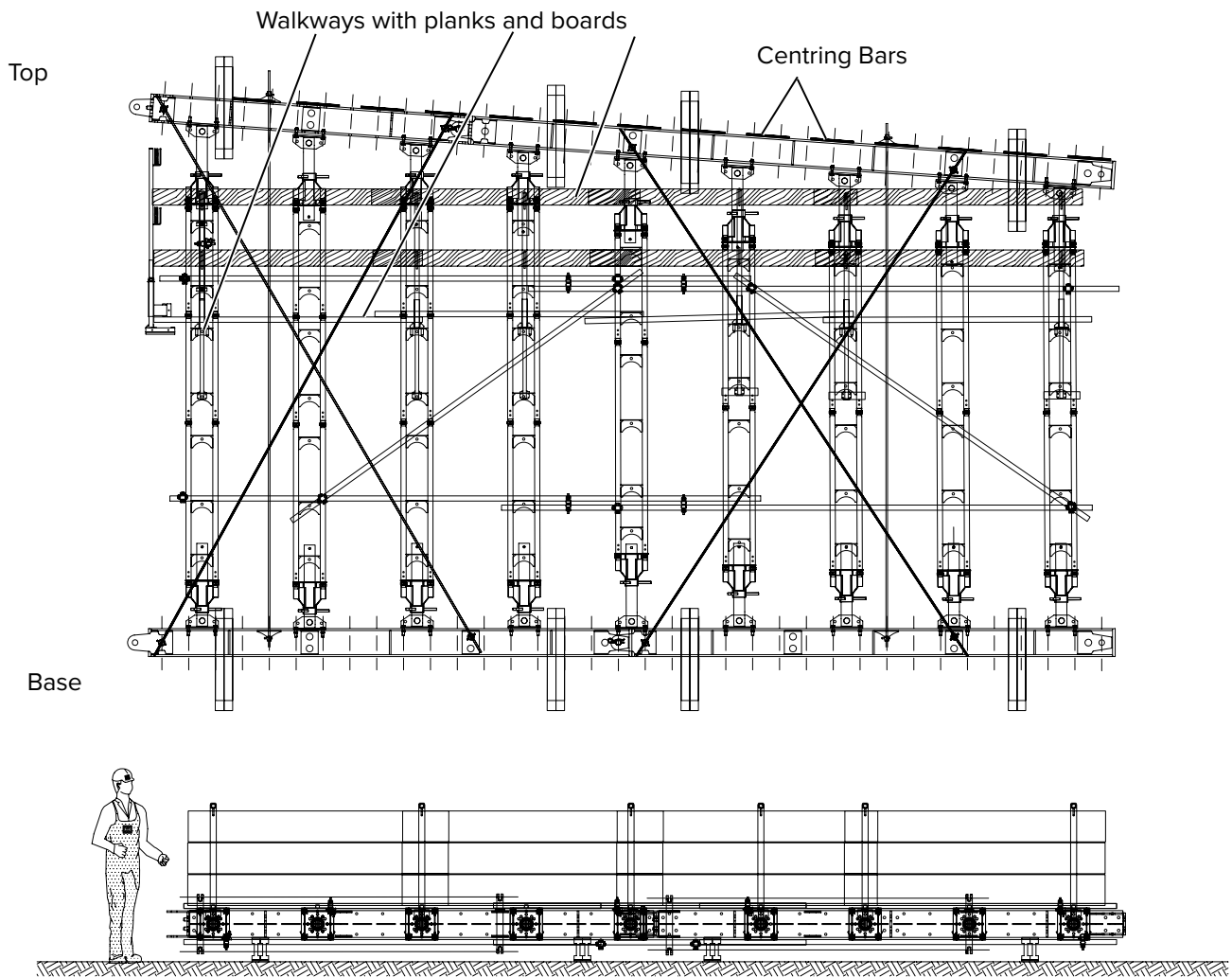

13.1.7 Preparing for tying for horizontal forces alongside abutment or pier

- Step 1** Prepare the assembly area. The ground has to be level, well compacted and able to withstand the required load. Ensure easy access for a forklift or crane.
- Step 2** Ensure safe access for mounting of Steel Walers and the Adjustable Abutment Bracket.
- Step 3** Attach the Steel Walers and the Adjustable Abutment Bracket to the abutment or bridge pier. Consult the design scheme for information on the number of Steel Walers and the location. Secure the points where the Steel Walers are tied to the structure to prevent them from being released unintentionally.

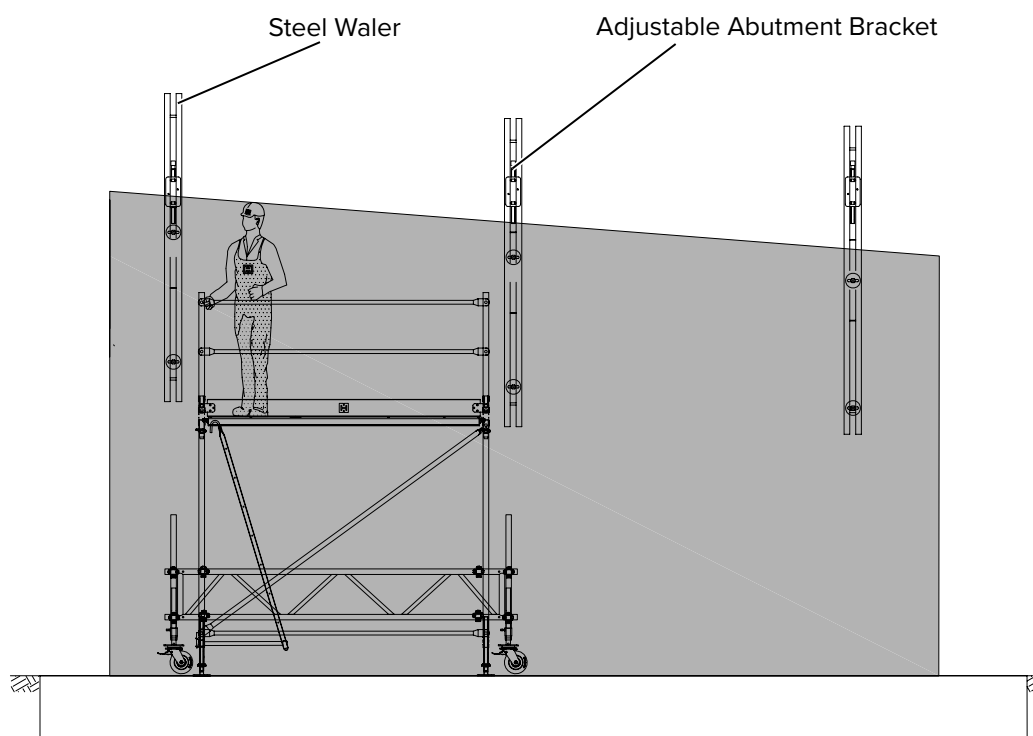

13.1.8 Raising and adjusting

Raising the pre-assembled module with suitable lifting equipment and positioning properly.

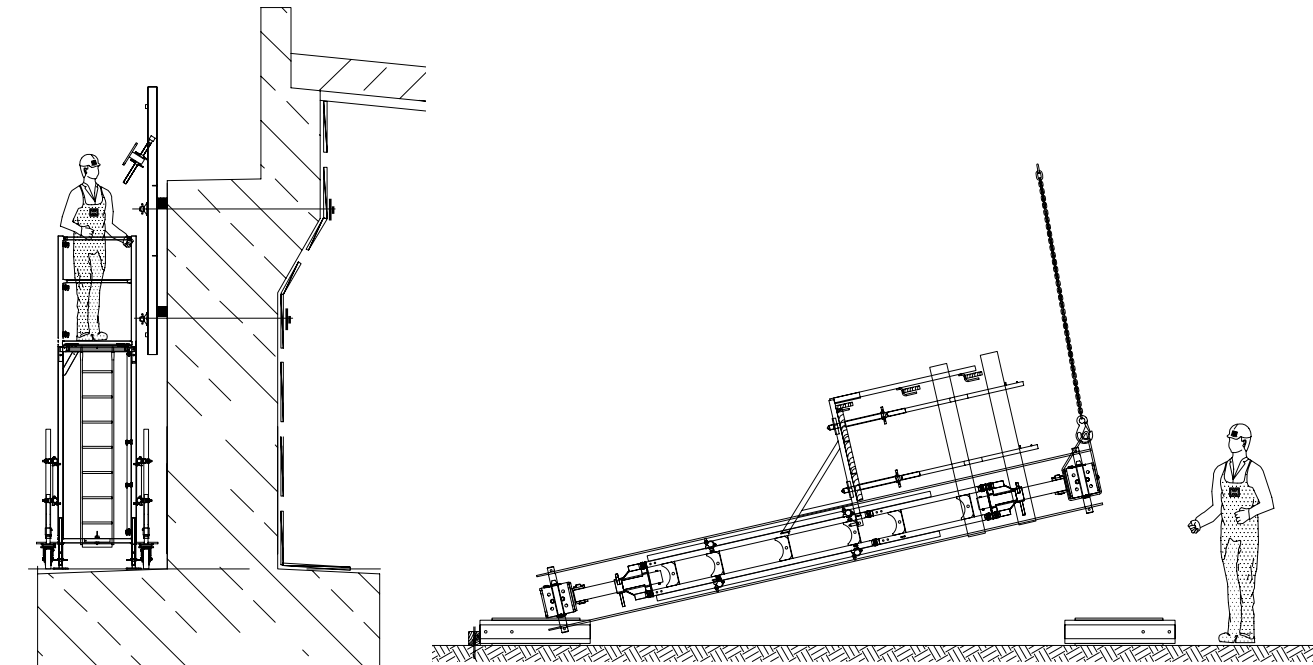

! WARNING

Warning!
The vertical truss has to rest on its full surface!
If necessary add padding materials (e.g. lean concrete).

! WARNING

Warning!
The Props have to be perpendicular to the ground! Deviation from vertical alignment may not be greater than 0.5 %.

NOTE

NOTE!

When preloading the Tie Rods DW 15, apply force step-by-step. Avoid different tensile forces in the Tie Rods to prevent damage and deflection.



When using multiple assemblies, a continuous connection of the Main Beams is recommended.

- Step 1** Use the Adjustable Abutment Bracket to attach the pre-assembled module to the existing structure (abutment) while it is still secured with the lifting device.

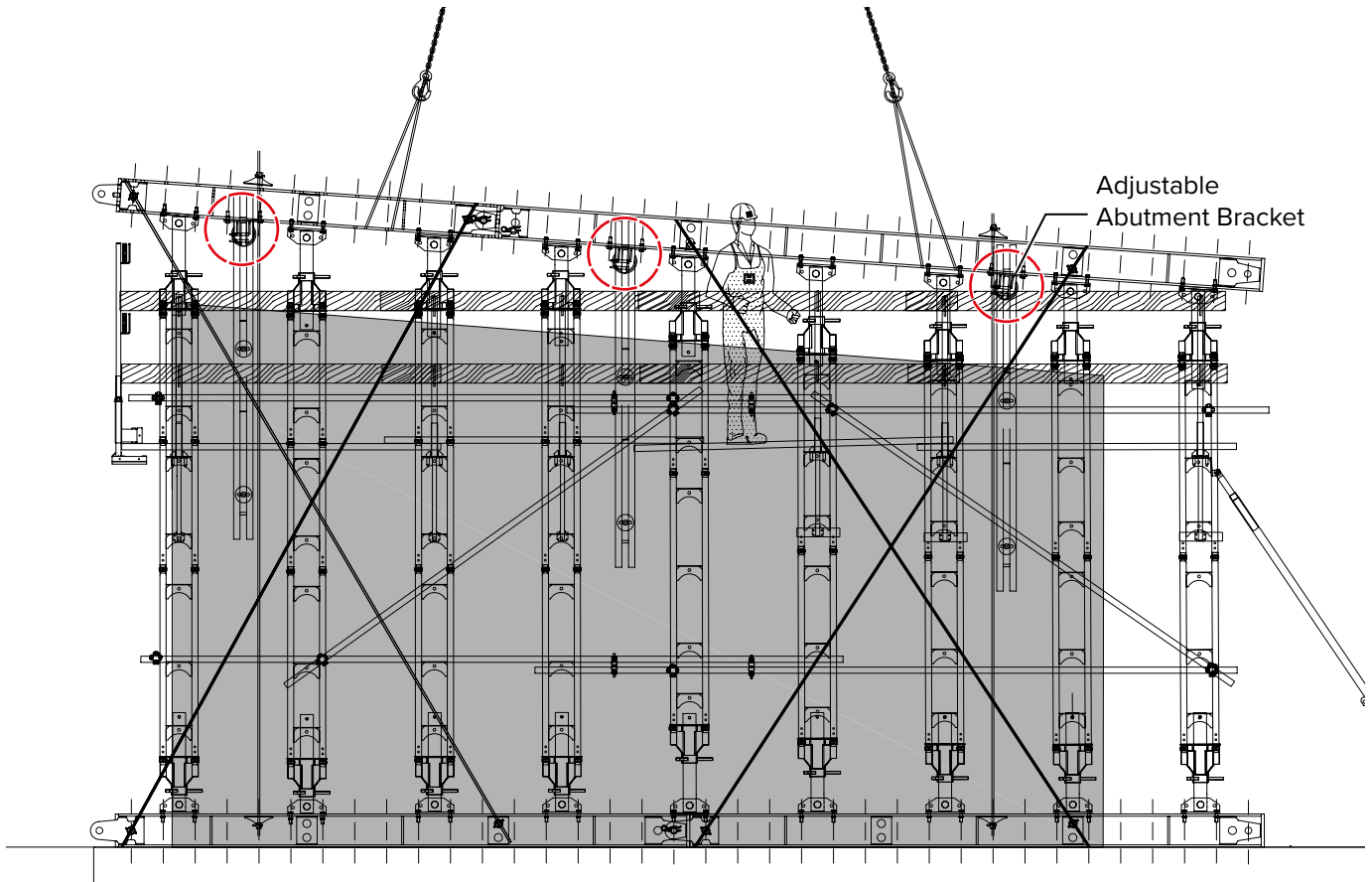

- Step 2** After releasing the pre-assembled module from the lifting device, align it with the Adjustable Abutment Bracket. Align the assembly vertically with the Adjustable Abutment Bracket.
- Step 3** Check if the Main Beam is at the right height in relation to the building and adjust if necessary. Adjust the Spindles at the outer Load-bearing Frame Props.
- Step 4** Retract the Spindles of the middle Load-bearing Frame Props to force-fit under the flange of the Main Beam and tighten the bolts in the head plate.
- Step 5** Align the pre-assembled modules lengthwise. Pre-tense the Tie Rods crosswise up to 10.00 kN by with the Tension Nut Set DW 15 (Refer to page 127).

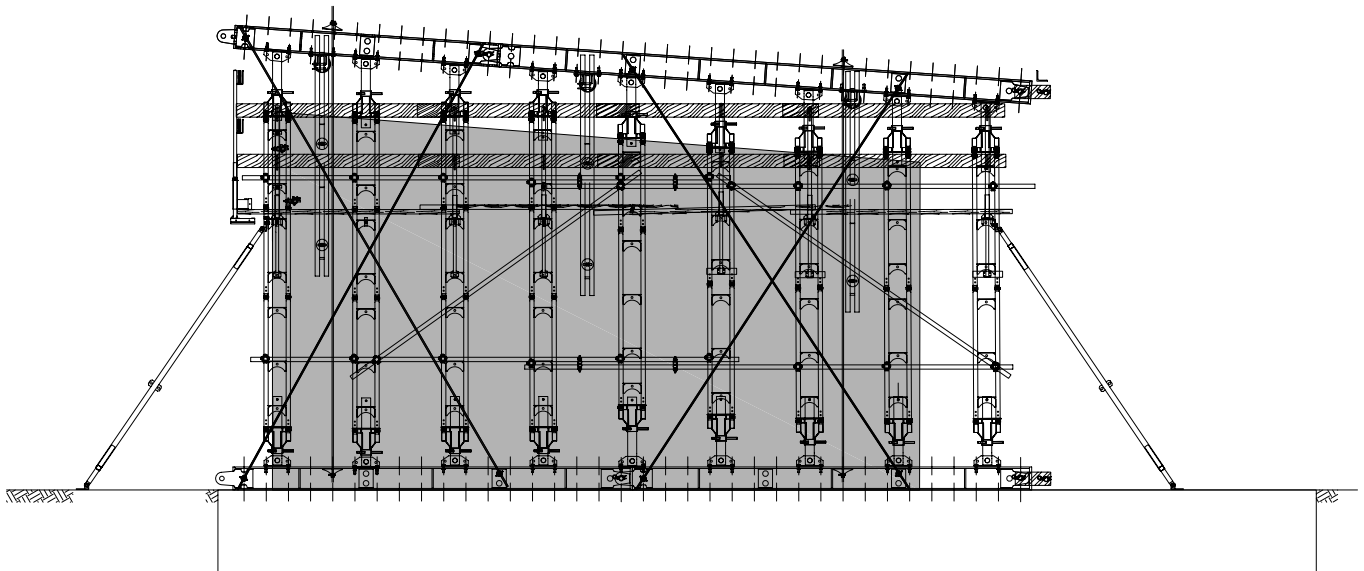
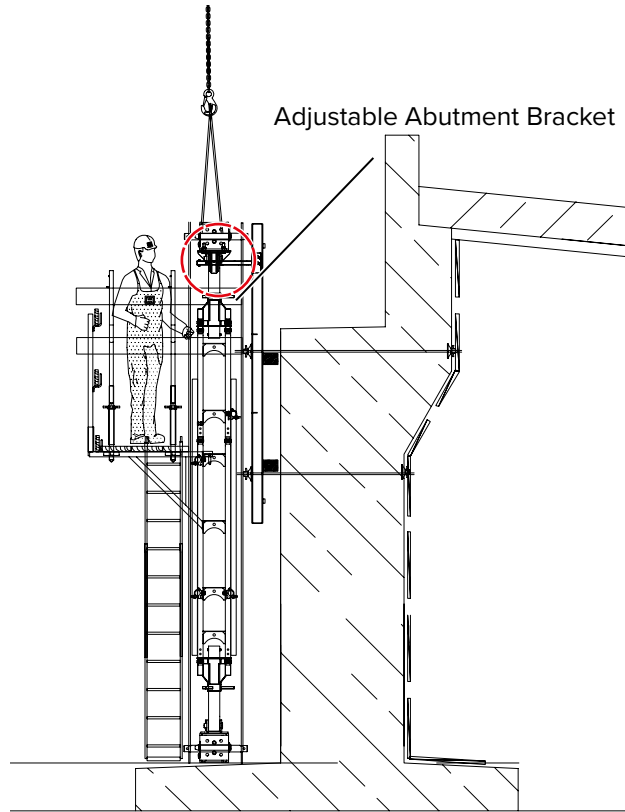

13.2 Recommended vertical assembly sequence on site

13.2.1 Preparations

- Step 1** Prepare the assembly area. The ground has to be level, well compacted and able to withstand the required load. Ensure easy access for a forklift or crane.
- Step 2** Ensure safe access for mounting of Steel Walers and the Adjustable Abutment Bracket.
- Step 3** Attach the Steel Walers and the Adjustable Abutment Bracket. Consult the design scheme for information on the number of Steel Walers and the location. Tie the Steel Walers such that they cannot be released unintentionally.

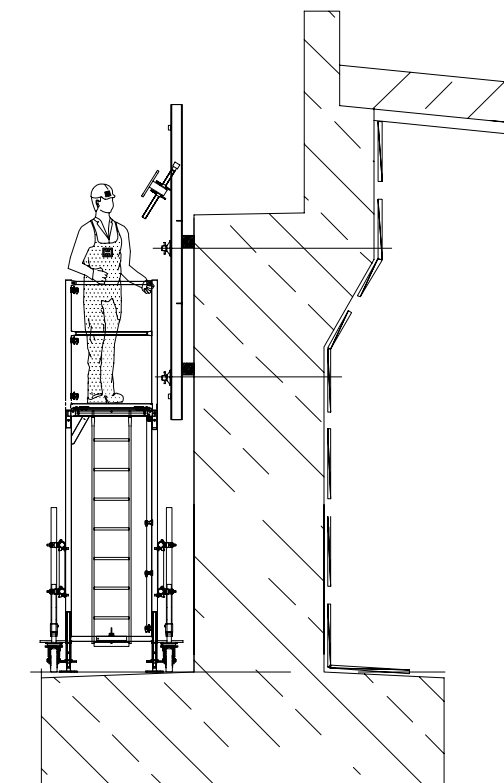
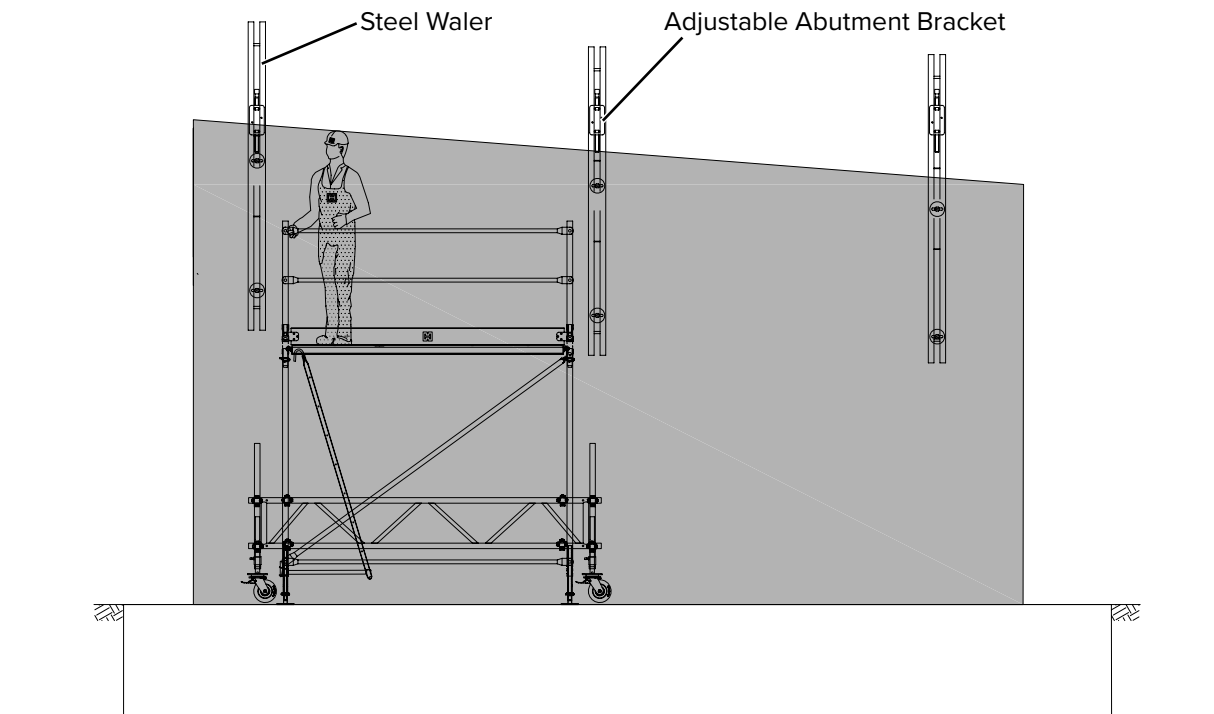

13.2.2 Lower Main Beams

- Step 1** Remove the Connecting Pins from the Main Beams and raise the Main Beams into the assembly position using suitable lifting equipment.
- Step 2** Align the Main Beams and insert the Connecting Pins. Secure the Connecting Pins with lynch pins.

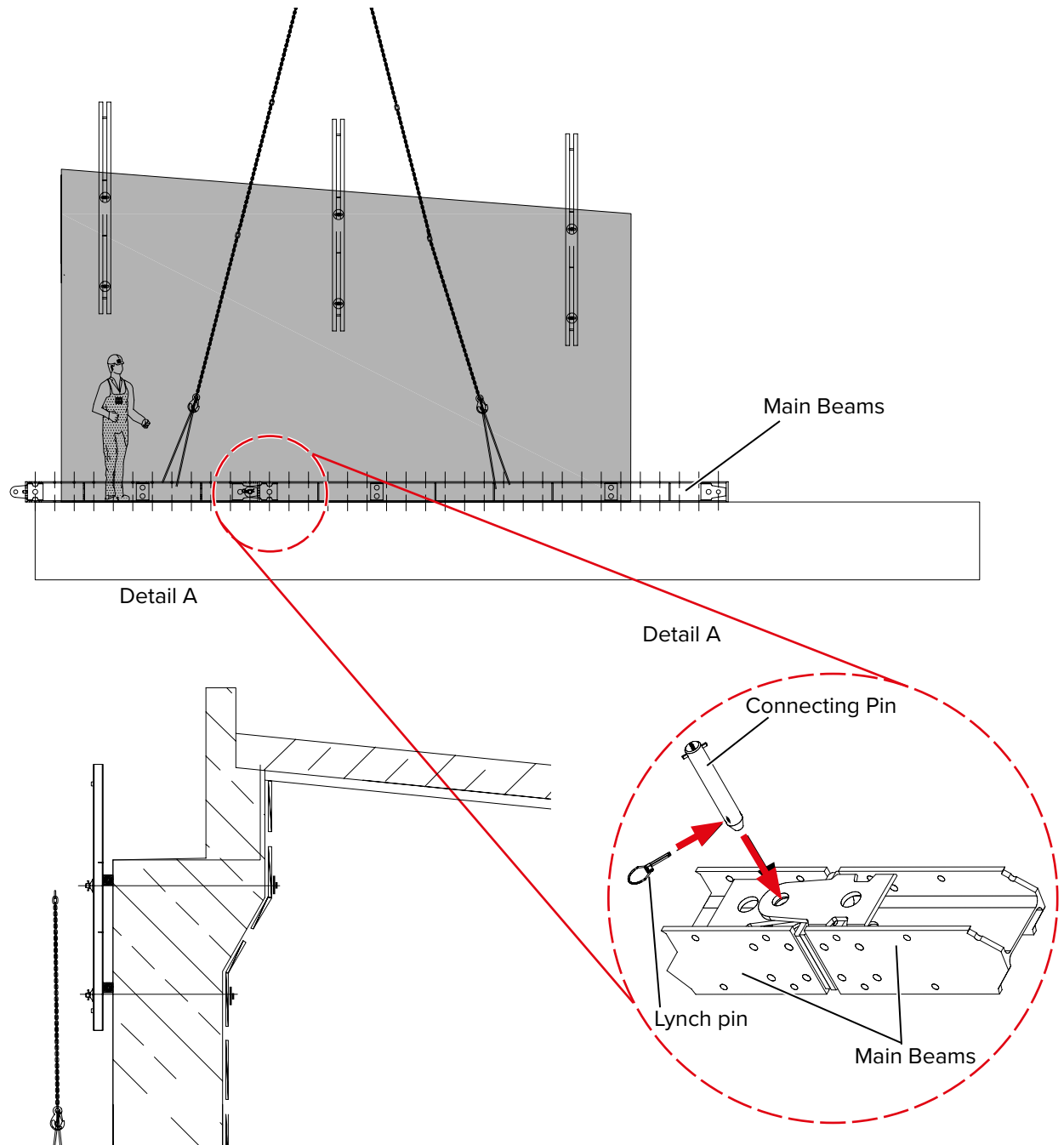

- Step 3** Slide the Main Beams together and secure with the Connecting Pin. Secure the Connecting Pins with lynch pins.

13.2.3 First Load-bearing Frame Prop



WARNING

Warning!

Do not detach from the lifting device until the Load-bearing Frame Prop has been secured to prevent it from tipping or overturning.



BOSTA Scaffold Retainers for securing the Load-bearing Frame Prop have to be ordered separately!



For greater distances between the first and last Load-bearing Frame Prop, the middle Props should be adjusted with 5 cm clearance. Use couplers and horizontal tubes to connect them.

- Step 1** Check actual ground height on site and approximate height of Load-bearing Frame Prop before starting assembly.
- Step 2** Pre-assemble Load-bearing Frame Props (including walkways) to the correct length and pre-adjust the spindles. Alternative: Install the Load-bearing Frame Props step by step.
- Step 3** Fasten the first Load-bearing Frame Prop in the correct position on the lower Main Beam. Use the Load-bearing Frame Prop Bolt Set to connect the Load-bearing Frame Prop to the Main Beam.
- Step 4** Use Wall Struts and Scaffold Retainers to secure the Load-bearing Frame Prop to the existing structure.

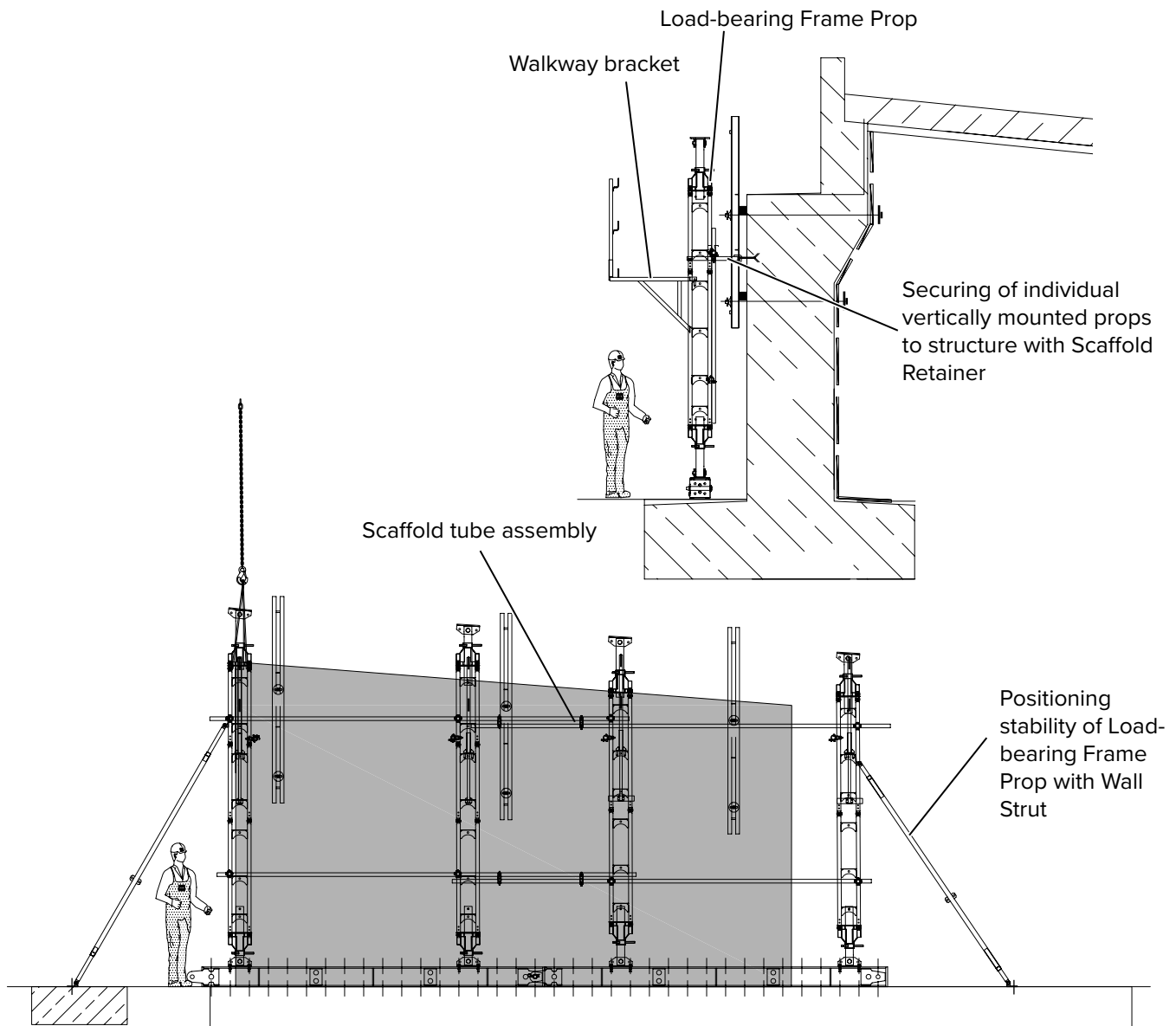

13.2.4 Middle Load-bearing Frame Props



To make the later fine adjustment of the vertical truss to the final height easier, it is advisable to initially leave 5 cm clearance when installing the middle Load-bearing Frame Props to the Head Jack.

- Step 1** Fasten the Load-bearing Frame Prop in the correct position on the lower Main Beam.
- Step 2** Use the Bolt Set to connect the Load-bearing Frame Prop to the Main Beam.
- Step 3** Extend the top Spindles about 5 cm less than the final length.
- Step 4** Use couplers to attach diagonal scaffold tubes to Load-bearing Frame Props.

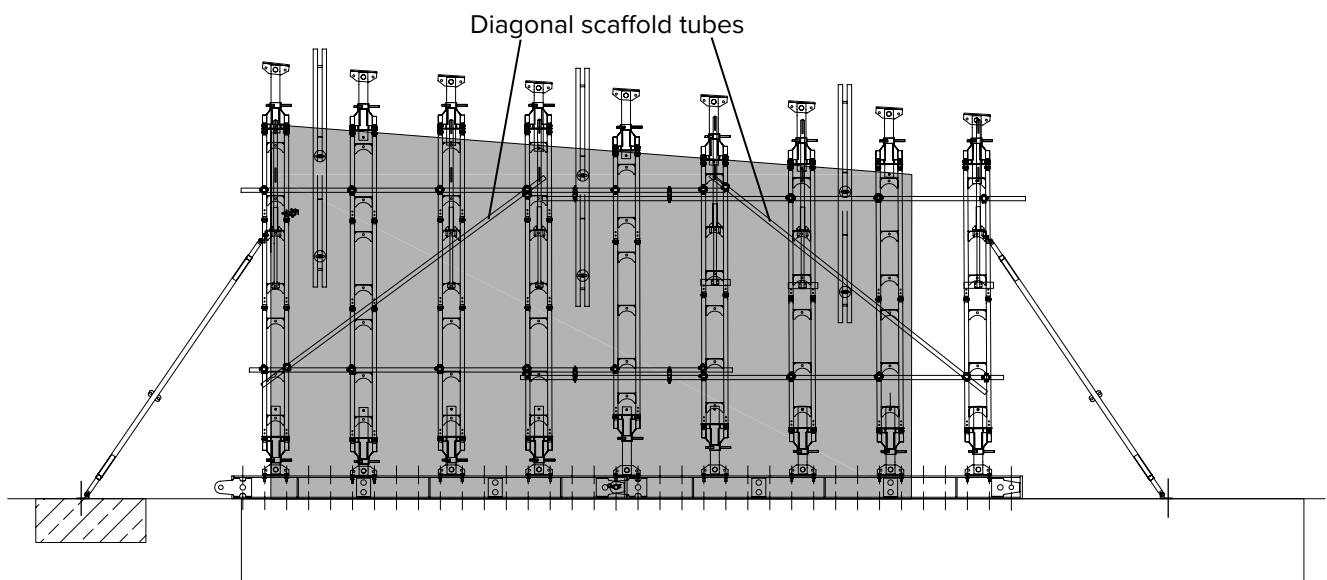
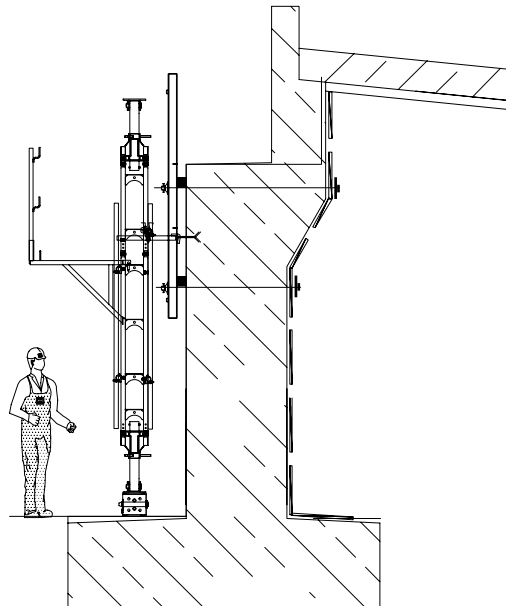

Assembly of INFRA-KIT H

Step 5 Add walkways, planks and railings as needed.

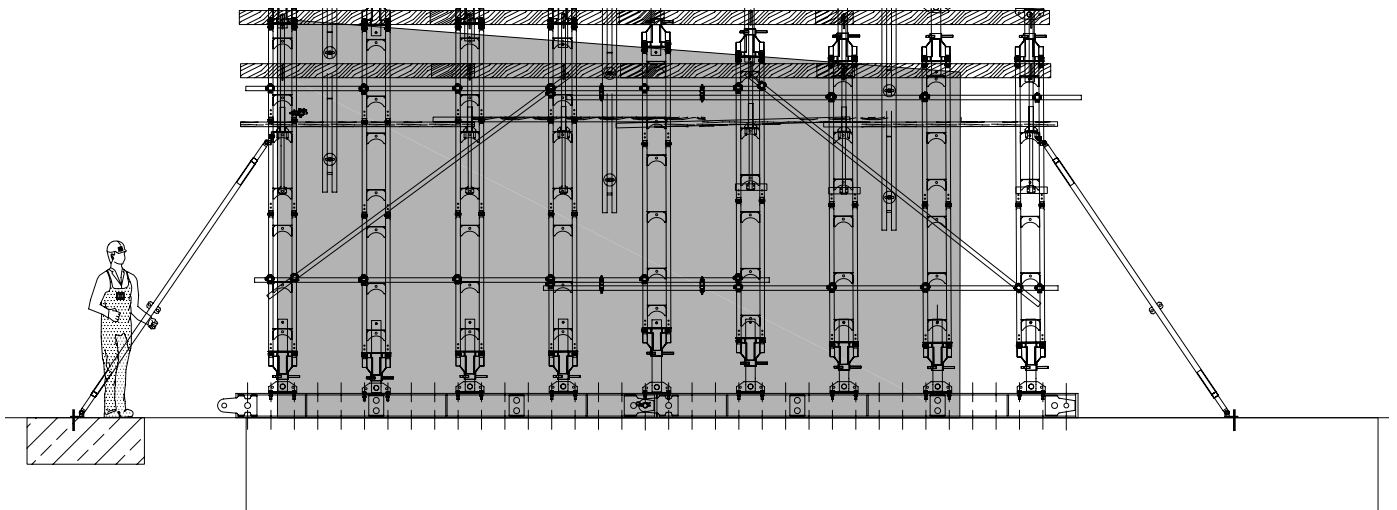
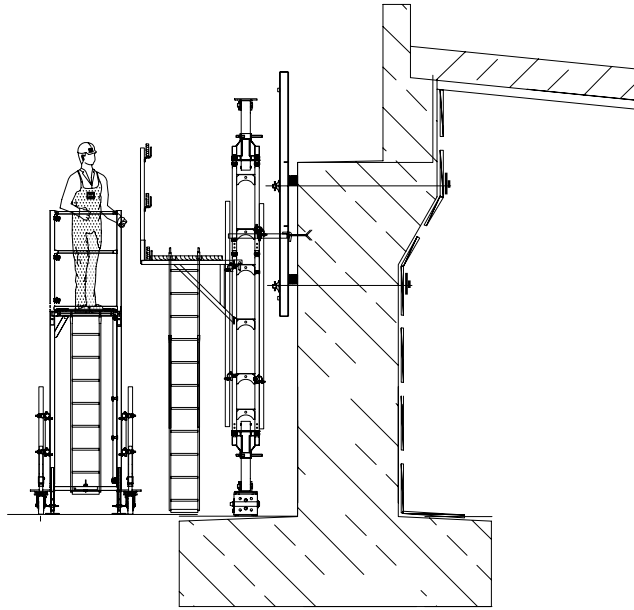

13.2.5 Upper Main Beam

- Step 1** Use suitable lifting equipment to raise the Main Beam to the correct position on the Load-bearing Frame Prop.
- Step 2** Securely screw the Main Beam onto the first and last Load-bearing Frame Prop with the Load-bearing Frame Prop Bolt Set.
- Step 3** Use the Adjustable Abutment Bracket to fasten the upper Main Beam to the existing structure.
- Step 4** Check the height of the Main Beam and adjust via the outer Props if necessary. Extend the upper Spindles of the middle Load-bearing Frame Props to the required length and then fasten them to the upper Main Beam with the Load-bearing Frame Prop Bolt Set.



WARNING

Warning!

Props not fixed with Bolts must be secured with Beam Clamps 16/70.

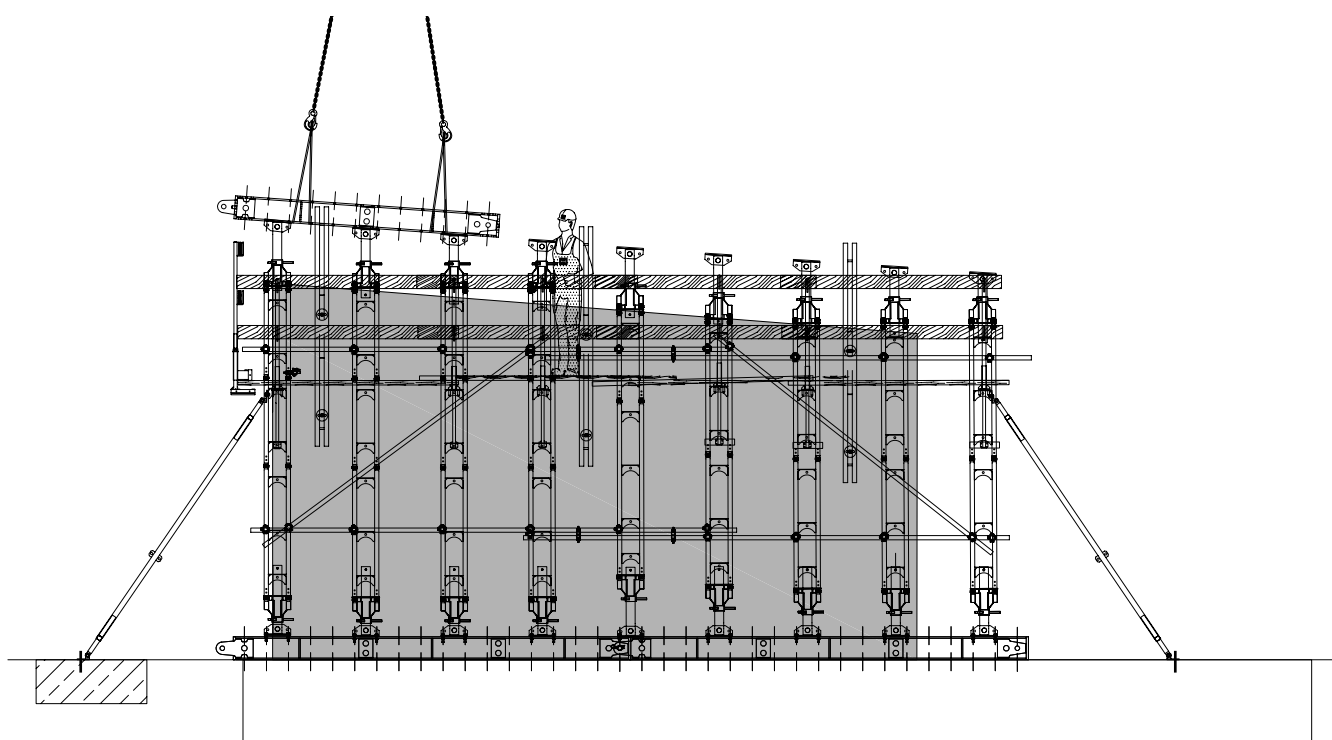
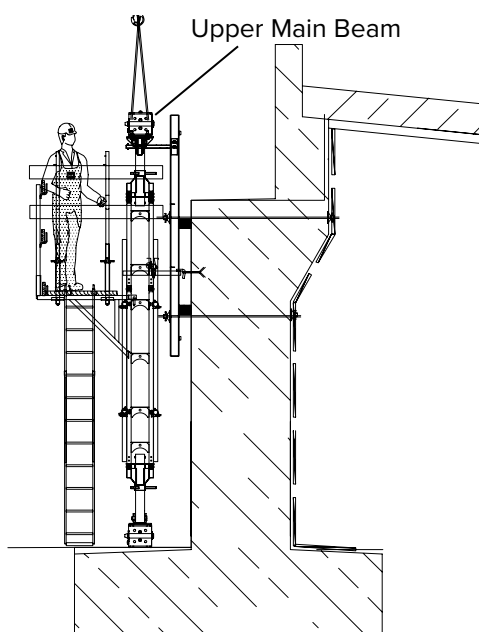

13.2.6 Diagonal Bracing with Tie Rods



WARNING

Warning!

The vertical truss has to rest on its full surface. If necessary add padding materials (e.g. lean concrete).

NOTE

NOTE!

When preloading the Tie Rods DW 15, apply force in increments and crosswise. Avoid different tensile forces in the Tie Rods to prevent damage and deflection.

- Step 1** Insert Tension Bolts.
- Step 2** Attach the Tie Rods crosswise to meet the requirements on site.
- Step 3** Secure the diagonal bracing consisting of Tie Rods to the top side of the Main Beams.
- Step 4** Insert the Tie Rods and tighten against the Tension Bolt to prevent the Tie Rod from twisting.
- Step 5** Tighten the Tension Nut Set DW 15 at the lower end of the Tie Rod (Refer to page 110).
- Step 6** Preload the diagonal Tie Rods step-by-step and crosswise up to 10.00 kN with the Tension Nut Set DW 15 or the Hexagon Nuts 15/50 (Refer to page 127).

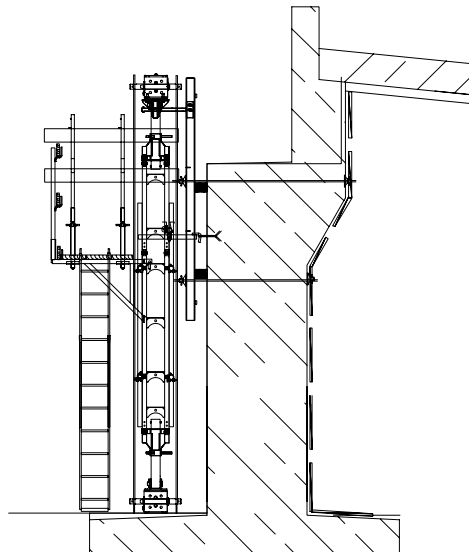

Diagonal bracing

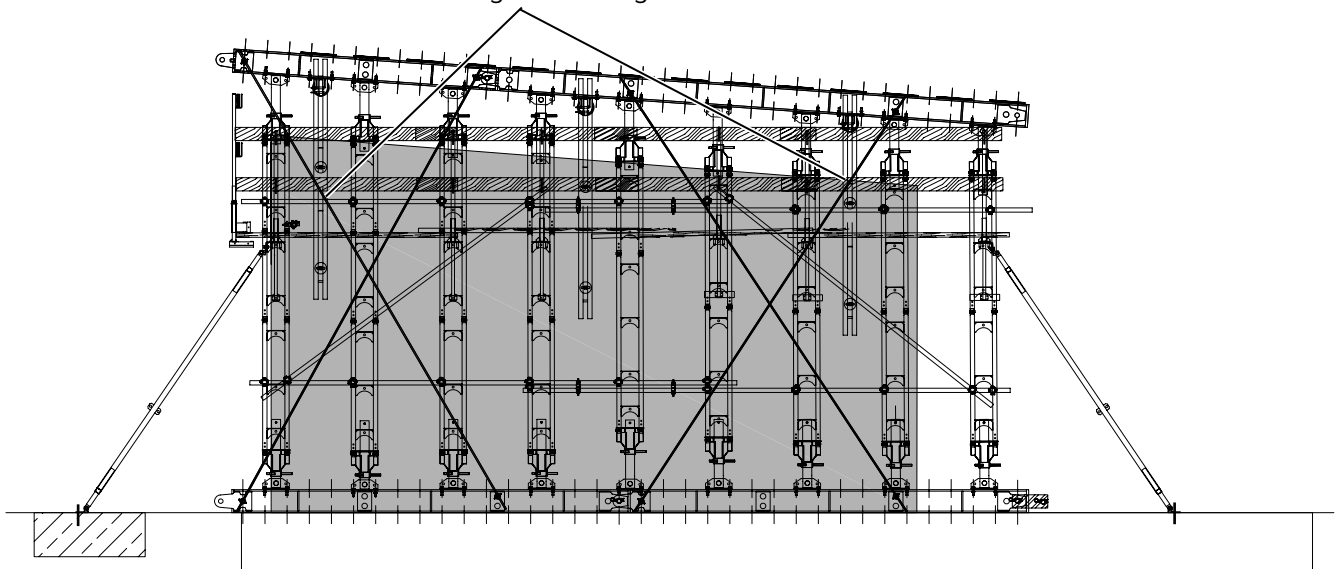

14 Preloading diagonal Tie Rods (INFRA-KIT H)



WARNING

Warning!

Always comply with the preload specified in the structural calculation when assembling the diagonal bracing. Perform the described tasks crosswise on a pair of Tie Rods and within the diagonal bracing until the preload limit is reached. Internal loads caused by preloading have to be considered when dimensioning the Main Beams and Load-bearing Frame Props.

14.1 Countering Tie Rods at top

- Step 1** Attach the two Hexagon Nuts 15/50 to the Tie Rod such that, when the Tie Rods are inserted into the Tension Bolt, they are on both sides of the Tension Bolt. Check that the lynch pin is inserted in the Tension Bolt.
- Step 2** Then tighten both Hexagon Nuts 15/50 against the Tension Bolt on both sides until the Tie Rod is pressed firmly against the Tension Bolt.

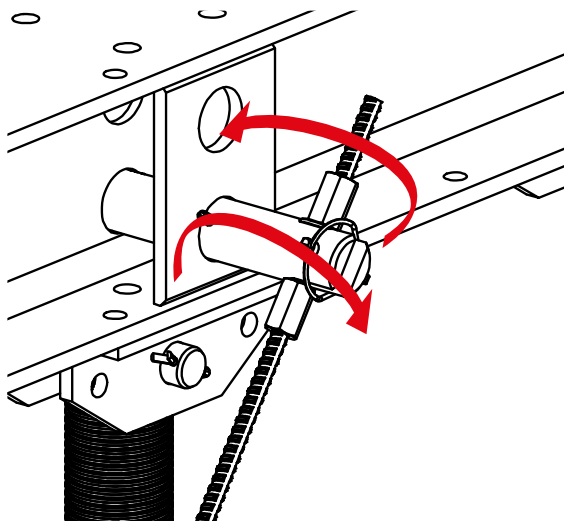

14.2 Preloading Tie Rods at base with Tension Nut Set DW 15

- Step 1** Check that the preload nut is screwed together completely.
- Step 2** Slide the Washer 25 onto the Tie Rod and screw on the preload nut hand-tight.
- Step 3** Tighten the outer nut size w.a.f. 41 against the Tension Bolt until the Tie Rod reaches 10.00 kN preloaded force. Create preload by turning the Tie Rod (Refer to section 6.3) or by applying a defined torque (Refer to section 6.4).

Preloading diagonal Tie Rods (INFRA-KIT H)

Step 4 Apply force crosswise to each Tie Rod pair and to the diagonal bracing (no more than a single turn of the nut) until the required force is achieved.

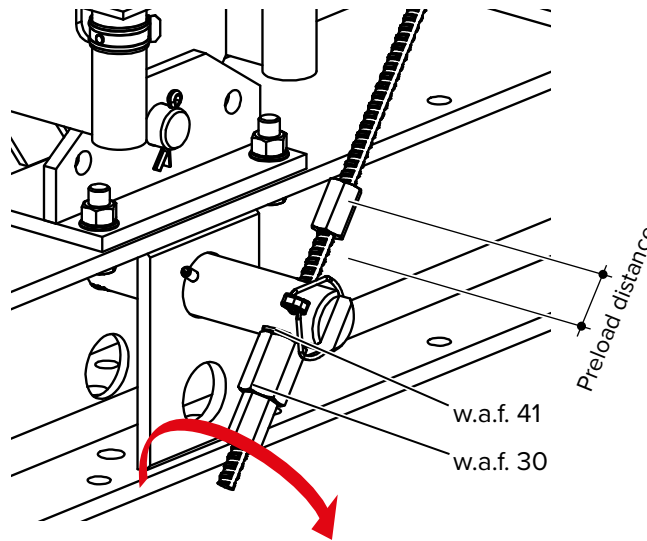

14.3 Imposing defined preload force with tie elongation

- Step 1** Determine the preload distance. It is calculated by applying the tie elongation (Refer to the diagram below) and the distance between the Tension Bolts.
- Step 2** Set the determined preload distance between the Tension Bolt and the inner Hexagon Nut 15/50.
- Step 3** Apply tension to the Tie Rod by turning the preload nut one revolution.
- Step 4** Tighten all of the other Tie Rods in the diagonal bracing.
- Step 5** Repeat this sequence until the inner Hexagon Nut is tensed against the Tension Bolt.

Example of how to calculate tie elongation

- Tie force 10.00 kN
- Tie Rod DW 15, stressed length 6 m
- Slip 1 mm

The diagram shows the tie force in kN and the resulting tie elongation along the line DW 15. In this case it is 03. mm/m.

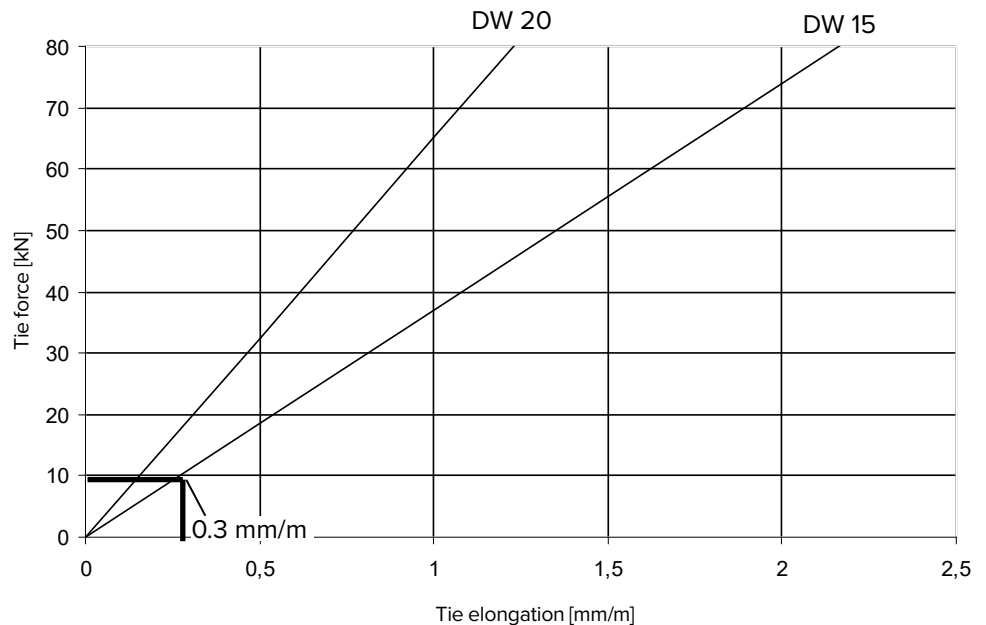

So at a Tie Rod length of 6 m, the preload distance a is:

Formula:

$$\begin{aligned} \text{Preload distance } a &= A = \text{tie elongation (diagram 1)} \cdot \text{stressed length} \\ &\quad + 1 \text{ mm slip} \\ a &= 0.3 \text{ mm/m} \times 6 \text{ m} + 1 \text{ mm} = 2.8 \text{ mm} \\ \Rightarrow \text{preload distance } a &= 3.0 \text{ mm} \end{aligned}$$



WARNING

Warning!

Depending on the capacity of the Tension Bolt, the safe working load (SWL) is restricted to 40.50 kN per Tie Rod.

14.4 Imposing defined preload force with torque

- Step 1** Refer to the diagram for the required torque.
- Step 2** Set the torque spanner to the required torque.
- Step 3** Turn the preload nut one revolution.
- Step 4** Tighten all of the other Tie Rods in the diagonal bracing.
- Step 5** Repeat until the set torque is reached and the torque spanner releases.

Example: DW 15: 10.00 kN = reading 55.00 Nm

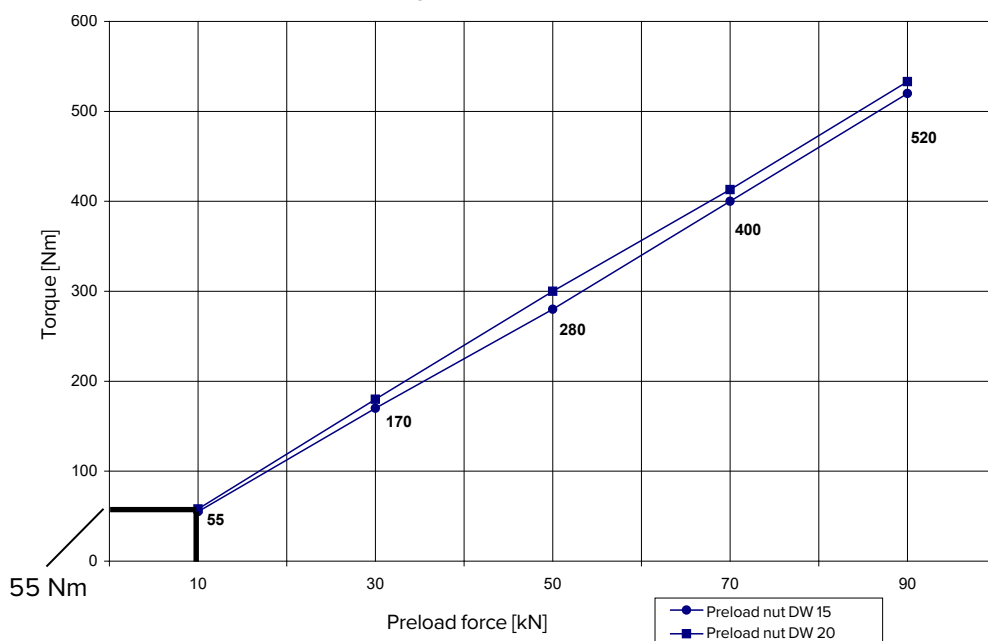

Attaching the Centring Bar

14.5 Torque for bolts with metric thread

Tighten all bolts used with the respective torque indicated in this table!

Torque for high-strength bolts 10.9			
Bolt	Required preload force F_v	Preloading bolts with torque method	
		Required torque M_v	
		MoS ₂ - greased	Slightly greased
	kN	Nm	Nm
M20	160	450	600
M24	220	800	1100

MoS₂ greased for galvanized bolts, slightly oiled - for non-galvanized bolts

15 Attaching the Centring Bar

The Centring Bar transfers vertical loads from the deck into the Main Beams.

Secure the Centring Bar to prevent it from falling or slipping. Use the C-Clip.

Typically a single C-Clip is attached in the groove in the middle of the Centring Bar and clamped to the Main Beam. Up to three clips per bar can be used to secure a Centring Bar.

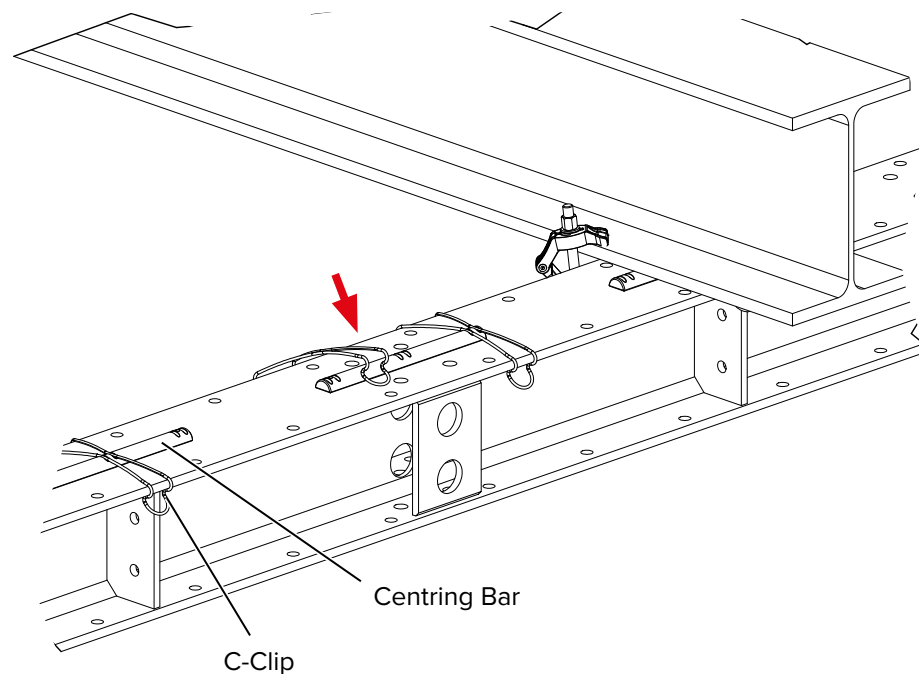

16 Additional example of use

High-load vertical trusses for large spans or bridge renovations/repairs (replacement of bridge bearings).

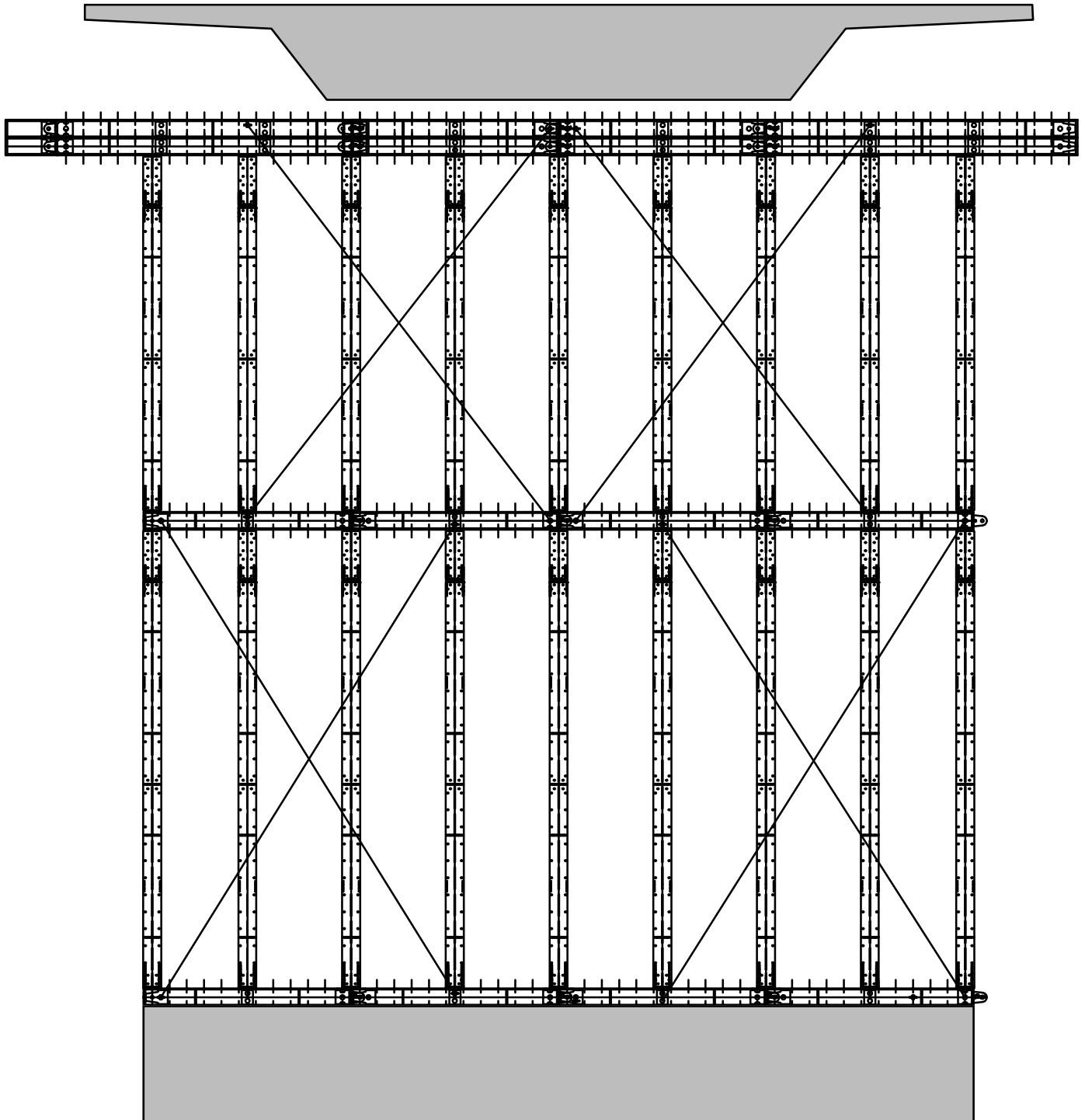

17 Chronology

Changes since edition 2022-09		
Change	Page	Date
Required torque for bolts used to connect the channels of the IK Walers.	48	2023-10-11

Hünnebeck in the UK

Rush Lane, Dosthill
 Tamworth, West Midlands, B77 1LT
 Tel.: +44 (0) 1827 289 955
 info-uk@huennebeck.com
 www.huennebeck.de

The contents of this document, including without limitation, the products, design, images, text, trademarks, service marks and logos contained herein, are protected by copyright and other intellectual property rights. No rights or licences are granted.

The contents of this document are not to be reproduced mechanically, electronically or otherwise, including for distribution, sale or display without our written permission.

The illustrations, processes, materials and/or information in this document are for general information only on the basis that conditions and procedures may differ. No representation, warranty or guarantee is made or implied, including in relation to the fitness or suitability of the product. Overviews and diagrams are for illustrative purposes only.

Specifications may vary and BrandSafway reserves its rights to vary specifications, procedures, and materials due to continuous development, or when required to comply with new regulations, other safety guidance's or industry advancements. The processes set out in the documents should only be undertaken by qualified authorised personnel. The information contained in this document is for use for the applicable product, obtained directly from us.

We may also issue safety notes on products or packaging where required. These notices may affect the manner in which products are used and should therefore be adhered to. The most recent published notice should prevail.

Performance, procedures and results may differ based on actual site conditions.

The aforementioned statements do not seek to limit our liability for fraud, or for personal injury or death caused by our negligence. However, we will not be liable for any damage to property, personal injury or any losses caused by failure to follow the instructions contained in our material. It remains the responsibility of the user to comply with the applicable legislation.

Supply of this product is subject to our terms and conditions. For more information, including on the specification, our terms and conditions/terms of business and for installation and dismantling procedures, please contact us.

© 2023 Hünnebeck GmbH. All rights reserved

Last modified: September 2023
Keep for later use!