

PROTECTO[®]

**Modular, ultramodern fall protection for
a safe work environment**

- ▶ **Technical data**
- ▶ **Product advantages – Work productively**
- ▶ **Product advantages – Work safely**
- ▶ **Components**
- ▶ **Application & use**
- ▶ **Engineering-Services**

At Work For You



HÜNNEBECK 

BY BRAND SAFWAY



PROTECTO®

Technical data

Particularly quick and intuitive assembly with the new height-adjustable Protecto Post 130 and the ergonomic mesh panel. The system meets the requirements of EN 13374:2013 class A.

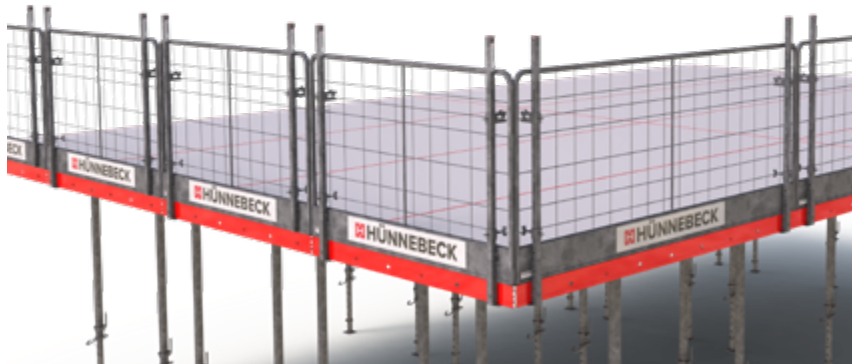

Product description	Temporary edge protection
Posts	PROTECTO railing post 120 cm high (square tube) PROTECTO Post Adjustable, height 130 cm Compression post 200 – 430 cm
Base attachment via	Screw base joint Staircase bracket Beam section clamp Timber beam connector Post holder vari Front attachment Multiple clamp Screw-on holder Sheet pile clamp
Guardrail types	PROTECTO protective grating Plank railings
Toe board attachment	PROTECTO toe board retainer
Corrosion protection	Hot-dip galvanization
Average weight	6.00 – 8.00 kg/running meter
Relevant standards	Complies with EN 13374 – Class A
Maximum post distance	2.00 m using planks 2.70 m using protective grating
Mesh panel width	120 180 240 270 cm
Erection/dismantling times	Approx. 2 m/min; time calculation (average) by Hünnebeck
Special features	<ul style="list-style-type: none"> • Fast, versatile and easy assembly • Integrated safety pin secures the post firmly to base • Height adjustment with post extension 26 and 42

PROTECTO®

Work productively

3

- ▶ Versatile, sturdy modular system with only a few basic components (1)
- ▶ Almost tool-free assembly (2)
- ▶ Lightweight, ergonomic components facilitate quick assembly (3)
- ▶ Lateral transport with Hünnebeck Euro Trolley means no crane required
- ▶ Greatest possible utilisation rate due to compatibility with other Hünnebeck systems



PROTECTO[®]

Work safely

4

- ▶ Post with tension indicator for safe assembly (1)
- ▶ Lift-off retainers offer additional protection (2)
- ▶ PROTECTO Protective Mesh Panels with integrated toe board (3)
- ▶ Greatest possible mesh size facilitates easy handling in the work area (4)
- ▶ PROTECTO Fixing Device For Clamp
- ▶ Hot-dip galvanisation for durable, long-lasting components (5)
- ▶ Panels and plank railings can both be used
- ▶ All components manufactured to comply with DIN EN 13374 – class A, in parts also class B.

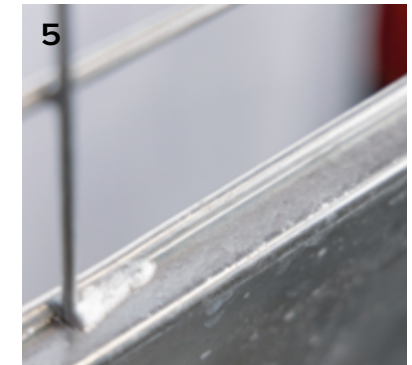
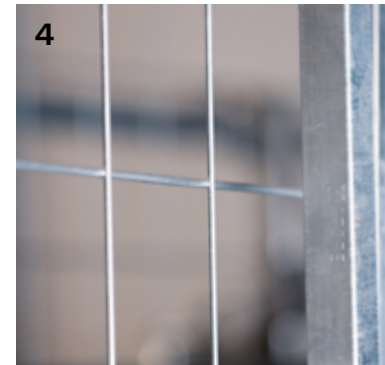
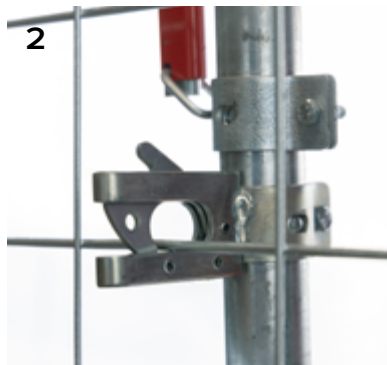

PROTECTO[®]

Components

On the following pages you will find excerpts from our user manuals. The complete instructions are available at www.huenebeck.com.

Panels and posts

The PROTECTO Panel G2 can be used for edge protection on both wet deck and dry deck applications. The PROTECTO Panel G2 is to be used with the PROTECTO posts and depending on the application the required ancillary components will vary.

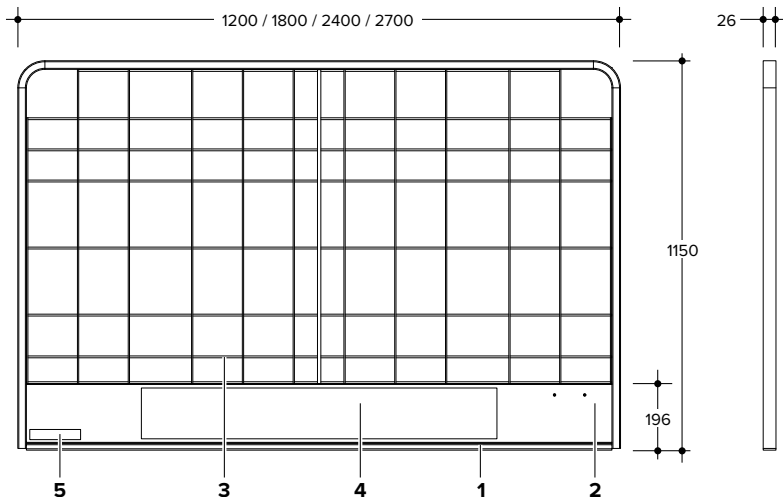

- 1 Steel frame
- 2 Steel toeboard
- 3 Steel wire Ø5.5 mm (horizontal) Ø3.75 mm (vertical)
- 4 Centre sticker (company branding)
- 5 Small sticker (item information)

The minimum required panel overlap is 200 mm as shown below.

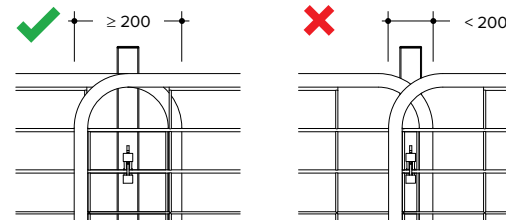

Application & use

- › Slab formwork
- › Climbing formwork
- › Staircases
- › Bracket scaffolds
- › Concrete slabs and walls

PROTECTO[®] integrates with

- › TOPMAX[®]
- › TOPEC[®]
- › TOPFLEX[®]
- › INFRA-KIT
- › H 20 timber beams
- › R 24 timber beams
- › Steel beams

PROTECTO[®]

Components

PROTECTO Post 130 Adjustable

The PROTECTO Post 130 Adjustable (code:692750) provides support for the PROTECTO Panels G2. The post has a cross-section of 35 x 35 mm which allows the PROTECTO Post 130 Adjustable (code:692750) to be used with the ancillaries of the PROTECTO Railing Post (code:601225).

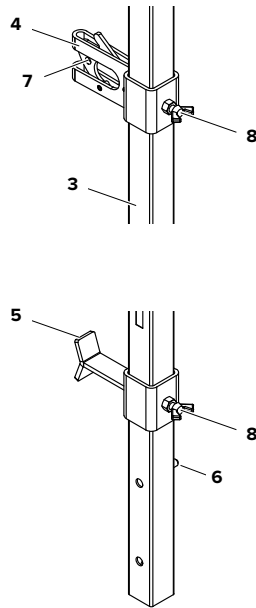
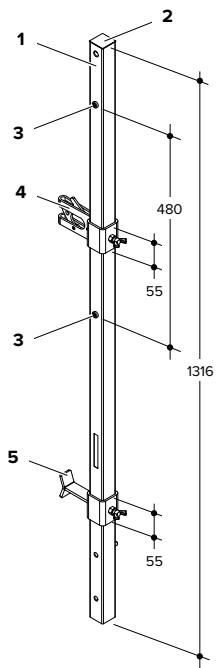

- 1 SHS 35 x 35 x 2 mm
- 2 Plastic cap
- 3 Tapping screw as Ø12 mm stopper
- 4 Sliding latch
- 5 Sliding T latch
- 6 Safety device (not visible) – see page 23
- 7 Ø8 mm hole for plastic zip tie
- 8 Captive hexagonal nut and wing nut

Safety device

The safety device is used to prevent accidental displacement of the PROTECTO posts. Both the PROTECTO Post 130 Adjustable (code:692750) and the PROTECTO Railing Post (code:601225) have a safety device.

To correctly install the PROTECTO posts, insert the post into the retainer and press the actuator pin of the safety lock. The locking pin retracts inside the post and the post can be inserted into the retainer. When the locking pin is inside the retainer piece, release the actuator pin. Insert the post into the retainer until the spring mechanism can be heard and seen as fully locked. Test the proper seating of the post by pulling and inspect visually the correct engagement of the locking pin.

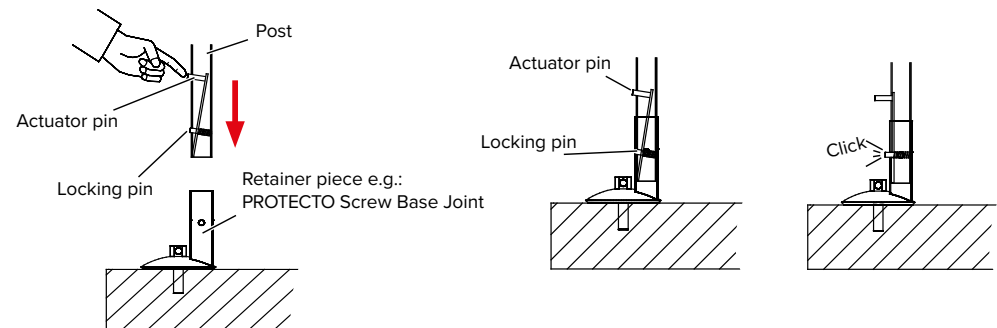

PROTECTO®

Application & use

Slabs with PROTECTO Screw Base Joint

Edge protection can be installed on horizontal concrete slabs by using a PROTECTO Screw Base Joint (code:601228) using the integrated M16 screw to secure to an embedded dowel with internal thread. When using HILTI Drop-in anchor HKD M16 or Fischer ED II M16 hammer-set anchors as anchors in uncracked concrete slabs of C20/25 quality (previously B25), the anchor loads have already been proven according to the example below. Equivalent drop-in anchors/hammer-set anchors from other manufacturers may be used.

The requirements of the dowel approval must be kept. Distance to edges and floor thickness must be taken from the approval of the dowel.

Typical assembly

Step 1 Install the PROTECTO Screw Base Joints (A) at the pre-determined centres.

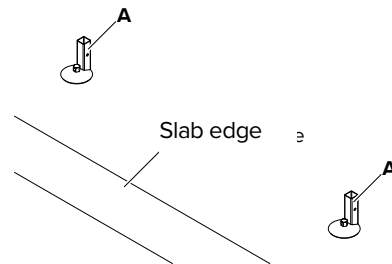

Step 2 Insert the PROTECTO Post 130 Adjustable (B) into the PROTECTO Screw Base Joint (A).

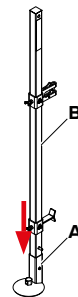

The PROTECTO Post 130 Adjustable is secure when the locking pin is located in the pin hole of the PROTECTO Screw Base Joint. A “click” sound is produced when the pin springs out of the hole.

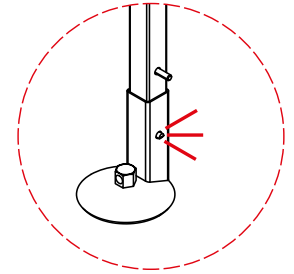

Step 3 Repeat step 2 for the other post position.

Step 4 Position the PROTECTO Panel G2 (C) at an angle, with the bottom part closest to the PROTECTO Post 130 Adjustable (B). Locate the bottom wire of the PROTECTO Panel G2 (C) on the top face of the PROTECTO Post 130 Adjustable T Latch (D). The T Latch (D) may require its position to be adjusted using the captive thumb screw.

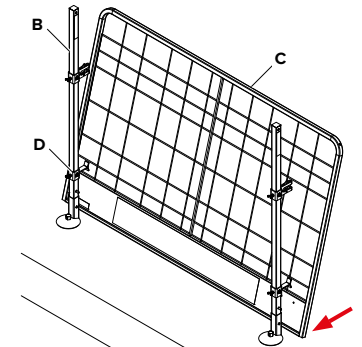

Step 5 Rotate the top of the PROTECTO Panel G2 (C) towards the PROTECTO Post 130 Adjustable (B) so that the latches (E) capture the PROTECTO Panel G2 mesh. The PROTECTO Post latch (E) may require its position to be adjusted using the captive thumb screw.

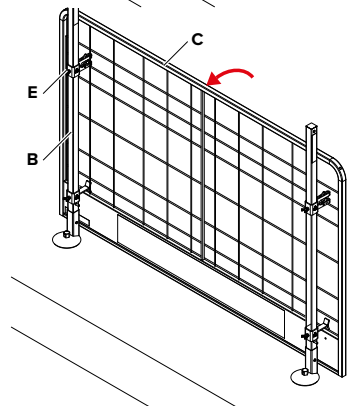

PROTECTO[®]

Engineering-Services

Phase 1
**Wir analysieren
die Situation.**

Phase 2
**Wir erstellen
die technischen
Zeichnungen
und berechnen
die Kosten.**

We can design the most complex projects on your behalf quickly and thoroughly. Starting with the ground plan and facade dimensions, we produce the required structural drawings, determine the precise quantities of materials and supply all the required quantity lists.

We help in finding the right safety and access solution. Transparency, flexibility, cost-effectiveness and safety are a matter of course for us and an integral part of our corporate philosophy.

Whatever it takes! We assist you throughout complex construction projects including the engineering of one-off structures. Our mission at all times is to protect you from any unnecessary risks and help you arrive at the best-possible results in every respect.

Phase 3
**Wir planen
und implemen-
tieren die
Ausführung.**

Phase 4
**Wir unter-
stützen Sie
bei der Projekt-
abwicklung.**