

Slab formwork

# H 20 Floor Tables

Based on the H 20 timber beam as both the primary and secondary beam, the H 20 floor tables arrive on site pre-assembled.

- › Technical data
- › Product advantages – work safely
- › Product advantages – work productively
- › Engineering services

BrandSafway  
direct.com



Shop Smart Online.  
Worldwide. 24/7.



more safety  
more productivity

# ID 15new

## Technical data

Buildings with intricate ground plans and different story heights are difficult to form. This is where our table forms are a recommendable solution with their high load-bearing ability.

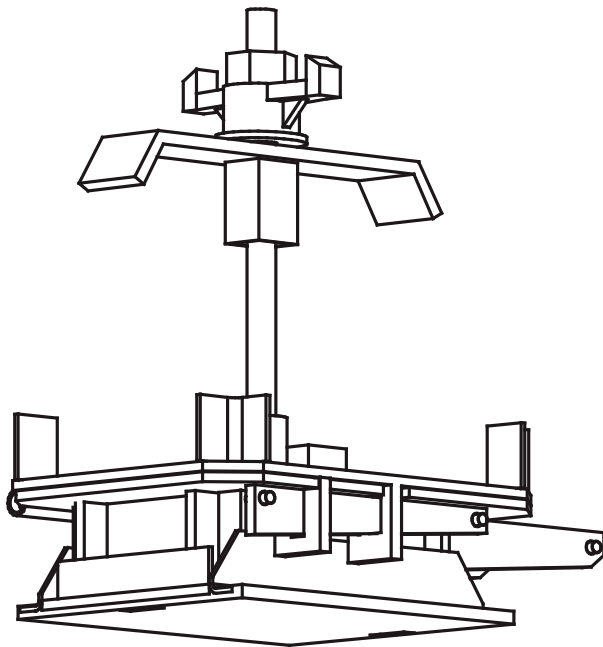

Product description	H 20 floor tables for slabs
Material	H 20 timber beams   Double primary & single secondary beams
Table sizes	2.50 x 4.00 m (10.00 m <sup>2</sup> )   2.50 x 5.00 (12.50 m <sup>2</sup> )
Table height	Approx. 50 cm (including table heads)
Form lining	Plywood   21 mm thickness
Table weight	2.50 x 4.00 = 345 kg   2.50 x 5.00 = 417 kg (without props)
Max. slab thickness	Up to 45 cm (2.50 x 4.00)   Up to 35 cm (2.50 x 5.00)
Usable props	EUROPLUS 20 kN   EUROPLUSnew 30 kN
Connections of props	Using HT-table head
Relevant standards	DIN 18202 (line 5, 6)
Areas of application	Large-area slabs

Steel props are mounted to the table by using the HT-table heads. All connecting parts are integrated. A plastic cap arrests the locking steel wedges during transportation without steel props. In this way, damage to the plywood sheet is avoided when stacking the floor tables.

more safety  
more productivity

# H 20 Floor Tables

## Work safely

- › Compatibility with the PROTECTO edge protection system offers extra safety with guardrailing (multiple clamps, posts, etc.) (1)
- › Props are easily and safely installed by simply hammering in the steel wedges



more safety  
more productivity

# H 20 Floor Tables

## Work productively

- › Pre-assembled H 20 floor tables are delivered to job sites for immediate use
- › Quick and easy assembly of steel props due to convenient wedge connections
- › Ready-to-use units with pre-assembled folding heads
- › Floor tables can form large-area slabs quickly and economically
- › Provided with built-in table heads and hinged plate for easy fixing of steel props
- › Hinged plates allow props to fold up for better maneuvering in case of parapets (1)
- › Using the H 20 crane hooks, the tables can be transferred safely with ease
- › Together with the 21 mm thick plywood form lining, H 20 floor tables can form slabs up to a thickness of 45 cm (2)

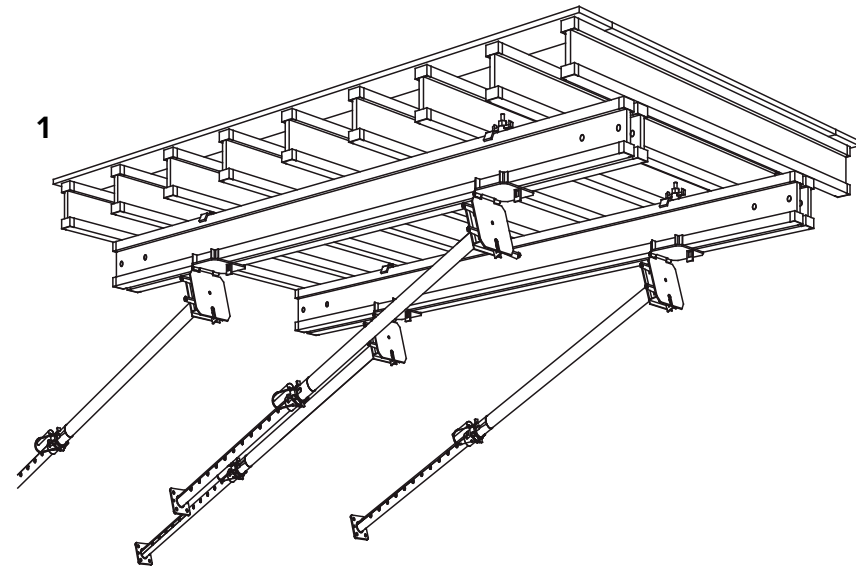

more safety  
more productivity

# H 20 Floor Tables

## Engineering-Services

### Phase 1

**We analyse the situation.**



### Phase 2

**We develop the technical drawings and supply the required quantity list.**



We can design the most complex projects on your behalf quickly and thoroughly. Starting with the ground plan and facade dimensions, we produce the required structural drawings, determine the precise quantities of materials and supply all the required quantity lists.

We help in finding the right safety and access solution. Transparency, flexibility, cost-effectiveness and safety are a matter of course for us and an integral part of our corporate philosophy.

Whatever it takes! We assist you throughout complex construction projects including the engineering of one-off structures. Our mission at all times is to protect you from any unnecessary risks and help you arrive at the best-possible results in every respect.

### Phase 3

**We plan and implement the realisation.**



### Phase 4

**We assist with project finalisation.**



### Application & use

- › Shoring system for high loads

### ID 15new integrates with

- › PROTECTO®
- › TOPFLEX®

**more safety**  
**more productivity**

**HÜNNEBECK**   
**FORMWORK SOLUTIONS**  
BY BRAND SAFWAY

> best in class safety performance

Why BrandSafway?

## Unique combination of expertise & resources

We are part of **BrandSafway**, a leading global provider of access, specialised services and forming & shoring solutions to the industrial, commercial and infrastructure end markets. With more than 340 branches all over the world, we provide support for ongoing maintenance as well as for refurbishment needs and new construction plans.

**As one strong team, we support our customers:**

- > **Brand Energy & Infrastructure Services** is one of the world's largest industrial services specialists;
- > **Brand Access Solutions** is the UK's largest full-service provider of scaffolding and access systems;
- > **Hünnebeck** stands for safe and highly efficient formwork, scaffolding and safety technology.

> specialty team of ~40,000 People

> 30,000+ customers ... and growing

> ~340 locations in 25 Countries

> revenues of nearly ~\$5b

> assets & equipment worth ~\$4.2b

[More about BrandSafway](#)



## Contact

### Europe

**Hünnebeck Austria GmbH**

Royerstraße 2  
2482 Münchendorf  
+43 2259 93080  
www.huennebeck.com/at

**Hünnebeck Deutschland GmbH**

Rehhecke 80  
40885 Ratingen  
+49 2102 9371  
www.huennebeck.com/de

**Hünnebeck v Česká republika**

Karolinská 661/4  
186 00 Praha 8  
+420 737 715 140  
www.huennebeck.com/cz

**Hünnebeck in Luxembourg**

53, Rue Romain Fandel  
4149 Schifflange  
+352 265759  
www.brandfrance.fr

**Hünnebeck in France**

Allée de Fétan 256  
BP 130 01601 Trévoux  
+33 4740 89050  
www.huennebeck.com/fr

**Hünnebeck Italia S.p.A.**

Via Isonzo, 9  
22078 Turate (Como)  
+39 2 969731  
www.huennebeck.com/it

**Hünnebeck Netherlands**

Vlietskade 1019  
4241 WE Arkel, ZH  
+31 183 569 696  
www.huennebeck.com/nl

**Hünnebeck Polska Sp. z o.o.**

Łubna 55  
05-532 Baniocha  
+48 22 2312300  
www.huennebeck.com/pl

**Hünnebeck România SRL**

Strada Principala nr. 310  
407145 Capusu Mare, jud.Cluj  
+40 755 045568  
www.huennebeck.com/ro

**Hünnebeck in the UK**

Rush Lane, Dosthill  
Tamworth, West Midlands, B77 1LT  
+44 1827 289955  
www.huennebeck.com

**Contact for Hünnebeck products in North America**

**BrandSafway**  
Global Corporate Headquarters  
600 Galleria Parkway SE, Suite 1100  
Atlanta, GA 30339, USA  
+1 800 558-4772  
www.brandsafway.com

**Latin and South America**

**Hünnebeck Chile**  
Volcán Lascar Poniente 792,  
Parque Industrial Lo Boza, Pudahuel  
Santiago, 9030922  
+56 2 2585 4450  
www.huennebeck.com/es

**Contact for Hünnebeck products in the Middle East, India and Asia**

**BrandSafway**  
Flat No. 107, H-AI Manama building,  
Industrial Area  
Dubai Sharjah 37656  
United Arab Emirates  
+971 48132000  
www.brandsafway.com

**Export**

Rehhecke 80  
40885 Ratingen  
+49 157 80521302  
www.brandsafwaydirect.com

All the trademarks named in this brochure are the property of Brand Industrial Services, Inc., known as BrandSafway, unless marked as third-party rights or identifiable as such in another way. Aluma Systems, Brand, Brand Access Solutions, Hünnebeck, Mastclimbers, and SGB are trademarks of BrandSafway. Furthermore, all rights are reserved, particularly with regard to patent grant or utility model registration. The unauthorized use of these materials, of the trademarks contained therein and other intellectual property rights is expressly prohibited and represents an infringement of copyright, trademark rights and other industrial property rights.

The illustrations in this brochure depict actual site conditions which may not always conform with applicable safety rules and regulations.