

MANTO[®]

MANTO is a crane-set formwork system (80 kN/m²) for large-area forming of walls.



At Work For You

HÜNNEBECK 

BY BRAND SAFWAY

A very versatile and heavy-duty system that is equal to very tough challenges. 40 m² can be moved in a single crane pick.

► Product benefits

Versatile

Broad range of panel sizes up to a height of 3.30 m

Two stacked large panels form one unit with an astonishing 26 m² surface area

Also suitable for forming of single-sided walls

All panels can be used horizontally and vertically and can be combined in any way

Strong & durable

High flexural strength due to 14 cm steel profile, concrete pressure 80 kN/m²

Fully galvanised steel frame and connection elements

Economical

Strong connection thanks to aligning clamp: 40 m² can be moved in a single crane pick

Easy and quick forming and stripping of shafts due to the MANTO shaft corner

Easy handling

Multi-purpose panels for easy forming of columns

MANTO shaft corner for a system-compatible shaft formwork

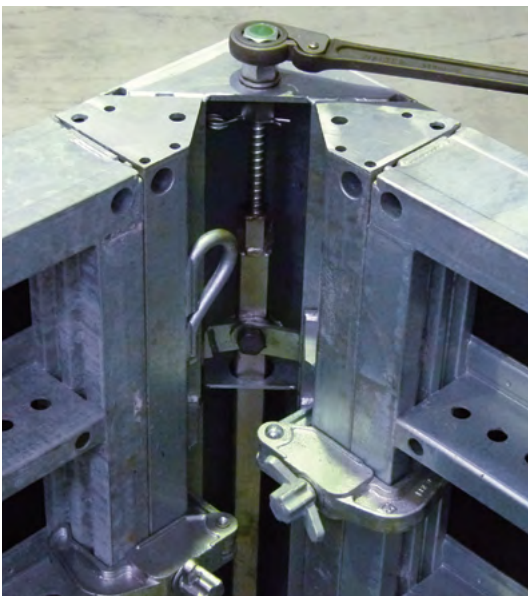

► Easy and quick forming and stripping of shafts due to the MANTO shaft corner



► By using facade soldiers, the 16.73 m high walls of a terminal were shuttered in two pouring cycles instead of three.

► Technical data

Product description	Crane-set large area wall formwork
Panel widths	30 45 60 75 90 105 120 240 cm
Panel heights	120 270 330 cm
Multi-purpose panels	75 x 60 75 x 120 75 x 270 75 x 330 cm
Profile thickness	14 cm steel frame profile (closed)
Form lining	Plywood (min. 280 g/m ² coating) ECOPLY full plastic composite sheet
Form lining thickness	Plywood = 18 mm ECOPLY full plastic composite sheet = 19 mm
Average weight	55 to 75 kg/m ² (including connection parts)
Max. concrete pressure	80 kN/m ² (line 6, some line 7)
Corrosion protection	Fully galvanised steel frame and connection elements
Relevant standards	Complies with DIN 18216 EN 1993
Standard connection	Aligning clamp (aligned and flush connection)
Special connection	Adjustable aligning clamp Corner clamp
Inner corners	35/35 cm (with 2.5° play for easing)
Hinged corners	60° to max. 175° angle
Outer corners	Basic panel with outer corner clamps
Forming/stripping times	t = 0.20 – 0.40 h/m ² *
Special features	<ul style="list-style-type: none"> • Large panels 240 360 480 x 270 cm • MANTO shaft corner for easier forming of shafts • High quality form lining on all panels • Extensive accessory parts program

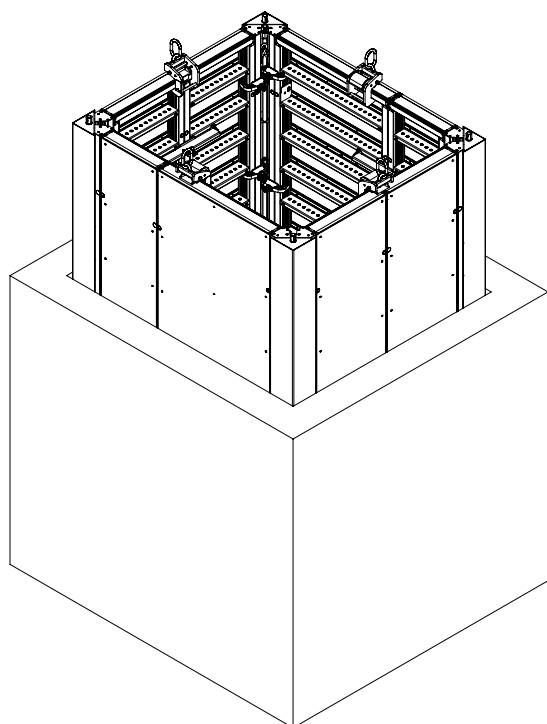

◀ By using the mechanism of the shaft corner, the formwork can be fully released from the concrete in an instant, and it can then be lifted out by a crane in one go. It is operated from above by means of a readily accessible set-screw. No special tools are required.

* Time calculation (average) by Hünnebeck



▶ A special solution: Facade walers are used to ensure back anchoring of the horizontal loads and to enable the exact alignment of the MANTO formwork in a desired inclined position.

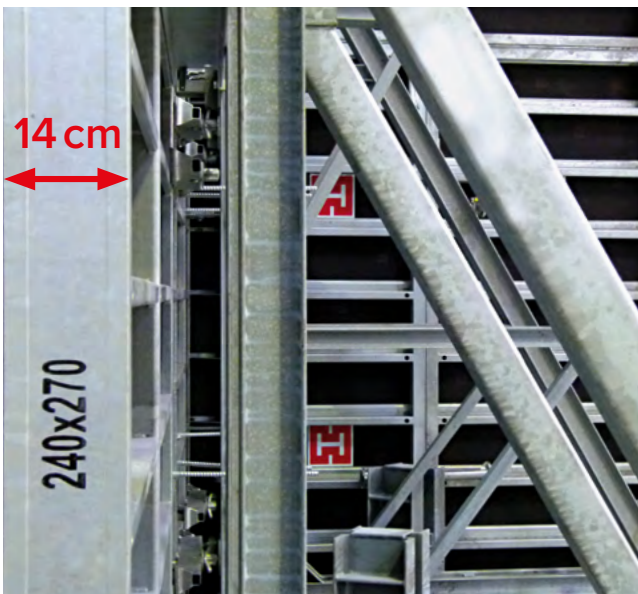

▶ High flexural strength due to 14 cm steel profile, concrete pressure 80 kN/m²

Application & use

- ▶ Options from small to large panels
- ▶ Single-sided wall applications
- ▶ Column forms

MANTO® integrates with

- ▶ PLATINUM platform system
- ▶ Aligning struts
- ▶ RONDA®
- ▶ Support frames