

PLATINUM[®] 100

Large-frame panel formwork

User guide



HÜNNEBECK 

BY BRAND SAFWAY

Contents

1	Product features	4
2	General	4
2.1	Safety instructions	5
3	Overview	8
4	Components	10
4.1	PLATINUM 100 basic panels	10
4.2	PLATINUM 100 panels with extra tie points in the edge profile	10
4.3	Extension panels	11
4.4	Multipurpose panels (MP)	12
4.5	Lifting gears	14
4.6	Tie rod	14
4.7	Plugs	15
4.8	Connection parts	16
4.9	ANCHORS	19
4.10	PLATINUM 100 SCC concrete pump port	19
5	Details of the PLATINUM 100 formwork	20
5.1	Load bearing capacity	20
5.2	Concrete surface	20
5.3	Steel frame	21
5.4	Tie hole	22
5.5	Frame corner	22
5.6	RFID technology	23
5.7	Handles	24
5.8	Labels	24
5.9	Bracket for PLATINUM aligning wedge clamp	25
5.10	Connection options for accessories	26
6	Combinations and panel grid	28
6.1	Possible combinations	28
6.2	Tie arrangement and fresh concrete pressure	29
6.3	Tie arrangement with extension panels at the top	30
6.4	Tie arrangement with extension panels at the bottom	31
6.5	PLATINUM 100 basic panels	31
6.6	PLATINUM 100 panels with additional edge tie holes	32
6.7	PLATINUM 100 multipurpose (MP) panels	33
6.8	Panel overview	35
7	Connection of panels	36
7.1	PLATINUM 100 aligning wedge clamp	36
7.2	Operation of the aligning wedge clamp	38
7.3	Elevation steps between panels	39
7.4	Vertical connection and stacking	40
7.5	PLATINUM 100 MANTO extension bar	42
8	Tie technology	52
8.1	Tie holes of panels	52
8.2	Preparing the tie hole	53
8.3	Assembly of sealing cone and universal flat ring	54

8.4	Removal of sealing ring and universal flat ring	54
8.5	PLATINUM 100 tie rod.....	55
8.6	Traditional DW 20 ties	63
8.7	Tie rod inclines and elevation changes	64
9	Length adjustments, corners	65
9.1	Length adjustments with universal connector (up to 15 cm)	65
9.2	Length adjustments using waler 100 (15 - 45 cm)	67
9.3	Adjustments without ties with hydrostatic load up to 90 kN/m ² and up to 3.60 m formwork height.....	68
9.4	Full area load with 3.00 m panel height 100 kN/m ²	70
9.5	90° Corners.....	72
9.6	Angled Corners	76
9.7	Obtuse-angled corners	78
9.8	Acute-angled corner	79
9.9	T-walls with the inside corner 90°.....	80
9.10	Wall connection with length adjustment.....	81
9.11	T-walls and pilasters with MP inside corners.....	81
9.12	Panel connections with increased tensile loads.....	82
9.13	Window and door boxouts	86
10	Column formwork.....	87
10.1	PLATINUM 100 MP panel.....	88
11	Bulkhead formwork.....	89
11.1	With PLATINUM 100 MP panels	89
11.2	With the bulkhead clamp	91
11.3	With multi bolt and steel waler <42.5 cm	92
12	Foundation formwork	94
13	Anchors.....	96
14	Panel bracing	100
14.1	Bracing up to 390 cm form height	100
14.2	Bracing higher than 390 cm form height.....	101
15	Platform and access systems	103
15.1	PLATINUM 100 platform and access system.....	103
15.2	PLATINUM 100 platform step.....	104
15.3	Walkway bracket	105
15.4	Pouring platform.....	107
16	Panel transport	112
16.1	With the PLATINUM 100 transport hook.....	112
16.2	With the PLATINUM 100 transport hook plus.....	114
16.3	Transport of panel bundles	116
16.4	Turning of single PLATINUM 100 panels	119
17	SCC concrete pump port.....	120
18	Notes on structural analysis	125
19	Chronology.....	126

1 Product features

PLATINUM 100 from HÜNNEBECK is a crane-dependent and very robust system formwork for high-quality concrete results. The “ready-to-use” basic panels in sizes from 2.40 m x 3.60 m and 2.40 x 3.00 m allow particularly efficient forming of large walls in all areas of concrete construction.

With compatible height and width combinations, it is possible to achieve a consistently symmetrical tie and joint pattern. Capable of withstanding fresh concrete pressure of up to 100 kN/m², HÜNNEBECK PLATINUM 100 allows quick and safe concreting and achieves high-quality flatness results in accordance with DIN 18202 table 3, row 7.

Different tie arrangements allow during hydrostatical fresh concrete pressure a reduction of form ties by up to 33%. The innovative PLATINUM 100 tie saves time with a simple operation from one side only and requires neither spreader nor thru tube.

The PLATINUM 100 panels are equipped with brackets that secure the standard connection clamps within the panel frame. This achieves the right amount of clamps at the right place, reducing the number of loose parts and saving additional time on site. The PLATINUM 100 aligning wedge clamps deliver a sealed joint that is flush and secure.

The 14 cm thick frame is galvanized on the inside and outside, giving the HÜNNEBECK PLATINUM 100 formwork its unique strength and robustness.

The PLATINUM 100 panels achieve excellent concrete surface results without imprints of rivets due to its full-plastic, high-quality ECOPLY form sheets that are connected to the frames from the back.

Each PLATINUM 100 panel is equipped with four RFID chips. These chips allow the unique identification of the panel.

2 General

This user guide includes important information as well as relevant safety precautions for the assembly and use of HÜNNEBECK PLATINUM 100 formwork.

This user guide is intended as an aid to achieve efficiency when working with HÜNNEBECK PLATINUM 100. It is therefore important to read this user guide carefully before setting up and using HÜNNEBECK PLATINUM 100. Keep this user guide handy for reference and store them in a safe place for future use.

HÜNNEBECK products are exclusively for commercial use by professionally qualified personnel.

This user guide is intended for commercial users with appropriate technical training. The contents and processes described are in accordance with the legal and occupational safety regulations of Germany and Austria. HÜNNEBECK assumes no liability for deviations from the contents and processes described or for use outside this area of application.

2.1 Safety instructions

Important information regarding the intended use and safe application of formwork and falsework

The contractor is responsible for drawing up a comprehensive risk assessment and a set of installation instructions. The latter is not usually identical to the user guide.

- **Risk assessment**
The contractor is responsible for the compilation, documentation, implementation and revision of a risk assessment for each construction site. Employees are obliged to implement the measures resulting from this in accordance with all legal requirements.
- **Installation instructions**
The contractor is responsible for compiling a written set of installation instructions. The user guide forms part of the basis for the compilation of a set of installation instructions.
- **User guide**
Formwork is technical work equipment that is intended for commercial use only. The product must be used as intended exclusively by properly trained personnel and appropriately qualified supervising personnel. The user guide is an integral component of the formwork construction. It comprises minimum safety guidelines, details on the standard configuration and intended use, as well as the system description. The functional instructions (standard configuration) contained in the user guide are to be complied with as stated. Enhancements, deviations or changes represent a potential risk and therefore require separate verification (with the help of a risk assessment) or a set of installation instructions that comply with the relevant laws, standards and safety regulations. The same applies in those cases where formwork and/or falsework components are provided by the contractor.
- **Availability of the user guide**
The contractor has to ensure that the user guide provided by the manufacturer or formwork supplier is available at the place of use. Site personnel are to be informed of this before assembly and use takes place, and that the user guide is available at all times.
- **Representations**
The representations shown in the user guide are, in part, situations of assembly and not always complete in terms of safety considerations. The safety installations that may not be shown in these representations must nevertheless be available.
- **Storage and transportation**
The special requirements of the respective formwork constructions regarding transportation procedures as well as storage must be complied with. For example, the appropriate lifting gear should be indicated.
- **Material check**
Formwork and falsework material deliveries are to be checked on arrival at the construction site/place of destination as well as before each use to ensure that they are in perfect condition and function correctly. Changes to the formwork materials are not permitted.
- **Spare parts and repairs**
Only original components may be used as spare parts. Repairs are to be carried out by the manufacturer or authorized repair facilities only.
- **Use of other products**
Combining formwork components from different manufacturers carries certain risks. They are to be individually verified and can result in the compilation of a separate set of assembly instructions required for the installation of the equipment.
- **Safety warnings, NOTE (DIN EN 82079-1) and visual check**
The individual safety messages or notes (Ansi 535.4) and the visual check are to be complied with.



DANGER

Danger!

DANGER indicates a hazardous situation which, if not avoided, will result in death or serious injury.



WARNING

Warning!

WARNING indicates a hazardous situation which, if not avoided, could result in death or serious injury.



CAUTION

Caution!

CAUTION used with the safety alert symbol indicates a hazardous situation which, if not avoided, could result in minor or moderate injury.

NOTE

Note!

NOTE refers to practices not related to personal injury.



VISUAL CHECK

VISUAL CHECK refers to a visual check and is not related to personal injury.

- Miscellaneous

Technical improvements and modifications are subject to change without note.

For the safety-related application and use of the products, all current country-specific laws, standards and other safety regulations are to be complied with without exception. They form a part of the obligations of employers and employees regarding industrial safety. This results in, among other things, the responsibility of the contractor to ensure the stability of the formwork and falsework constructions as well as the structure during all stages of construction.

This also includes the basic assembly, dismantling and the transport of the formwork and falsework constructions or their components. The complete construction is to be checked during and after assembly.



Copyright: Güteschutzverband Betonschalungen e.V.
PO-Box 10 44 61
40855 Ratingen
Germany

3 Overview

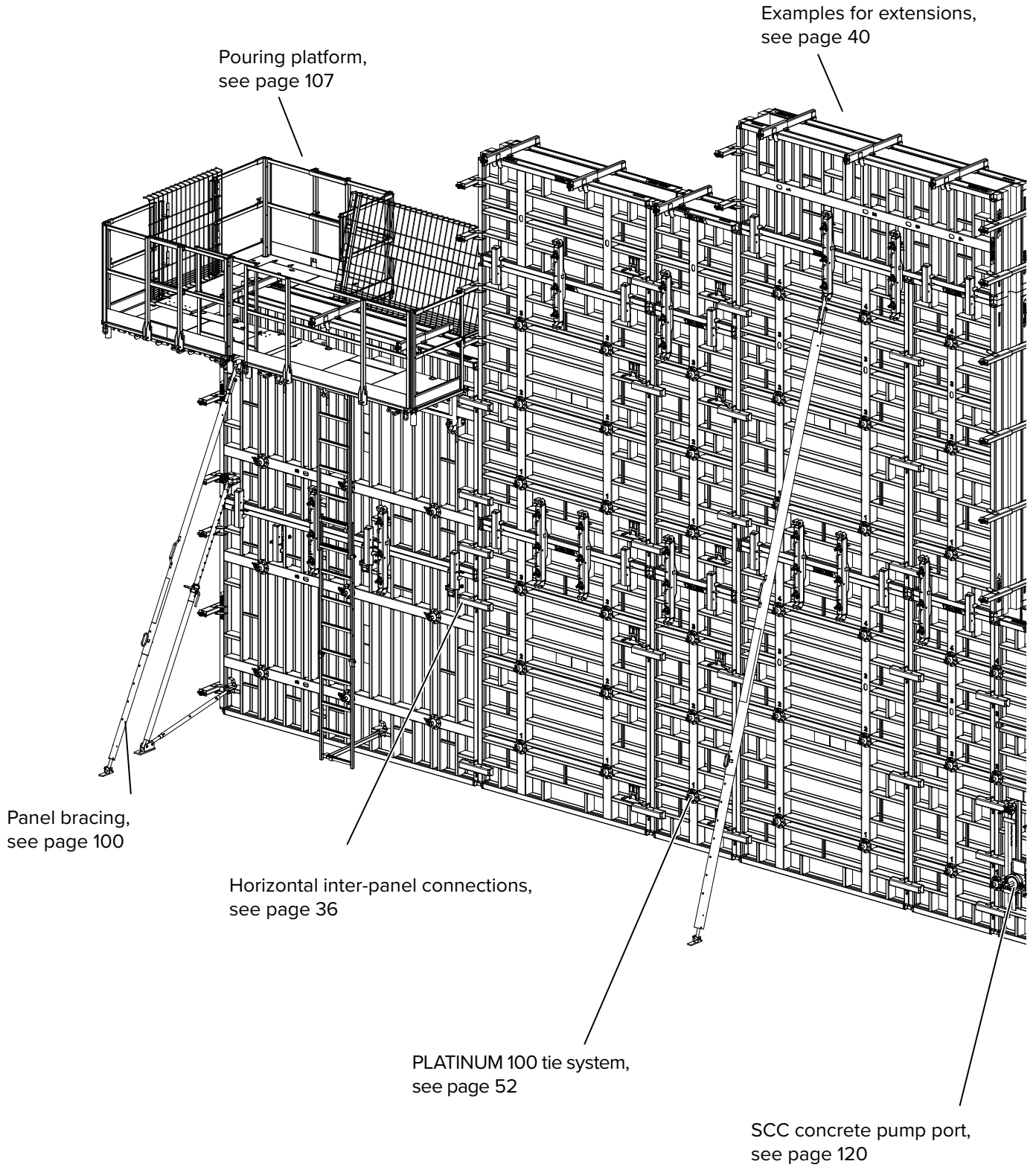

Shifting with a crane,
see page 112

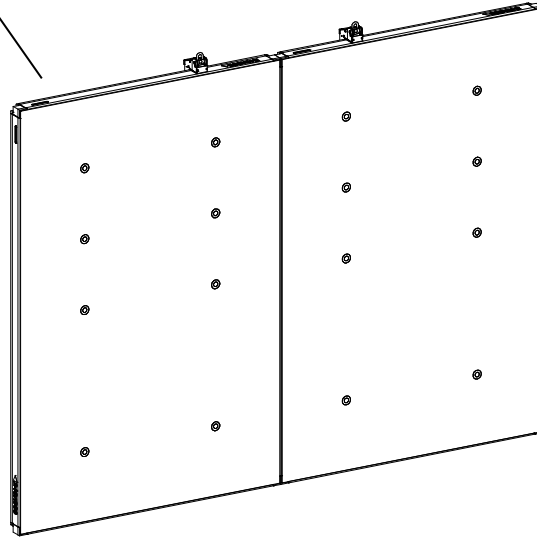

Bulkhead formwork,
see page 89

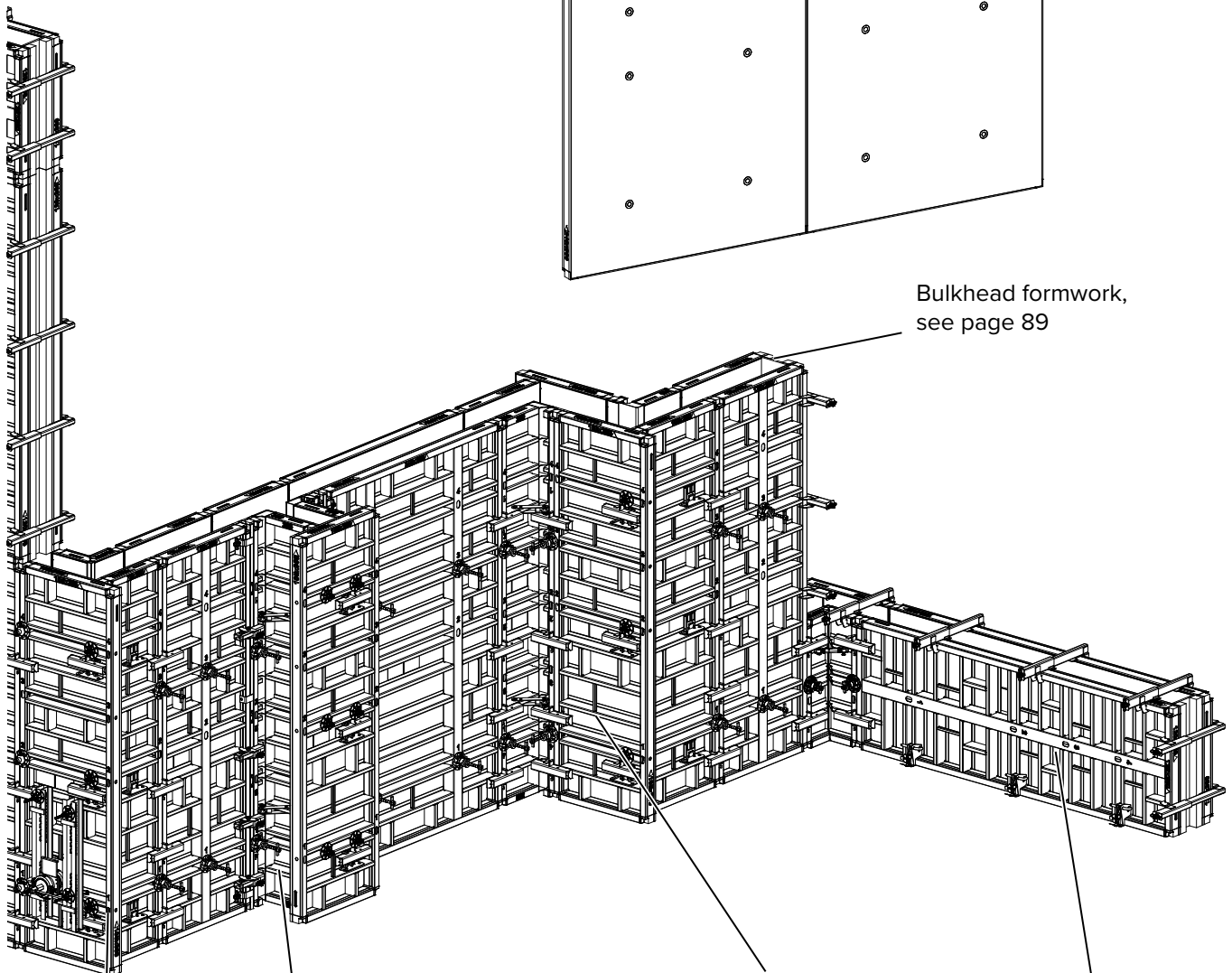

90° corners,
see page 72

Pilasters,
see page 81

Wall offsets,
see page 81

Foundation formwork,
see page 94

4 Components

4.1 PLATINUM 100 basic panels

The PLATINUM 100 panels with centered symmetrical tie locations at the inside of the panels allow forming of large and straight wall surfaces (see page 31).

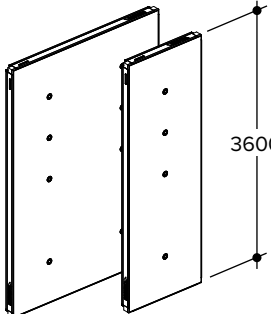
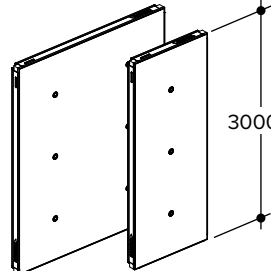
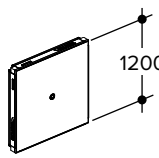
	Component	Product code	Weight [kg]
	PLATINUM 100 panel 240/360	604600	582.28
	PLATINUM 100 panel 120/360	604620	333.18
	PLATINUM 100 panel 240/300	604720	480.16
	PLATINUM 100 panel 120/300	604740	273.16
	PLATINUM 100 panel 120/120	604840	117.85

4.2 PLATINUM 100 panels with extra tie points in the edge profile

The PLATINUM 100 panels with extra tie points in the edge profile are equipped with symmetrical, internal tying points. Extra tie points towards the edges and horizontal holes allow for very economic forming of wall corners and wall offsets (see page 32).

	Component	Product code	Weight [kg]
	PLATINUM 100 panel 90/360	604640	287.24
	PLATINUM 100 panel 75/360	604660	209.79
	PLATINUM 100 panel 60/360	604680	183.47
	PLATINUM 100 panel 45/360	604700	124.40

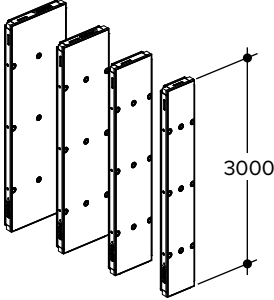
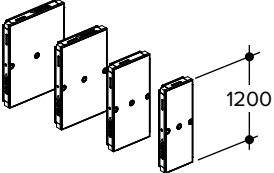
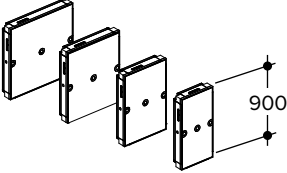
	Component	Product code	Weight [kg]
	PLATINUM 100 panel 90/300	604760	231.18
	PLATINUM 100 panel 75/300	604780	170.10
	PLATINUM 100 panel 60/300	604800	148.36
	PLATINUM 100 panel 45/300	604820	103.46
	PLATINUM 100 panel 90/120	604860	98.20
	PLATINUM 100 panel 75/120	604880	74.65
	PLATINUM 100 panel 60/120	604900	65.65
	PLATINUM 100 panel 45/120	604920	44.60
	PLATINUM 100 panel 90/90	604940	61.50
	PLATINUM 100 panel 75/90	604960	52.29
	PLATINUM 100 panel 60/90	604980	46.32
	PLATINUM 100 panel 45/90	605000	37.49

4.3 Extension panels

The PLATINUM 100 extension panels complement the PLATINUM 100 panel program. They create a continuous panel-joint pattern when combined vertically and horizontally and when used horizontally with 240 cm wide PLATINUM 100 panels (see page 40 forward).

NOTE

Note!

The extension panels can also be used at the bottom for very economic forming..

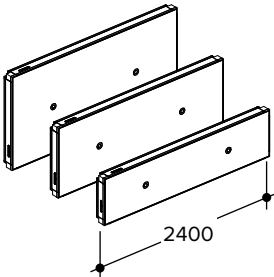
	Component	Product code	Weight [kg]
	PLATINUM 100 panel 240/120	605540	208.00
	PLATINUM 100 panel 240/90	605530	145.35
	PLATINUM 100 panel 240/60	605550	106.64

4.4 Multipurpose panels (MP)

The PLATINUM 100 multipurpose panels are equipped with multipurpose ribs (MP ribs), horizontal cross holes in the edge profiles and tie holes all at the same elevation. This allows to tie a standard PLATINUM 100 panel directly in an opposing MP panel and to construct 90° corners (see page 33).

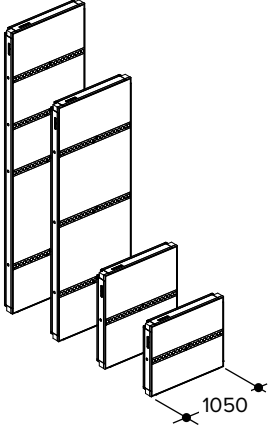
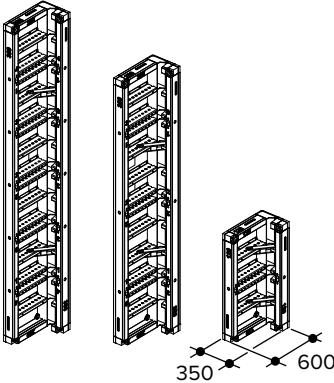
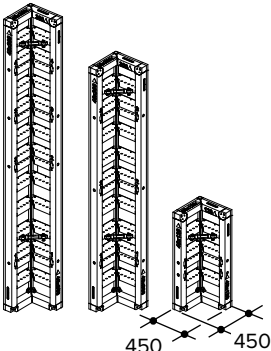
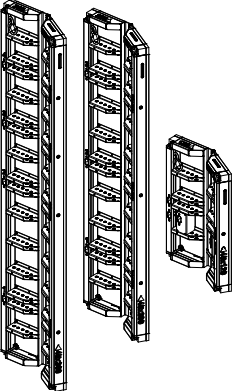
	Component	Product code	Weight [kg]	
	PLATINUM 100 MP panel 105/360	605020	318.06	
	PLATINUM 100 MP panel 105/300	605040	256.12	
	PLATINUM 100 MP panel 105/120	605060	108.32	
	PLATINUM 100 MP panel 105/90	605080	87.24	
	PLATINUM 100 MP inside corner 35/60/360	605400	279.14	
	PLATINUM 100 MP inside corner 35/60/300	605420	220.15	
	PLATINUM 100 MP inside corner 35/60/120	605440	93.43	
<p>The PLATINUM 100 MP inside corners are equipped with MP ribs, horizontal cross holes and tie points at equal heights as well as stripping joints. The PLATINUM 100 MP inside corners are a very economical solution for forming bulkheads, pilasters and wall offsets in 5 cm steps (see page 81).</p>		PLATINUM 100 inside corner 90° 45/45/360	605100	195.58
PLATINUM 100 inside corner 90° 45/45/300		605120	163.25	
PLATINUM 100 inside corner 90° 45/45/120		605140	71.31	
<p>The PLATINUM 100 inside corners 90° are equipped with a 2.5° stripping release, a unique quick-release mechanism and spindles for fine adjustment. The spindles are equipped with a marking at 90° (see page 72 forward).</p>		PLATINUM 100 inner hinged corner 45/360	605160	213.25
PLATINUM 100 inner hinged corner 45/300		605180	178.80	
PLATINUM 100 inner hinged corner 45/120		605200	81,00	
<p>Flexible corner panel for inner corners with angles from 75° to 165°. The lateral side length is 35 cm.</p> <p>Corners with less than 90° are connected with panel clamps (see page 76).</p>	12	Unless stated otherwise all dimensions are in mm		

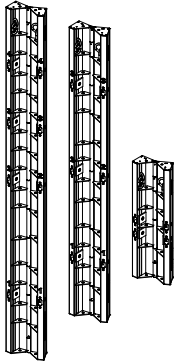
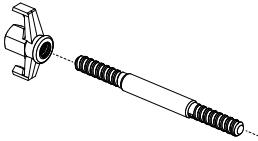
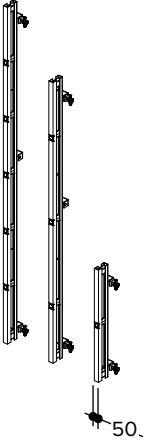
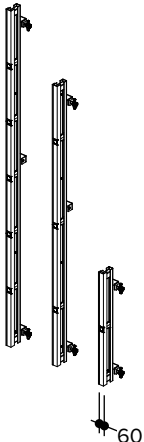
	Component	Product code	Weight [kg]
	PLATINUM 100 outer hinged corner 15/360	605280	127.91
	PLATINUM 100 outer hinged corner 15/300	605300	106.35
	PLATINUM 100 outer hinged corner 15/120	605320	46.93
	<p>To be applied as an outer corner for nonrectangular corners. The lateral side length is 10 cm. Also used in shaft formwork with hinged corners. Adjustable from 75° to 192° (see page 76).</p>		
	PLATINUM 100 connecting bolt outer hinged corner	605667	1.00
	PLATINUM 100 wing nut DW 20	605668	0.48
	PLATINUM 100 filler 5/360	605460	35.39
	PLATINUM 100 filler 5/300	605480	30.17
	PLATINUM 100 filler 5/120	605500	14.12
<p>The PLATINUM 100 fillers are used for length adjustments in 5 cm steps e.g. at corners (see page 66).</p>			
	PLATINUM 100 filler 6/360	605486	44.30
	PLATINUM 100 filler 6/300	605485	37.64
	PLATINUM 100 filler 6/120	605484	17.14
<p>The PLATINUM 100 fillers are used for length adjustments in 6 cm steps e.g. at corners (see page 66).</p>			

4.5 Lifting gears

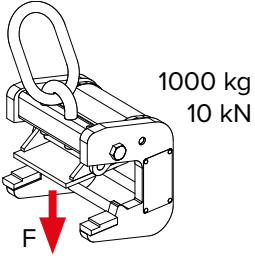
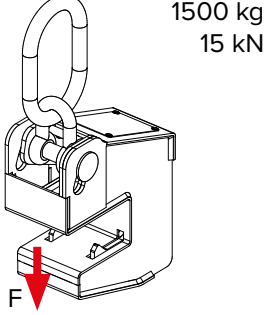
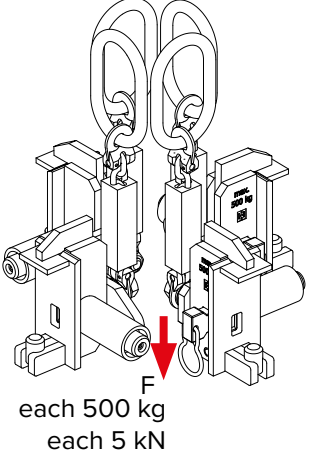

	Component	Product code	Weight [kg]
	PLATINUM 100 transport hook (see page 112) Permitted F: 1000 kg, 10 kN	604579	14.31
	PLATINUM 100 transport hook plus (see page 114) Permitted F: 1500 kg, 15 kN	606225	9.78
	Set of 4 pcs. PLATINUM 100 lifting gear For loading and unloading of panel bundles. Scope of delivery: 4 pcs. Permitted F: 500 kg, 5 kN (each)	605511	17.04

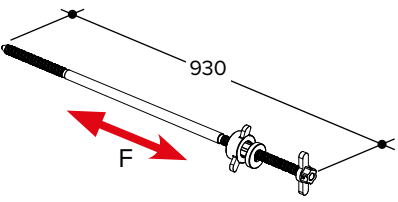

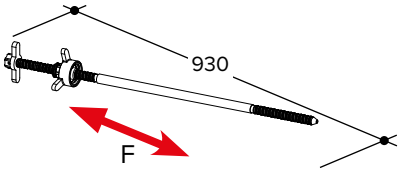
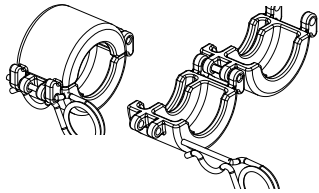
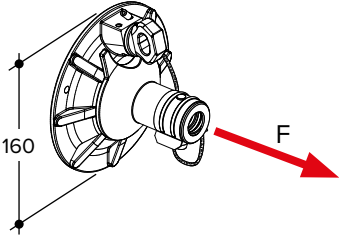
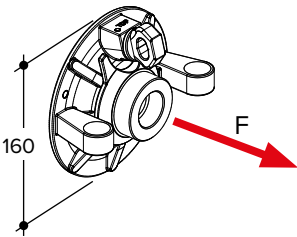
4.6 Tie rod

	Component	Product code	Weight [kg]
	PLATINUM 100 tie rod G1 The PLATINUM 100 tie rod, combined with the PLATINUM tie nut advancing side and the PLATINUM tie nut closing side, provides a very quick and easy system to close the formwork. The PLATINUM 100 tie rod can be operated from one side only (see page 52 forward). Permitted F: 150 kN	604300	4.11

	Component	Product code	Weight [kg]
	<p>PLATINUM 100 tie rod G2</p> <p>The PLATINUM 100 tie rod, combined with the PLATINUM tie nut advancing side and the PLATINUM tie nut closing side, provides a very quick and easy system to close the formwork. The PLATINUM 100 tie rod can be operated from one side only (see page 52 forward).</p> <p>Must be used with PLATINUM 100 adjustment clip.</p> <p>Zulässig F: 150 kN</p>	606340	3.90
	<p>PLATINUM 100 adjustment clip for tie rod G2</p> <p>Is used to adjust the wall thickness at PLATINUM 100 tie rod G2.</p>	604021	0.43
	<p>PLATINUM 100 tie nut advancing side</p> <p>Permitted F: 150 kN</p>	604196	2.79
	<p>PLATINUM 100 tie nut closing side</p> <p>Permitted F: 150 kN</p>	604197	2.65

4.7 Plugs

	Component	Product	Weight [kg]
	<p>100 pcs. PLATINUM 100 closing plugs</p> <p>Standard plug with a flush finish, used to close the tie holes that are not used (see page 52).</p>	604590	0.50
	<p>100 pcs. PLATINUM 100 sealing cones</p> <p>Used for sealing the tie holes when using the PLATINUM 100 tie rod (see page 52 forward).</p>	604595	0.50

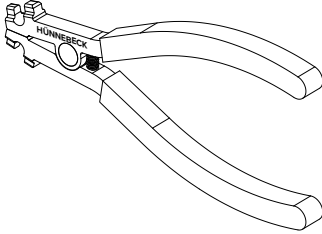
	Component	Product	Weight [kg]
	100 pcs. PLATINUM 100 universal flat rings This insert is used with standard DW 20 tie rods with PLATINUM 100 thru tube cones and thru tubes (see page 52 forward).	604597	0.30
	100 pcs. PLATINUM 100 thru tube cones, 26 mm Used to seal the thru tubes when using standard DW 20 tie rods with PLATINUM 100 universal flat plugs. The imprint in the concrete is the same as the one from the PLATINUM 100 sealing cones (see page 52).	604599	0.30
	100 pcs. PLATINUM 100 dummy cones Used to achieve an architectural impression of a conical concrete imprint, which is equal to the imprint of the PLATINUM 100 sealing cone for tie points that are not used (see page 52 forward).	604698	0.70
	PLATINUM 100 cone gripper The PLATINUM 100 cone gripper allows an easy turning of the PLATINUM 100 sealing cones and PLATINUM 100 universal flat rings into the PLATINUM 100 formwork panels. It can also be used to break out the sealing cones and the universal flat rings from the PLATINUM 100 formwork panels (see page 54).	604659	0.21

4.8 Connection parts

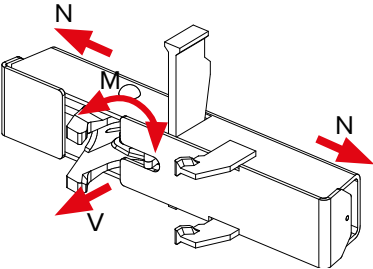
	Component	Product code	Weight [kg]
	PLATINUM aligning wedge clamp The PLATINUM aligning wedge clamp joins in one operation the PLATINUM 100 panels with a neat, tight and aligned fit in horizontally and vertically arranged panel combinations (see page 36). Permitted M: 1.9 kNm Permitted N: 21.0 kN Permitted V: 21.0 kN	605670	6.33

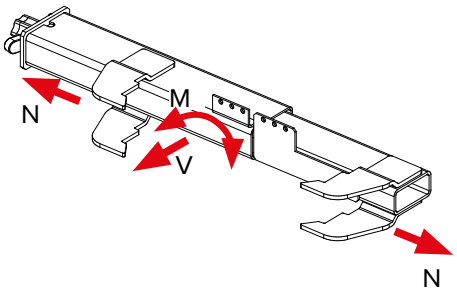
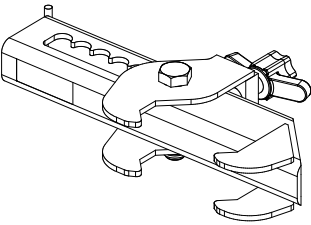
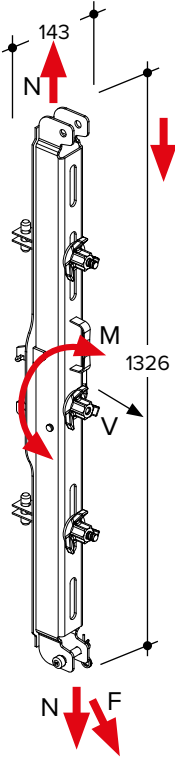
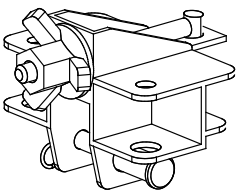
	Component	Product code	Weight [kg]
	<p>PLATINUM 100 bulkhead clamp</p> <p>The bulkhead clamp is used to support the bulkhead formwork in combination with square timbers and plywood, as well as an additional dry tie at the end of the wall without additional loose parts (see page 91 forward). The bulkhead clamp can also be used as a dry top tie for walls or foundation formwork (see page 94 forward).</p> <p>Permitted M: 5.0 kNm Permitted N: 36.0 kN Permitted V: 36.0 kN</p>	<p>604328</p>	<p>11.02</p>
	<p>PLATINUM 100 universal connector</p> <p>To connect PLATINUM 100 panels at adjustments and for the connection of corner panels (see page 65).</p> <p>Permitted N: 20.0 kN Permitted V: 20.0 kN</p>	<p>606209</p>	<p>6.33</p>
	<p>PLATINUM 100 MANTO extension bar</p> <p>The PLATINUM 100 MANTO extension bar is used to extend PLATINUM 100 panels (see page 42).</p> <p>Extended panels are connected safely at the panel joint and are aligned that way. Additionally alignment struts can be connected directly to the extension bar (see page 101).</p> <p>Permitted M: 7.0 kNm Permitted N: 21.0 kN Permitted V: 16.65 kN Permitted F_{strut}: 18.5 kN</p>	<p>607000</p>	<p>18.83</p>
	<p>Strut head</p> <p>Is used to connect the adapter for alignment struts and the wall struts to the PLATINUM panels. Applicable to formwork heights up to 3.90 m.</p>	<p>600035</p>	<p>4.33</p>

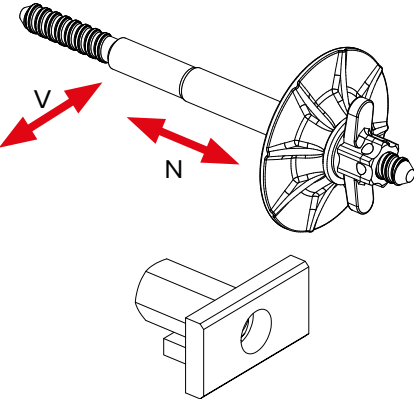
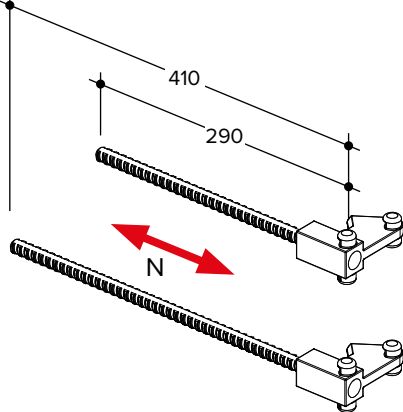
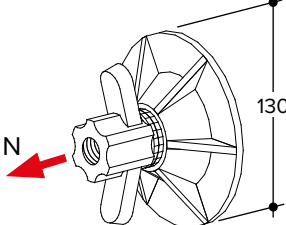
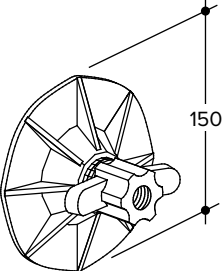
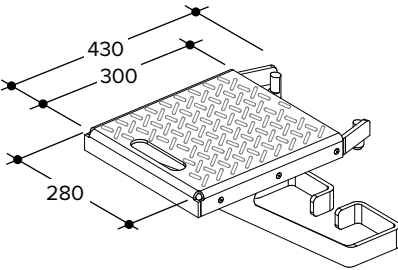
	Component	Product code	Weight [kg]
	<p>PLATINUM 100 MP bolt cpl.</p> <p>PLATINUM 100 MP nut</p> <p>The PLATINUM 100 MP bolt cpl. consists of the MP bolt and tie rod nut 150. This assembly is used to connect PLATINUM 100 MP panels together, e.g. for columns, when joining PLATINUM 100 MP panels with PLATINUM 100 panels with edge tie holes for outside corners and bulkheads. It always has to be used together with the PLATINUM 100 MP nut (see page 73).</p> <p>Permitted N: 66.0 kN Permitted V: 66.0 kN</p>	<p>605645</p> <p>605649</p>	<p>2.90</p> <p>0.91</p>
	<p>PLATINUM 100 multi bolt DW15/29</p> <p>PLATINUM 100 multi bolt DW15/41</p> <p>The PLATINUM 100 multi bolt is used to connect walers at bulkheads, at length adjustments and at stacked panel assemblies. It is used in combination with the MANTO tie nut (prod. code 464600, see page 67).</p> <p>Permitted N: 40.0 kN</p>	<p>605820</p> <p>605810</p>	<p>1.35</p> <p>1.52</p>
	<p>MANTO tie nut (DW15)</p> <p>Is used together with the multi bolt.</p> <p>Permitted N: 90.0 kN</p>	<p>464600</p>	<p>1.26</p>
	<p>Tie nut 150 (DW 20)</p> <p>Tie nut for tie rods DW 20. Easy to unfasten.</p> <p>Permitted load: 150.0 kN</p>	<p>531481</p>	<p>1.51</p>
	<p>PLATINUM 100 platform step</p> <p>The PLATINUM 100 platform step is used to reach parts that are placed in higher position. Max. perm. fall height: 1.0 m (see page 104).</p> <p>Permitted load: 150 kg</p>	<p>606480</p>	<p>5.95</p>

4.9 Anchors

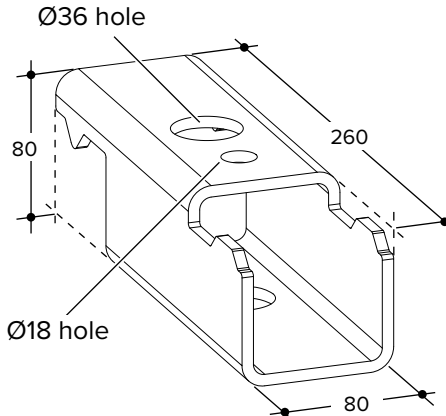
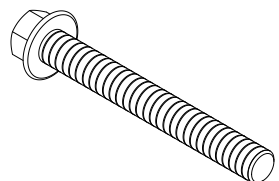
	Component	Product code	Weight [kg]
	<p>Panel Anchor Bracket</p> <p>The Panel Anchor Bracket is used to provide horizontal restraint to PLATINUM Panels.</p> <p>The bracket has 2no. Ø18 holes on opposite sides (one hole not visible), for locating the anchor. The larger Ø36 holes are placed to allow the spanner extension to pass through.</p>	605999	2.27
	<p>Anchor Bolt MM+SSK 16 x 130</p> <p>Used to temporarily secure the Panel Anchor Bracket to the existing structure. Only one bolt is required per bracket.</p>	443500	0.21

4.10 PLATINUM 100 SCC concrete pump port

The PLATINUM 100 SCC concrete pump port is designed for Ø12.5 cm hoses. It can be used with 90 cm wide panels as well as every MP panel and allows to pump fresh concrete into the closed formwork (see page 120).

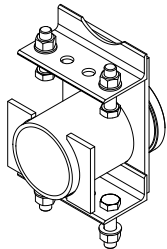
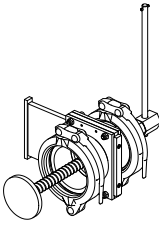
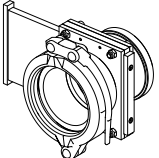
	Component	Product code	Weight [kg]
	<p>SCC panel connection PLATINUM DN125</p> <p>The SCC panel connection is used to connect the SCC closing unit to the PLATINUM 100 panel. It transfers the resulting forces from pumping the concrete into the PLATINUM 100 panel (see page 120).</p>	605830	13.38
	<p>SCC closing unit DN 125 cpl.</p> <p>When using the SCC closing unit DN 125 cpl., the formwork can be closed with the SCC shutter after pumping the concrete into the form and before removing the concrete pump hose. After removing the hose, the extra concrete will be pushed flush out of the SCC panel connection and into the wall using the spindle assembly (see page 121).</p>	605843	31.19
	<p>SCC hose shutter unit DN 125</p> <p>In addition, the SCC hose shutter unit DN 125 can be connected to the hose of the concrete pump to prevent loss of the concrete before switching to the next SCC concrete pump port (see page 122).</p>	605844	18.42

5 Details of the PLATINUM 100 formwork

The following pages explain the features of the PLATINUM 100 formwork.

5.1 Load bearing capacity

A high load bearing capacity of up to 100 kN/m² is achieved.

- Permitted fresh concrete pressure: 100 kN/m², full surface load according to DIN 18218.
- Compliance with the flatness requirements of DIN 18202 table 3, row 7.
- Use of the PLATINUM 100 tie system or DW 20 ties.

Full utilization of the load capacity of the ties due to tie arrangements in accordance with the fresh concrete pressure.

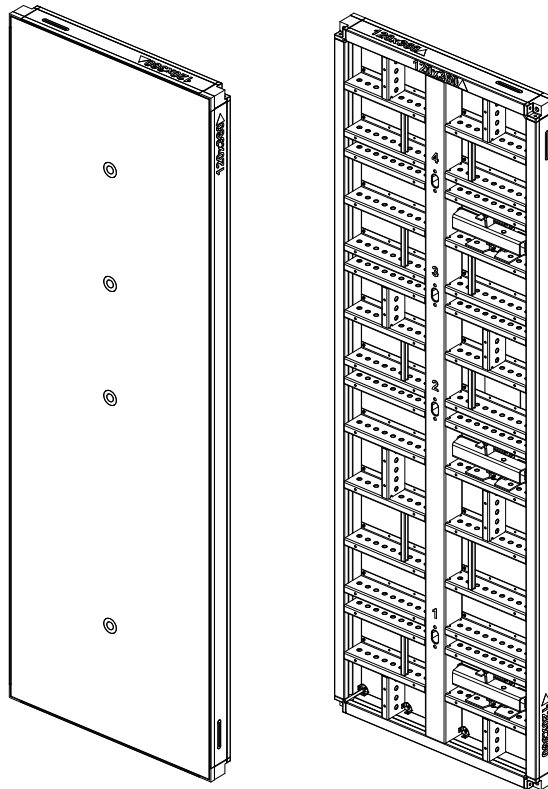

5.2 Concrete surface

High-quality concrete surface results with the ECOPLY full plastic composite form sheet

PLATINUM 100 achieves a high-quality concrete surface thanks to the 15 mm thick ECOPLY full plastic form sheet. The ECOPLY full plastic panel was especially developed for PLATINUM 100 and consists of a multilayer plastic composite system.

- Remarkable high-quality concrete surfaces without marks from rivets or screws even with the 240 cm wide PLATINUM 100 basic panels.
- Extra long-life due to the robust plastic surface on the concrete side.
- Low water absorption and therefore no delamination caused by swelling or shrinking due to water.
- Holding forces of nails equal to those used with high-quality plywood.

- Excellent for use with nails even in cold temperatures.
- Fewer use of release agents, easy to clean and easy to repair with proven methods.
- Suitable for high-quality exposed concrete.
- No delamination of the face-layer of the formsheet due to water.

Form sheet concrete side

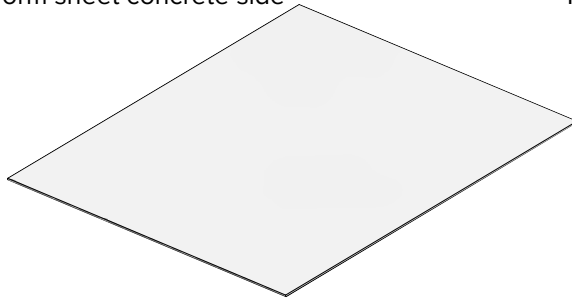

Form sheet back side

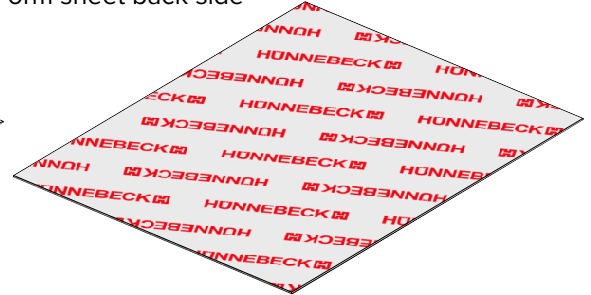

5.3 Steel frame

Strong, galvanized steel frame

- Robust, rigid 14 cm deep steel frame.
- Galvanized inside and outside for long lifetime.
- Connection groove on all four sides of the panel allow flexible connections in all directions.
- Circumferential edge profiles protect the edges of the form sheet in all directions.
- Circumferential silicone sealing.
- Closed frame openings in tie holes and cross holes to prevent the leakage of fresh concrete into the hollow frame profiles.
- Panel ribs are equipped with hole for various connections of accessories in a continuous grid of 5 cm.

Detail of tie hole and cross hole at edge profile

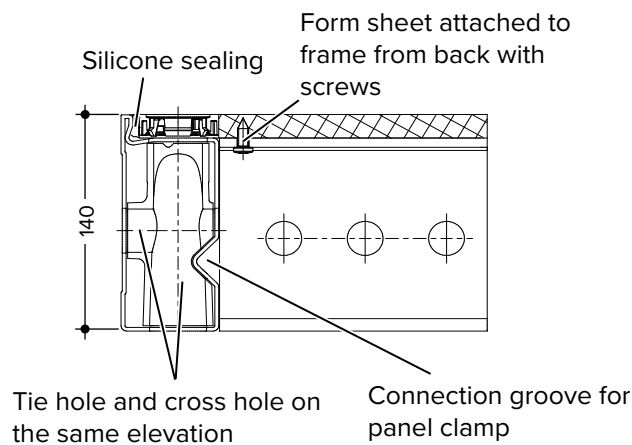

5.4 Tie hole

- Robust, welded and fully galvanized tie sleeves.
- Conical tie sleeves for easy tie insertion, flexible tie angles and easy removal of concrete residues.
- The flush integrated, hard plastic inserts reinforce the high-stress areas around the tie holes and minimize wear on the panel to ensure a long product life.

Detail of tie hole at main inner profile

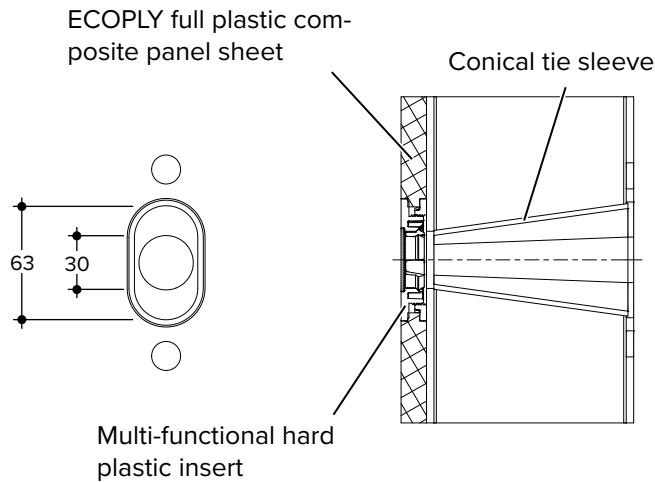
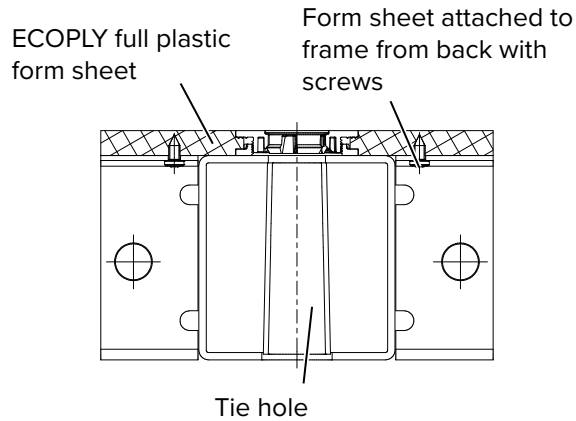

5.5 Frame corner

Innovative, robust frame corners

- Robust corner castings completely joined with welds to the edge profiles to minimize damage to the corners, e.g. due to collision.
- Practical lever point in each corner for accurate positioning of upright and lying panels in the direction of the panel and vertical to the panels.
- Openings to connect the PLATINUM 100 lifting gear.

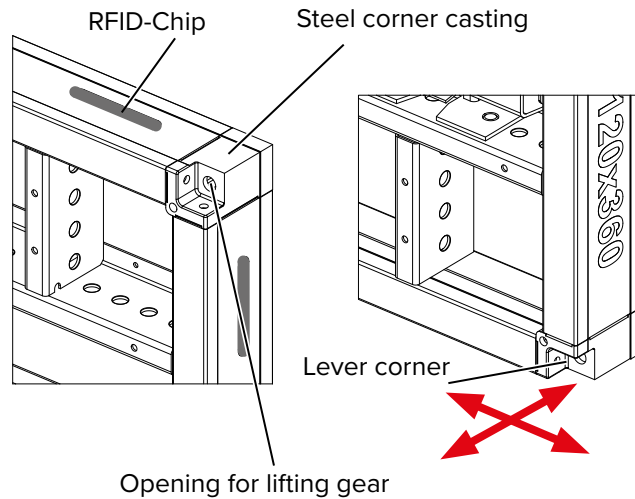

5.6 RFID technology

Integrated RFID technology

- Innovative RFID transponders (RFID = radio frequency identification) with read and write capability, used to individualize and identify the panels for use with automatic detection systems, e.g. for leasing and life cycle management.
- RFID transponders in protected locations for a reliable, long, useful life without battery.

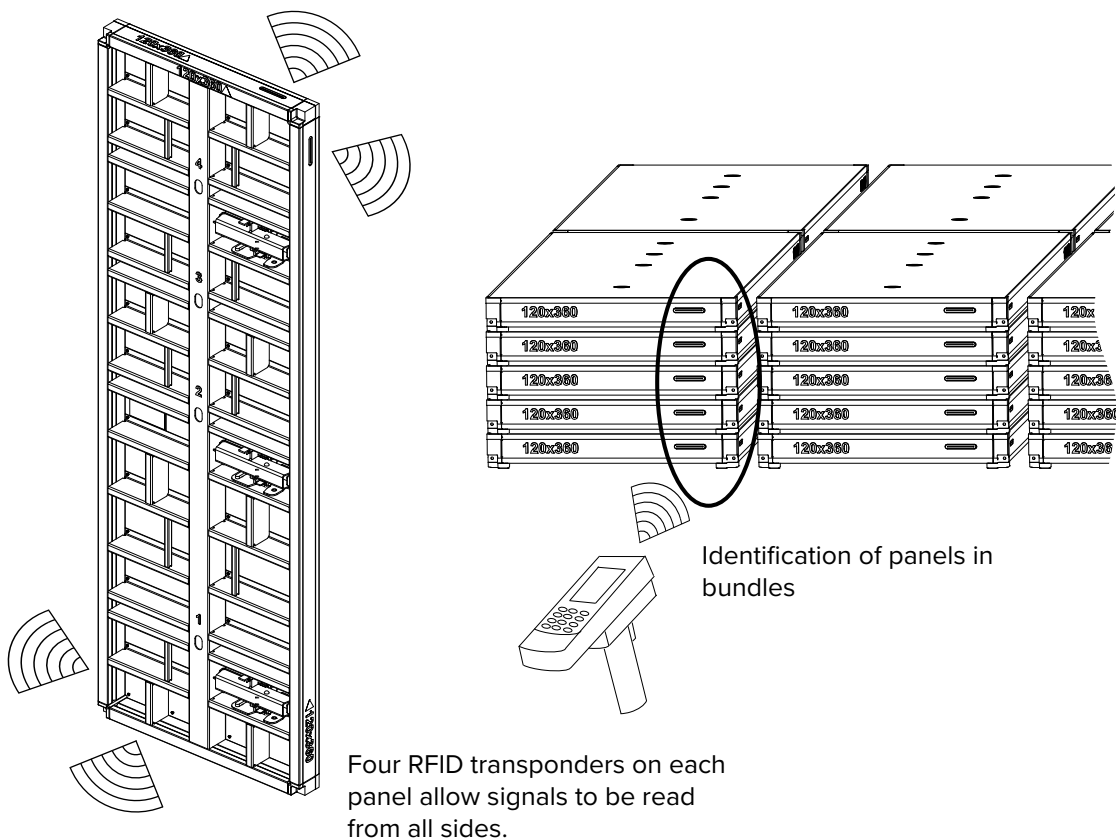

5.7 Handles

- They simplify handling during the assembly of the panels.

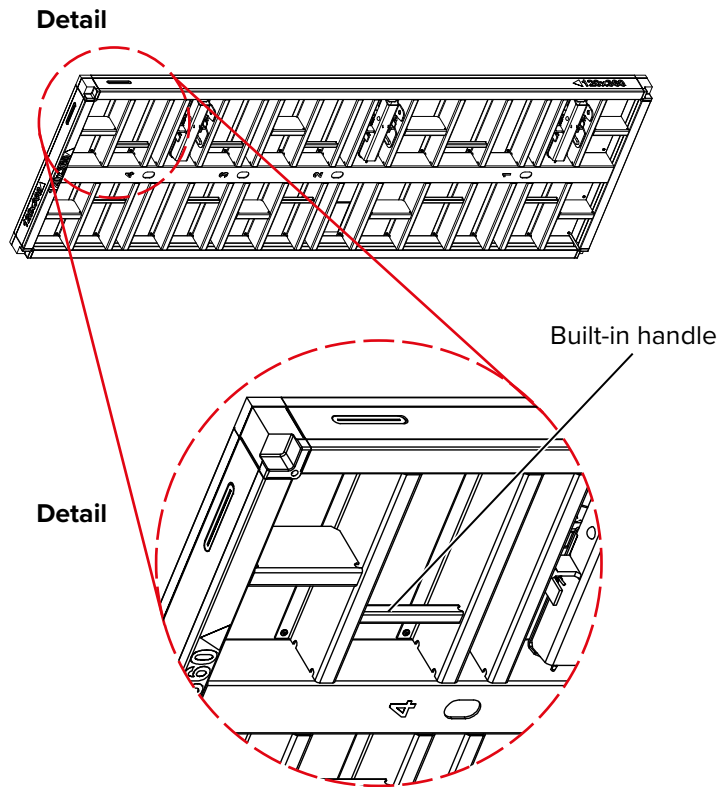

WARNING

Warning!

Do not use the built-in handles to transport the panel with a crane or for climbing the panels!

5.8 Labels

Easily understandable panel labeling

- Clear identification of size and orientation on all sides of the panel for efficient handling. The labels show the panel sizes (width × length) in cm and triangular arrows point towards the direction of the top of the panel.
- Stickers with practical operating instructions for the tie arrangement inform the user with high visibility colors. The numbering of the tie holes supports the site personnel in minimizing the number of tie rows.

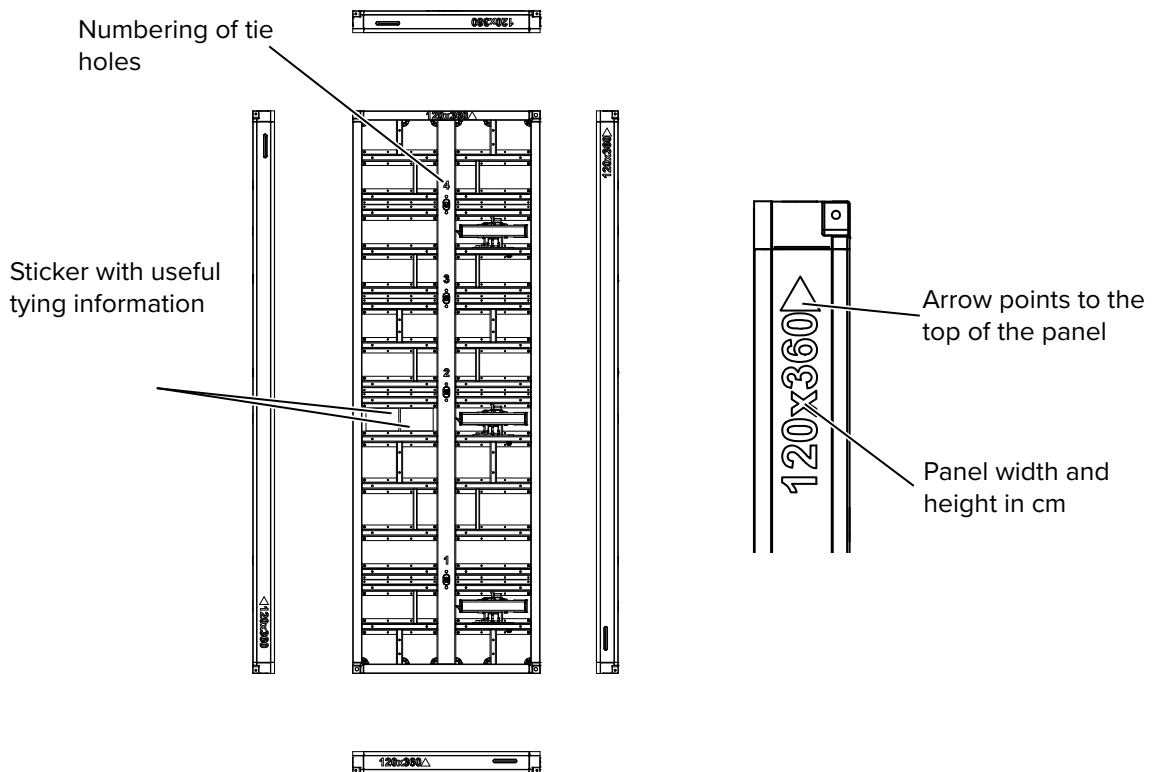

NOTE

Note!

Ensure that the panels stand the right way up to prevent problems when inserting the ties or the aligning wedge clamp. The panels stand up correctly when the labels are readable the right way up.

5.9 Bracket for PLATINUM aligning wedge clamp

The PLATINUM 100 panels are equipped with integrated brackets that hold the strong standard connection clamp directly in the panel frame. The PLATINUM aligning wedge clamps can be easily removed by hand. The PLATINUM 100 panels with a width of 60 cm and wider come with included PLATINUM aligning wedge clamps.

After removing the clamps from the brackets, the aligning wedge clamps still remain attached to the panel with a cable and can be positioned freely to join panels together. The cable also stops the clamp from falling when disconnecting upright panels.

Aligning wedge clamps that are correctly attached to the brackets in the panels do not project out of the panel frame. The clamp cannot automatically disengage itself during transport or storage. It is important that the clamp is correctly fitted to the bracket. The brackets are labeled with a highly visible red marking to give a visible confirmation that the clamp is correctly attached to the bracket.

The position and number of brackets meet the requirements of the typical horizontal connection between vertically arranged panels.

- The right number of horizontal panel connections at the right position in normal cases.
- Fewer loose parts on site.
- Reduced risk of injury by falling components when disassembling the formwork.

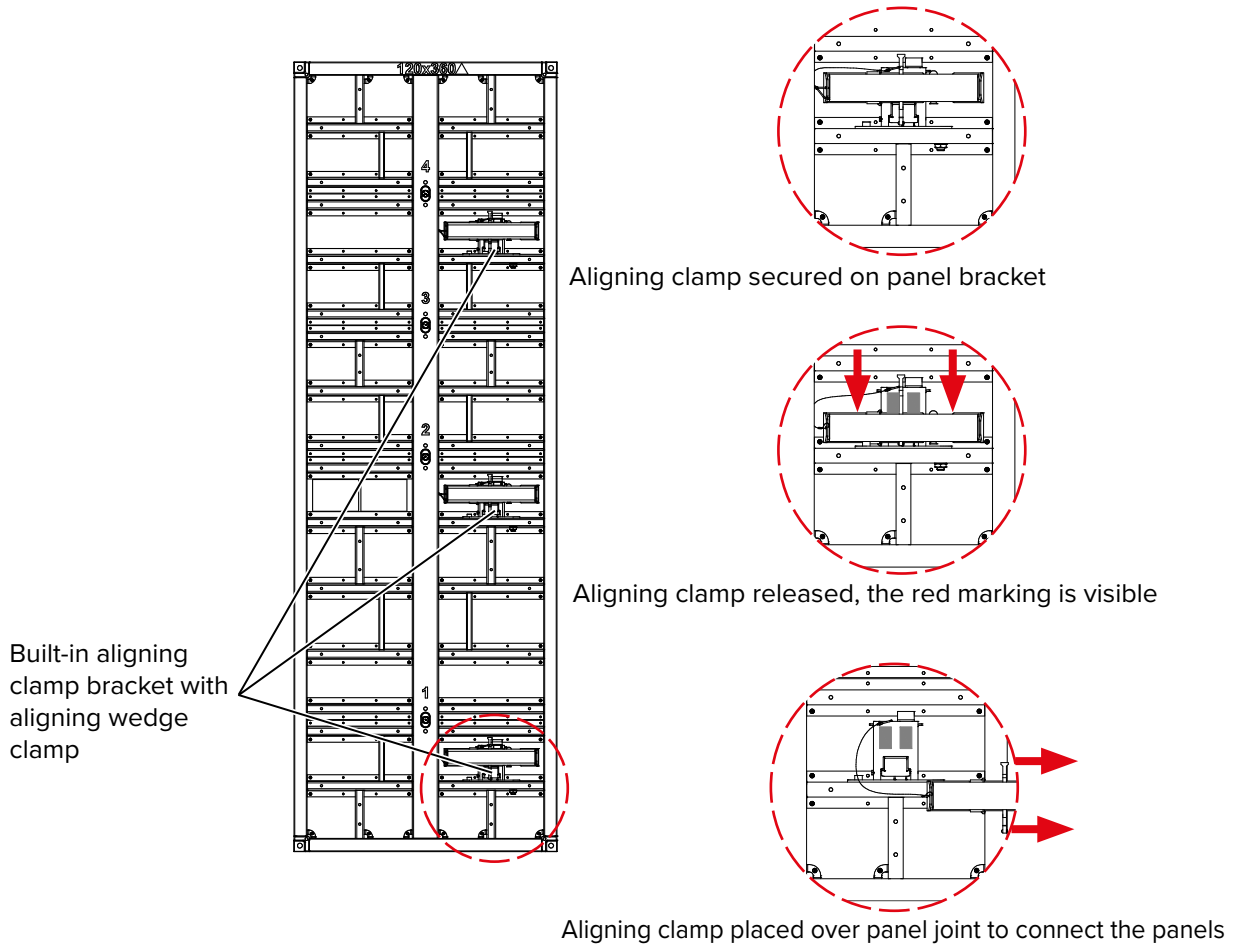

5.10 Connection options for accessories

Double shear holes in the panel ribs allow for higher connection forces. The hole diameter of 2.2 cm is suitable to accept standard bolts with a diameter of 2.0 cm. The holes in the ribs of the PLATINUM 100 panels have reinforced edges to provide optimal load transfer.

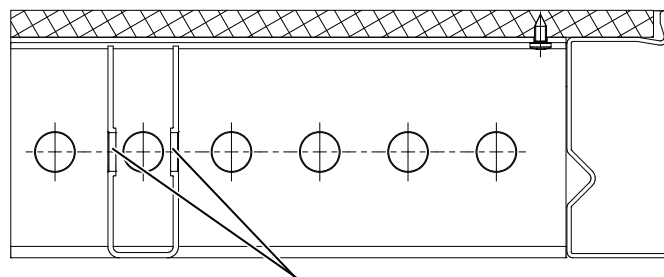

The continuous hole pattern with a spacing of 5.0 cm along the vertical and horizontal ribs of the panels ensures high flexibility for connecting accessories as well as an endless inter-panel hole pattern for connecting upright and lying panels in a 5 cm grid.

The hole pattern always begins at 10 cm from the panel edge.

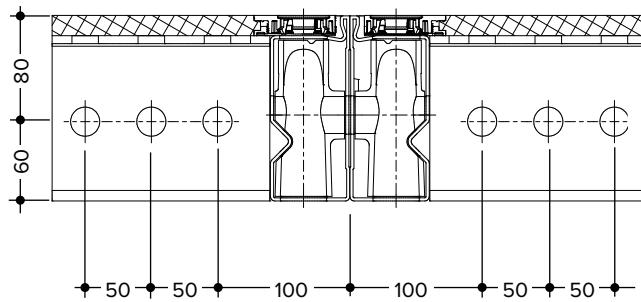

The distance from the axis of the panel ribs to the edge profiles and to each other is always 30 cm.

Bracing and walkway accessories can be attached in the same elevation on vertically or horizontally arranged panel assemblies.

Continuous hole pattern

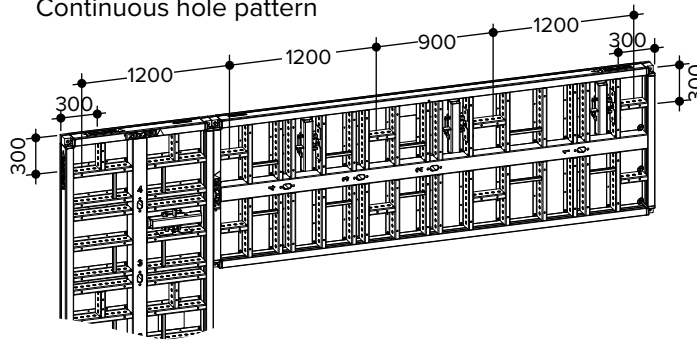

WARNING

Warning!

Deviations from the typical case may require additional panel connections, see chapter *Panel connections with increased tensile loads* on page 82!

6 Combinations and panel grid

6.1 Possible combinations

- PLATINUM 100 offers a consistent, optically appealing tie and joint pattern due to the symmetrically, centrally arranged tie holes and matching panel sizes
- Matching tie and joint pattern also in horizontal and upright panel combinations.
- Easy adaptation to building dimensions due to logical width and height increments of 15 cm between the PLATINUM 100 panels.

Upright combination

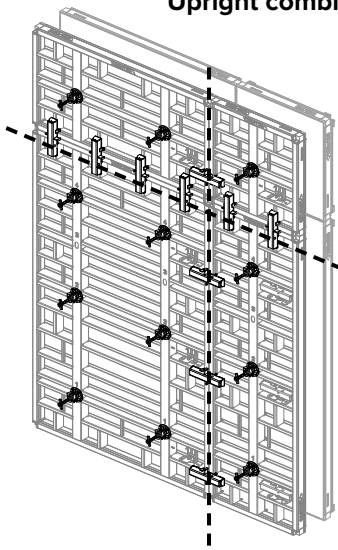

Combination of different upright arranged panels with regular tie pattern.

Horizontal combination

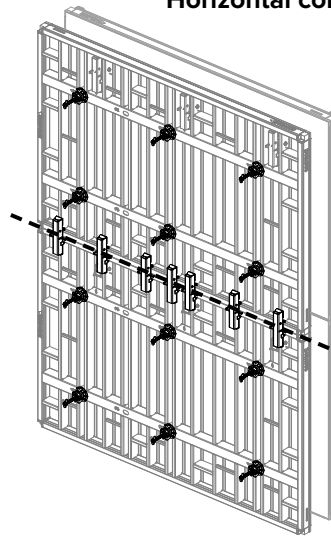

Combination of different horizontally arranged panels with regular tie pattern.

Upright and horizontal combination

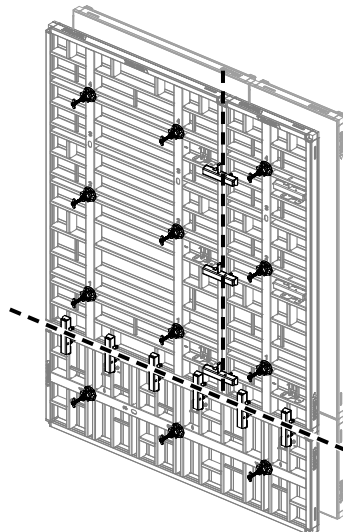

Combination of different upright and horizontally arranged panels with regular tie pattern.

6.2 Tie arrangement and fresh concrete pressure

The PLATINUM 100 system is designed for a fresh concrete pressure of 100 kN/m² as a constant load. However, the panels are used in many cases for pouring heights only up to their panel height of 360 or 300 cm without using extension panels. This results in a smaller, triangular hydrostatic load. PLATINUM 100 panels offers for those typical cases 360 and 300 cm high panels, which allow a reduction of the number of ties from three to two per panel without having to reduce the pouring speed.

NOTE

Note!

The requirements for the deflection with 100 kN/m² according to Line 7, table 3 DIN 18202 are met.

NOTE

Note!

When using not extended 300 cm elements with only one tie row and bulkhead clamps with on-site spreaders at full hydrostatic concrete pressure a flatness of the concrete surface according to DIN 18202, table 3, line 6 is met.

Stickers in highly visible colors with instructions for the tie arrangement and numbered tie holes support the user at minimizing the amount of necessary ties. It is also possible to achieve a symmetrical vertical tie pattern at pour heights under 360 and 300 cm by choosing the appropriate symmetrical tie arrangement.

Tie arrangement of a 360 cm PLATINUM 100 panel

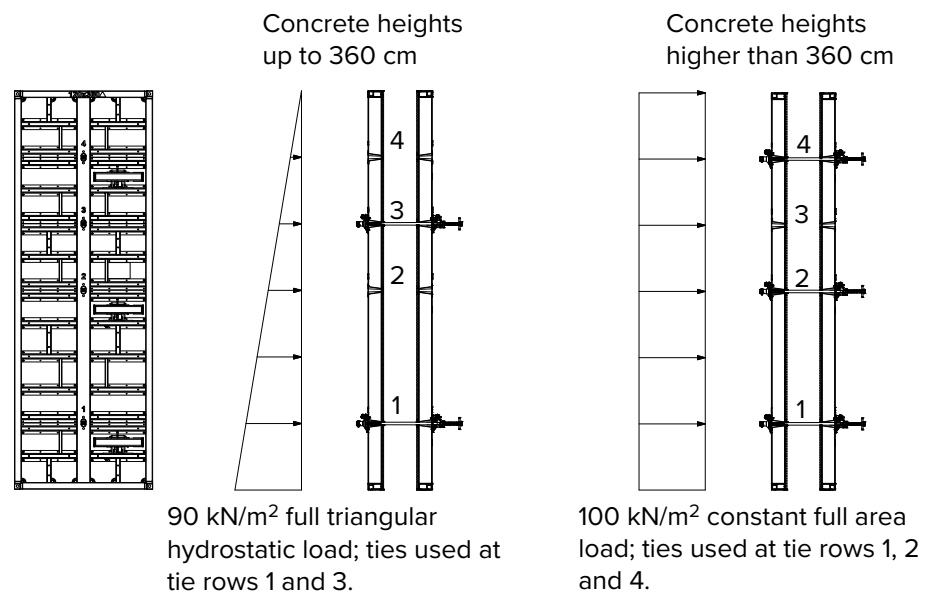

Tie arrangement of a 300 cm PLATINUM 100 panel

Concrete heights
up to 300 cm

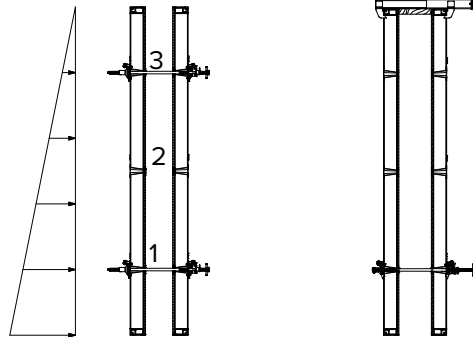

75 kN/m² full triangular hydrostatic load; ties used at tie rows 1 and 3 or ties at row 1 and with bulkhead clamp and spreader at the top of the panel.

Concrete heights
higher than 300 cm

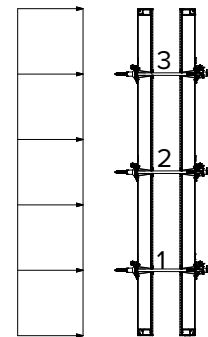

100 kN/m² constant full area load; ties used at tie rows 1, 2 and 3.

6.3 Tie arrangement with extension panels at the top

When using 300 or 360 cm high panels at the top of a high panel assembly these panels require only two tie rows.

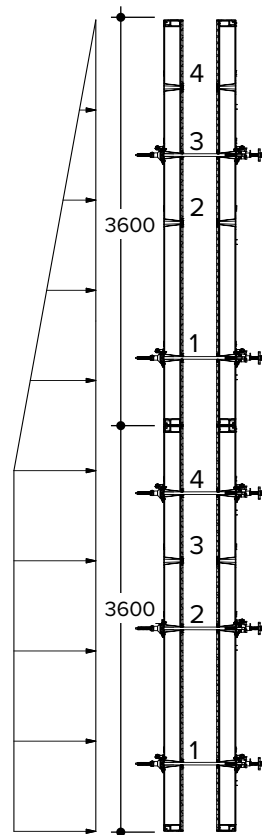

Extension up to 720 cm

2 ties in the upper panel
3 ties in the lower panel

Extension with 120 cm panel

1 tie in the upper 120 cm panel
3 ties in the lower 360 cm panel

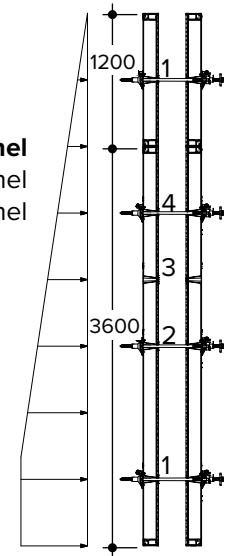

NOTE

Note!

The requirements for the deflection with 100 kN/m² according to line 7, table 3 DIN 18202 are met.

6.4 Tie arrangement with extension panels at the bottom

When the 120 cm panel is attached at the bottom, one tie row can be saved compared to the above shown extension at the top of a panel assembly.

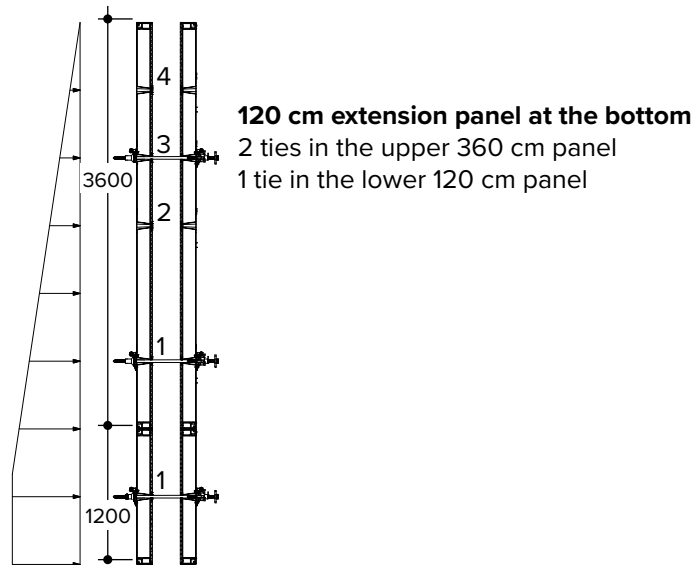

6.5 PLATINUM 100 basic panels

6.5.1 Panel widths

- The large PLATINUM 100 basic panels are especially efficient when forming large and flat wall surfaces.
- Centered, symmetrical tie locations.

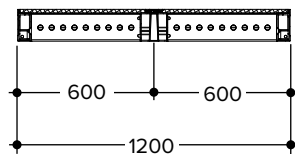
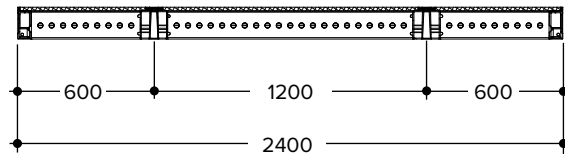

6.5.2 Panel heights

The 1st and 3rd tie row of the 360 cm high PLATINUM 100 panels are positioned at the same elevation as the 1st and 3rd tie row in the 300 cm high PLATINUM 100 panels allowing opposing 360 and 300 cm panels to be tied directly to each other without drilling.

Under hydrostatic concrete pressure it is not required to install ties in the 2nd tie row of opposing 300 and 360 cm high panels and the permitted concrete pressure does not need to be reduced.

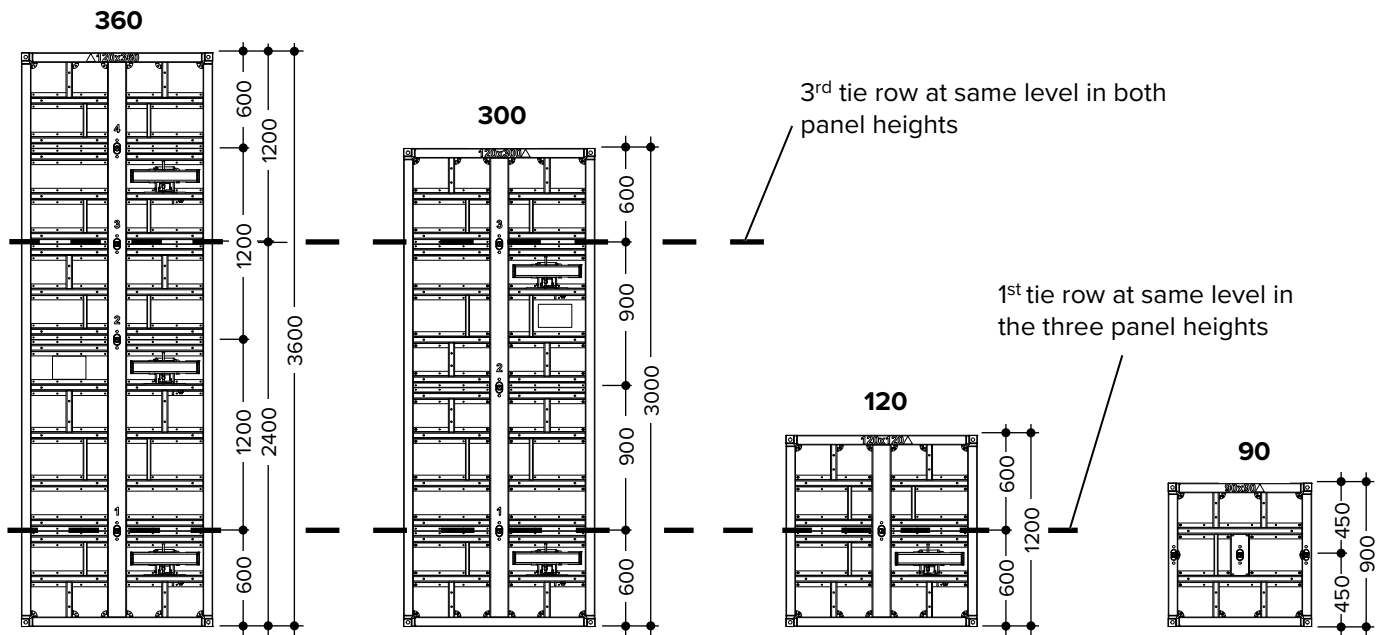

6.6 PLATINUM 100 panels with additional edge tie holes

The panels are available in different widths at 15 cm increments and have symmetrical tie points positioned along the center.

Additional tie holes are placed in the edge profiles of these panels allowing the forming of non-typical wall areas, e.g. in combination with the MP panels, in a simple and time-efficient manner.

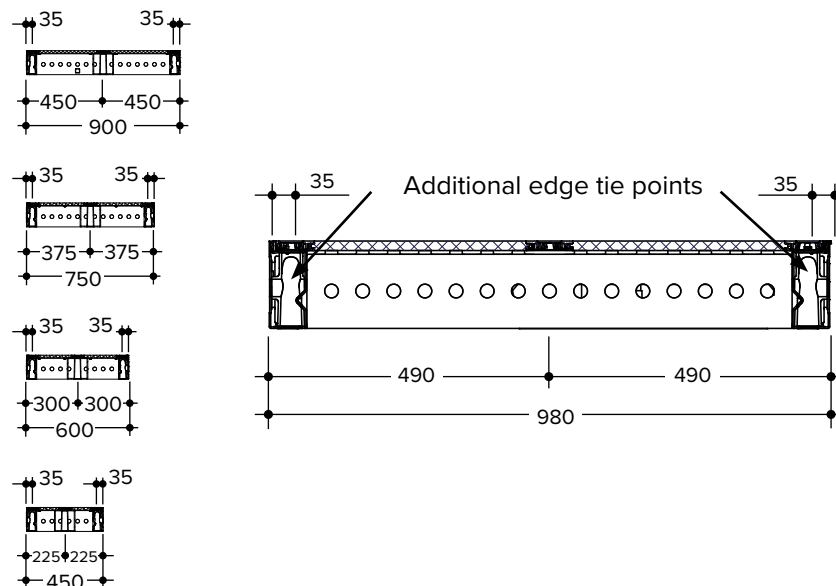

6.7 PLATINUM 100 multipurpose (MP) panels

The PLATINUM 100 MP panels and MP inside corners have been designed for simple and time saving forming of non-typical wall areas.

Length adjustments, T-intersections, outside corners, columns, bulkheads, pilasters and wall offsets can easily be formed with this type of panels.

The multipurpose panels are equipped with multipurpose ribs and cross holes in the edge profiles that are positioned at the same elevation as the standard tie locations. The multipurpose ribs allow placement of form ties and corner connections in 5 cm steps.

The additional tie row of the MP inside corner allows the use for a “right” corner and upside down as a “left” corner.

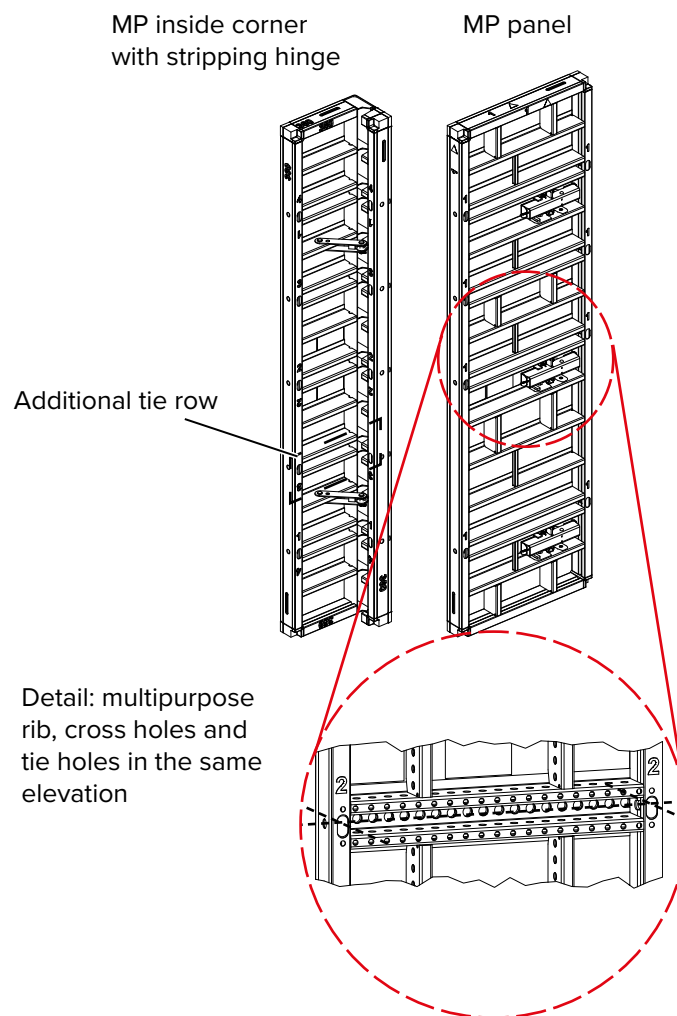

Since the multipurpose ribs and the tie locations are at the same elevation, the PLATINUM 100 panel can be tied directly to an opposing MP panel without having to drill in the valuable ECOPLY form sheets or without time consuming on-site, wooden infills.

Length adjustments (see also page 65 forward)

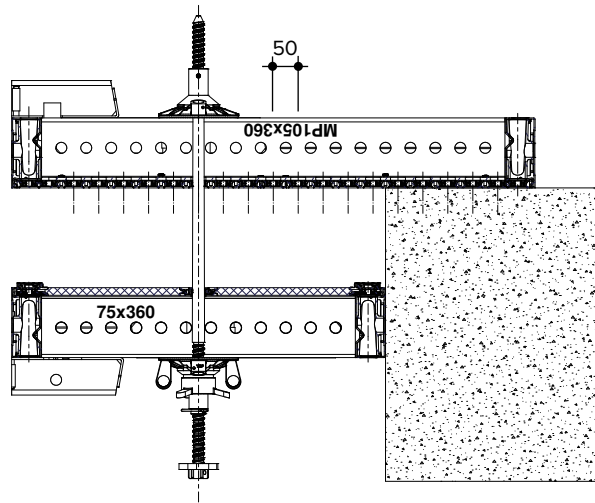

Because of the same elevation of the MP ribs and the edge tie holes the PLATINUM 100 MP bolt can be used to connect the MP ribs to the cross holes under 90° angle, providing a quick and strong system connection for outside corners, columns, bulkheads, wall offsets, pilasters and other non-typical areas.

Due to the placement of cross holes, multipurpose ribs and tie holes all at the same elevation, a huge variety of non-typical wall areas can be formed using the same panels. PLATINUM 100 does not require separate panels e.g. for outside corners and columns. In comparison to traditional wall-forming systems, this reduces the number of panels on site significantly, increases efficiency and equipment utilization and it simplifies the forming of special areas.

Corners (see also page 35 forward)

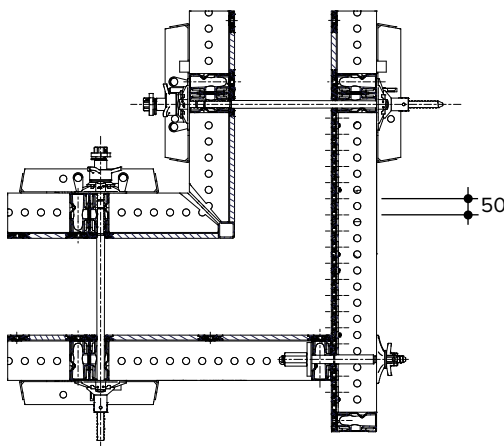

Windmill column (see also page 35 forward)

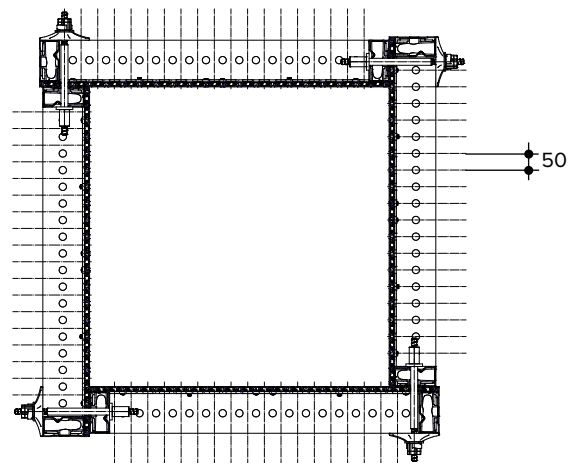

6.8 Panel overview

		Width [cm]											
		240	120	90	75	60	45	MP105	MP35x60	Inner corner	Inner hinged corner	Inner hinged corner	
Height [cm]	60												
	90												
	120												
	300												
	360												
		Basic panel without edge tie points			Elements with additional edge tie points								

7 Connection of panels

7.1 PLATINUM 100 aligning wedge clamp

The PLATINUM aligning wedge clamp is used for horizontal and vertical standard connections and achieves a neat, tight and self-aligned panel connection. PLATINUM 100 panels that are wider than 60 cm are equipped with brackets that hold the aligning wedge clamps required for most cases. Additional loose clamps complete the connections in non-typical areas such as panel connections with increased tensile loads, corners and vertical panel connections.

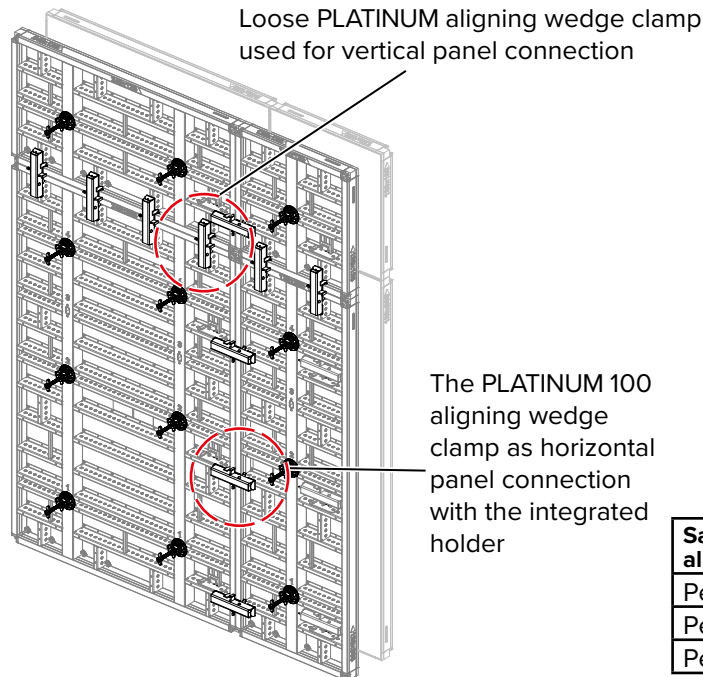

Save working loads of the aligning wedge clamp	
Permitted M	1.9 kNm
Permitted Z	21.0 kN
Permitted V	21.0 kN

The wedge of the aligning wedge clamp is operated with a hammer. It is equipped with double claws and an aligning profile. This achieves uniquely high connection stiffness, and even allows the lifting of stacked panel assemblies out of the horizontal position by crane often without the need for additional walers.

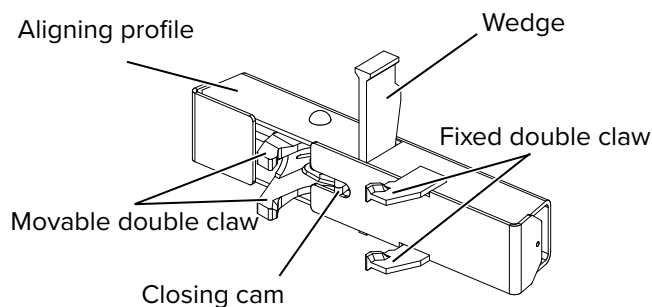

To release a closed clamp, the wedge must be hammered back out of the clamp. As soon as the wedge comes loose, the movable claw is directly secured in its open position with a loaded spring that keeps the wedge up and prevents unintended reclosing of the clamp.

All moving parts of the PLATINUM aligning wedge clamp are placed at the inside of the aligning profile to prevent damages and protect against concrete spills.

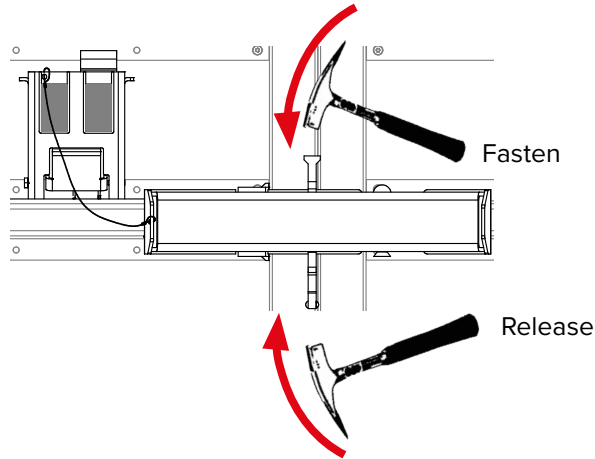

7.1 Removal of the aligning wedge clamp from the panel

To release an aligning wedge clamp that is secured in the panel, the release lever needs to be pulled towards the user. This unlocks the safety latch of the bracket and releases the aligning wedge clamp for use.

Release lever above the aligning wedge clamp

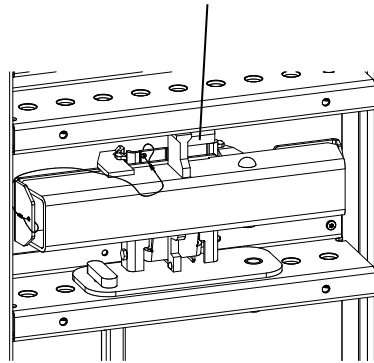

After removing the aligning wedge clamp from the panel joint, secure the clamp in the panel at its bracket before transporting or storing. The first step is to press the closing cam against the bracket until the movable claw closes around the bracket. Then the clamp must be pushed towards the red safety marking until the red area is no longer visible (covered by clamp) and the safety latch engages with an audible click.

Safety latch

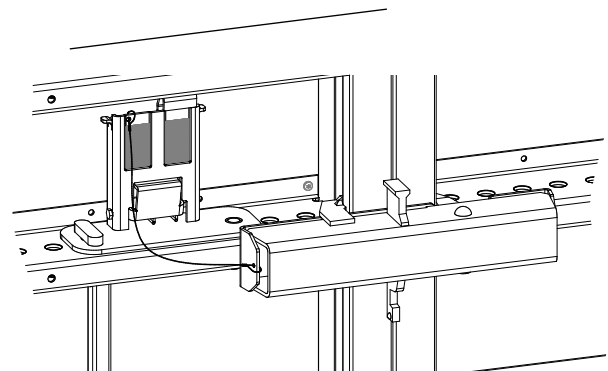
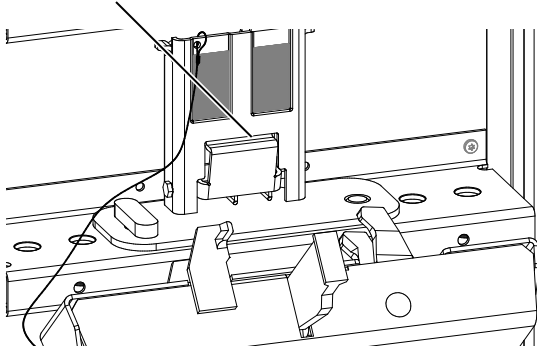

Aligning wedge clamp placed at panel joint

VISUAL CHECK

To prevent damage during transport, it is essential that the clamps are correctly secured to their brackets. This can be confirmed by checking that all red safety markings of the clamp brackets are completely covered by the clamps and that the safety latches are engaged.

7.2 Operation of the aligning wedge clamp

1. Lace the double claws of the aligning wedge clamp centrally over the panel ribs.
2. To secure the open clamp to the panel joint, press it towards the panel until the closing mechanism slides the claws into the grooves of the panel profile.

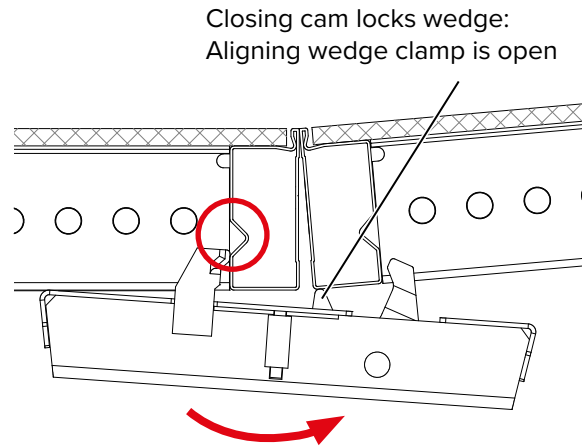

3. a) Clamps used horizontally: at standing panels the released wedge usually slides down due to gravity and closes the claws inside the grooves of the edge profile enough to hold it safely in place.
b) Clamps used vertically: The released wedge is pushed into the aligning profile of the clamp by hand until the movable claw engages with the connection grooves of the edge profile enough to hold the clamp safely in position.

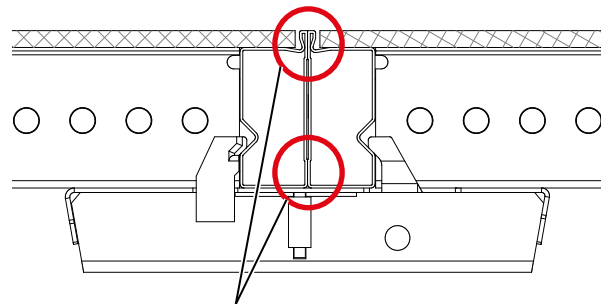
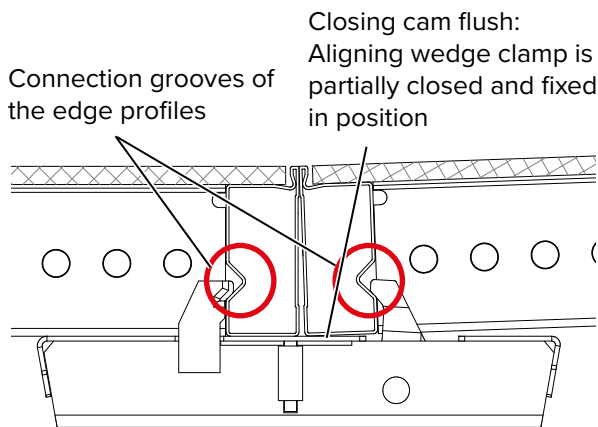

The contact surfaces of the sides of the panels project slightly out of the edge profile allowing easy removal of concrete residue and preventing that small remaining concrete residue can hinder the panel alignment.



VISUAL CHECK

Check the correct seating of the dual claws within the grooves of the edge profiles to prevent the clamp from falling down.

4. Hammer the wedge into the clamp until the panel joint is fully closed and aligned.

7.3 Elevation steps between panels

7.3.1 Steps up to 2.0 cm

The PLATINUM aligning wedge clamps are typically placed on top of the panel ribs. The double claws of the clamps allow an elevation step between two panels of up to 2.0 cm.

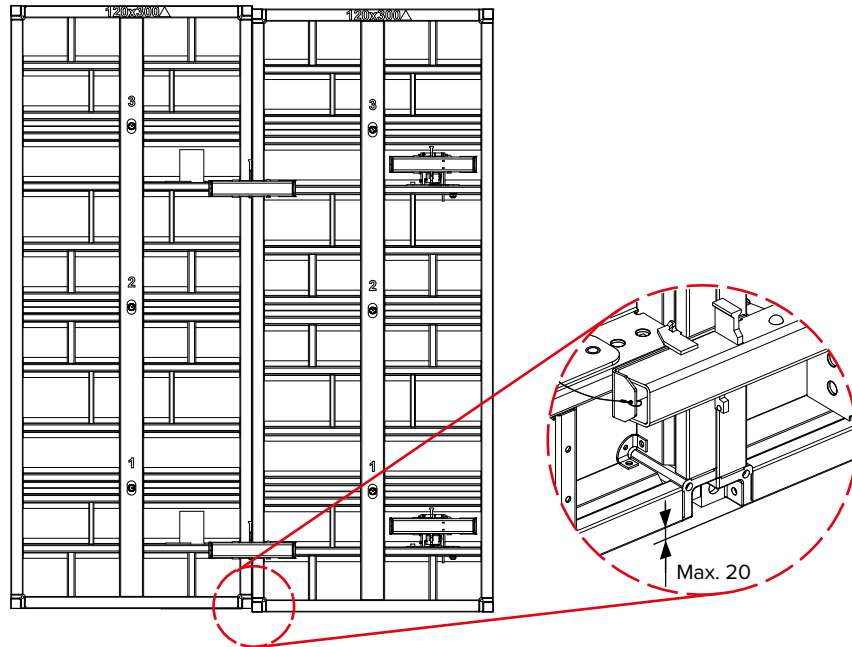

7.3.2 Steps bigger than 2.0 cm

With bigger elevation steps the aligning wedge clamps can be arranged freely along the edge profiles of the panels. In this case the aligning wedge clamps only close the panel joints tightly and tensile. The aligning function and the stiffness against bending must be supported by arranging additional walers.

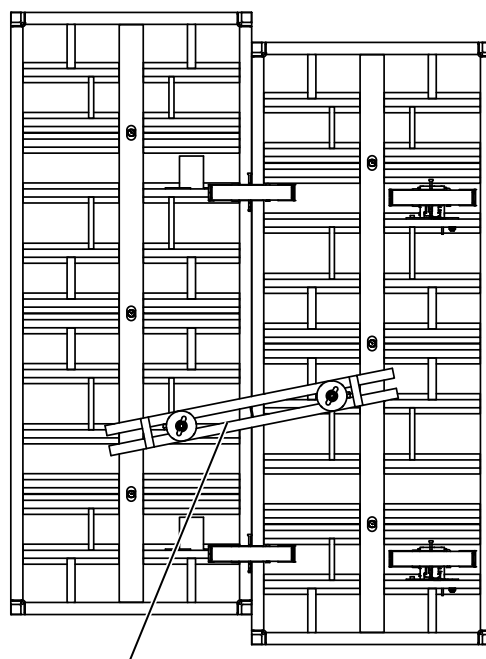

Waler 146 (prod. code 503893) with multi bolt and MANTO tie nut

7.4 Vertical connection and stacking

The stacking variations on the following pages show examples of the minimum number and correct position of connection parts required for lifting panel assemblies with the crane out of the horizontal position as well as the minimum number and correct positions of the ties. The stacking variations shown here cover the lifting of panel assemblies from the horizontal position with form face down and up.

Stacking with aligning wedge clamp

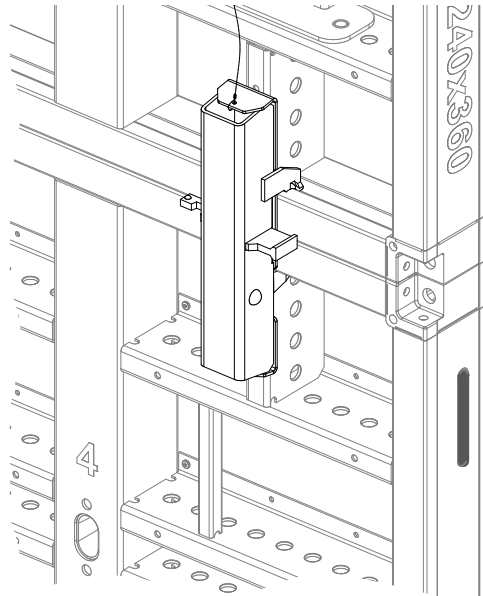

Advantage:

Simplified crane handling without additional connection hardware, independent of the position of the form face.

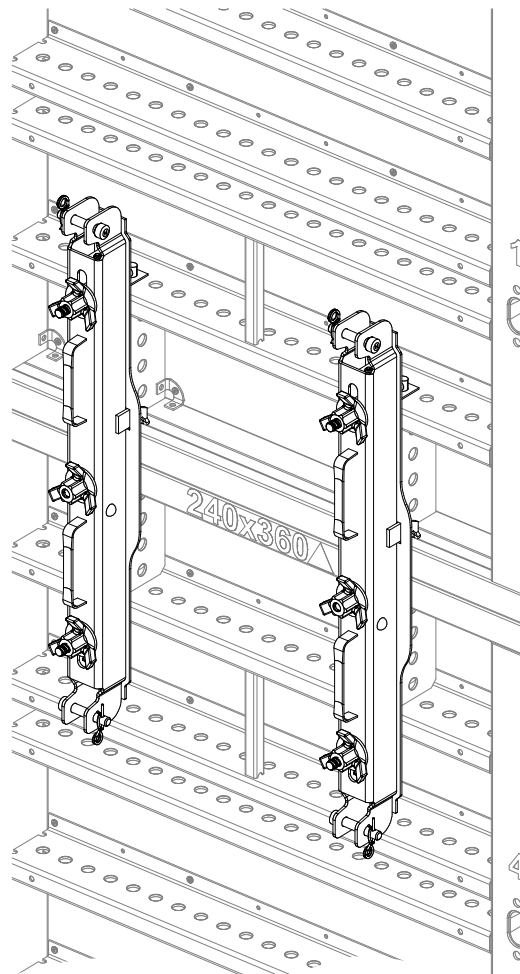
Stacking with PLATINUM 100 MANTO extension bar**WARNING****Warning!**

The aligning wedge clamp must always be placed over the panel ribs!

**WARNING****Warning!**

The top row ties or dry ties have to be used when walkways or platforms are attached at the top of the panels!

7.5 PLATINUM 100 MANTO extension bar

Panel extensions are mounted safely to lying formwork.



VISUAL CHECK

To prevent the clamp from falling down make sure that the dual claws sit correctly within the grooves of the edge profiles.

Position the extension bar over the connection point. To close the claw press the extension bar towards the panel until the claws encompass the panel joint completely.

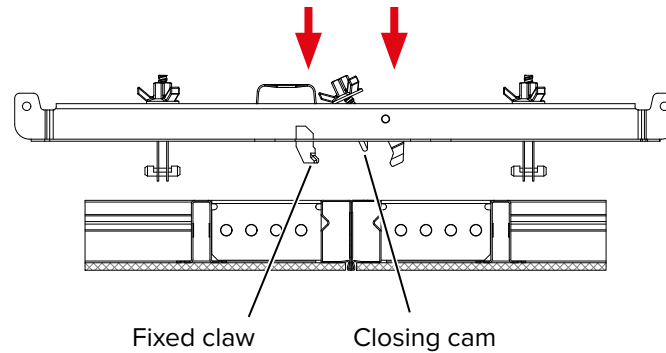

Now close the claw by tightening the middle wing nut with a hammer.

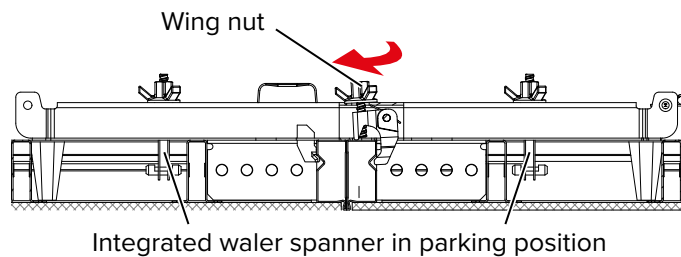

The integrated water spanners are taken out of their parking position.

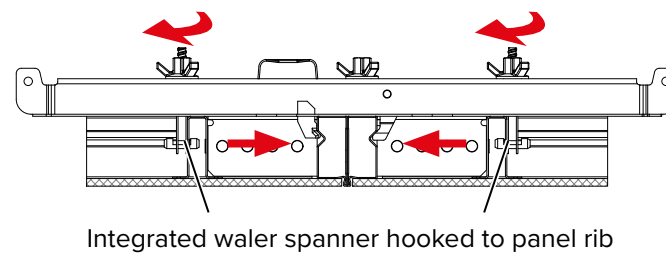

Push the integrated water spanners towards the panel ribs and hook them to the holes in the profile. Fix the water spanners by strongly tightening the wing nuts.



If panels must be added to vertical standing panels, or an existing standing formwork must be changed, then hook in the extension bar with the fixed double claw at top, first.

7.5.1 Examples for economically optimized extensions with 300 cm basic height

The examples show the minimum number of form ties achieving a non-symmetrical tie arrangement for optimized material quantities and labor costs. By using all tie locations a symmetrical tie pattern with deflections according to DIN 18202, table 3, line 7 can be achieved.

- Legend:
-  Bulkhead clamp with spacer by site
 -  Tie
 -  Aligning wedge clamp

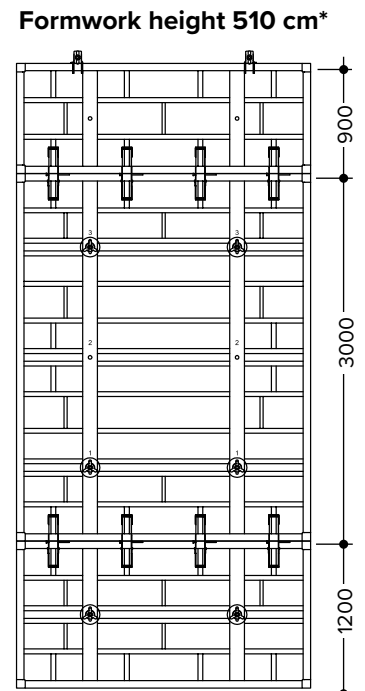
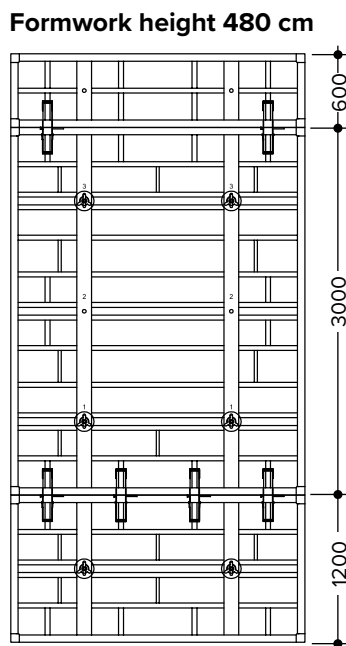
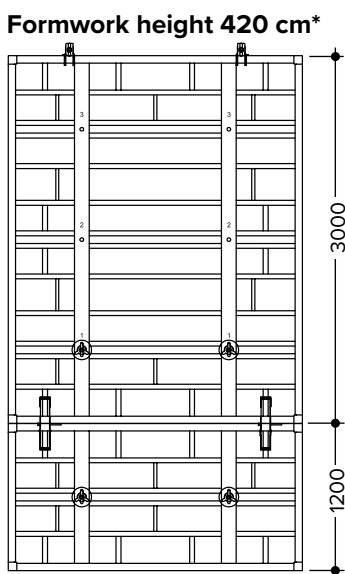
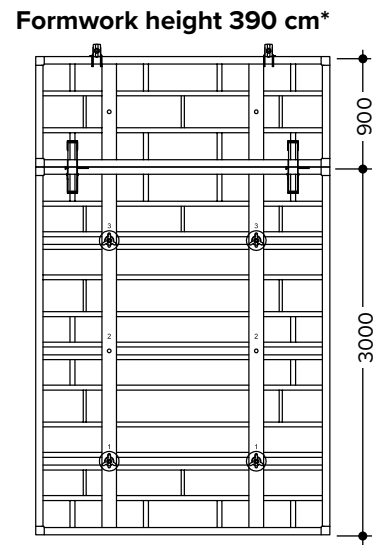
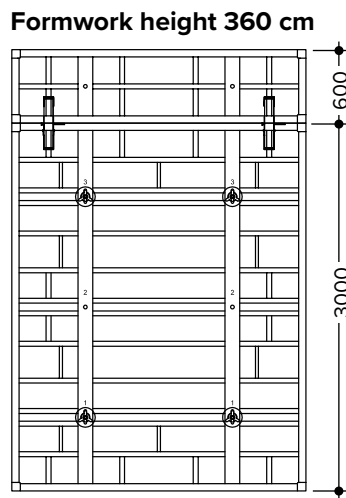
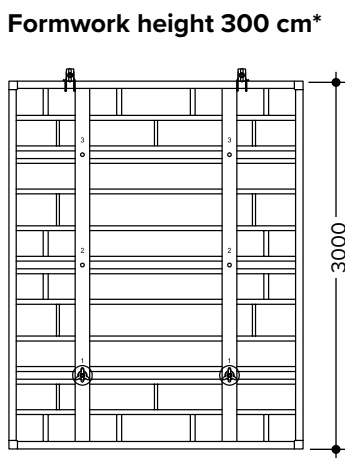
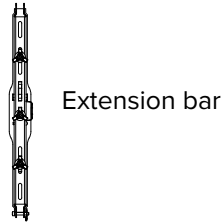

* DIN 18202, table 3, row 6

Formwork height 540 cm*

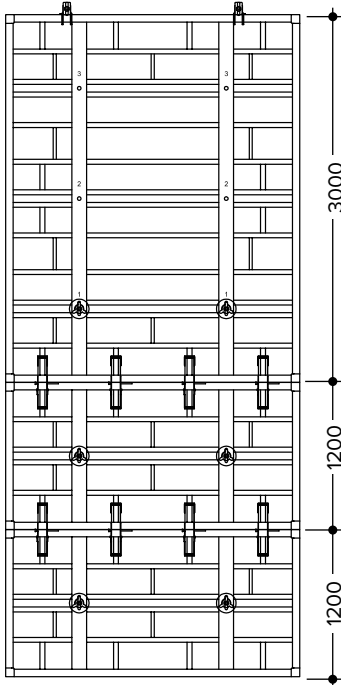

Formwork height 600 cm*

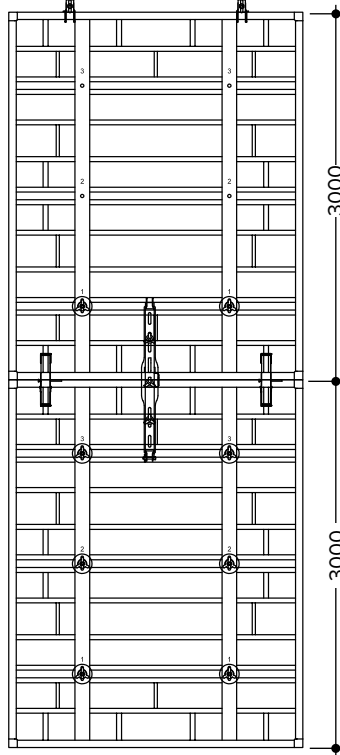

Formwork height 660 cm

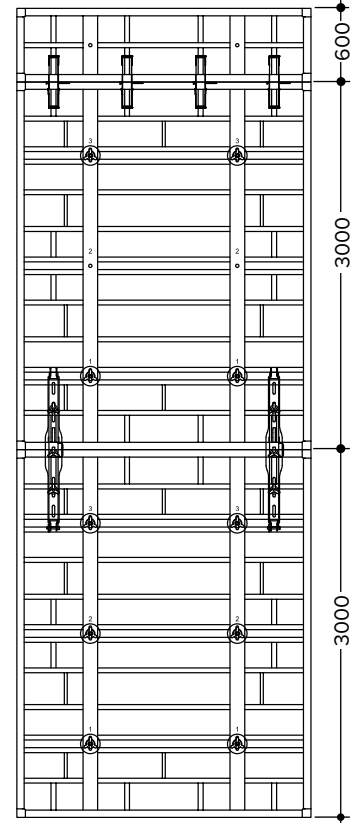

Formwork height 690 cm*

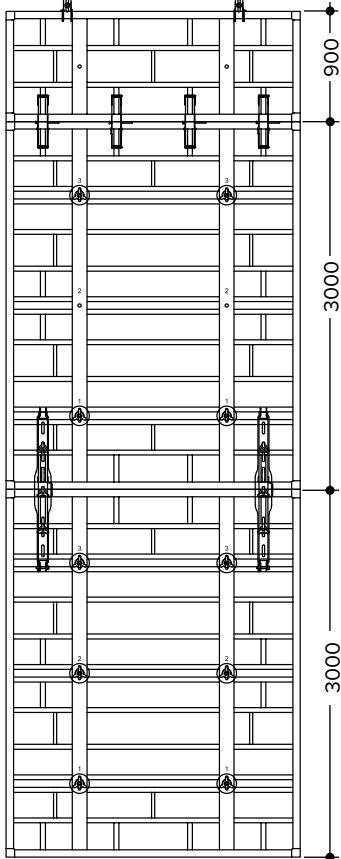

Formwork height 720 cm*

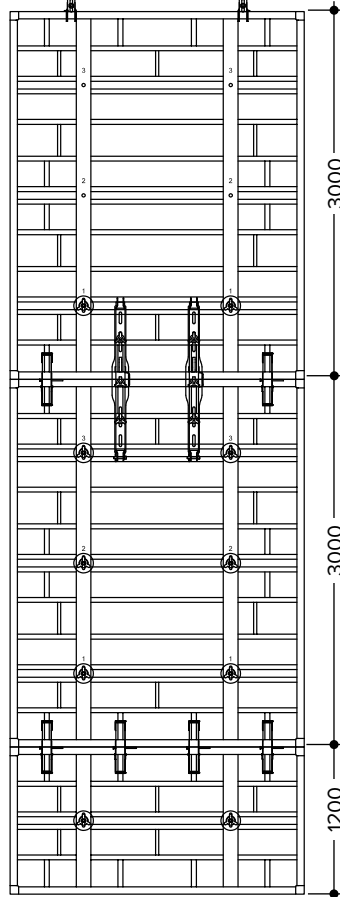

Formwork height 780 cm

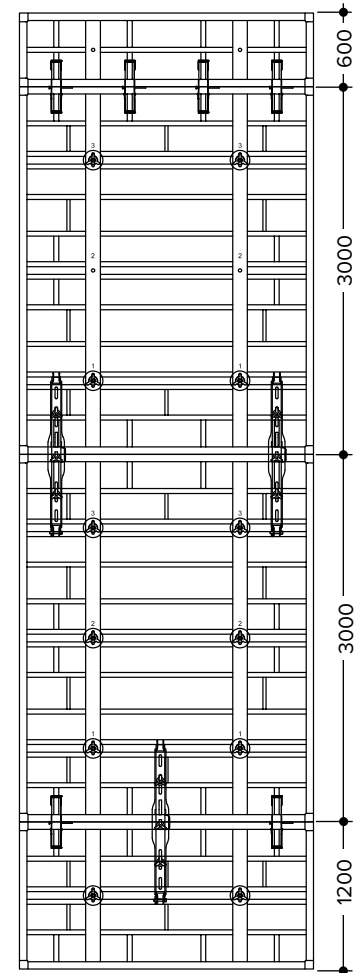

* DIN 18202, table 3, row 6

Formwork height 810 cm*

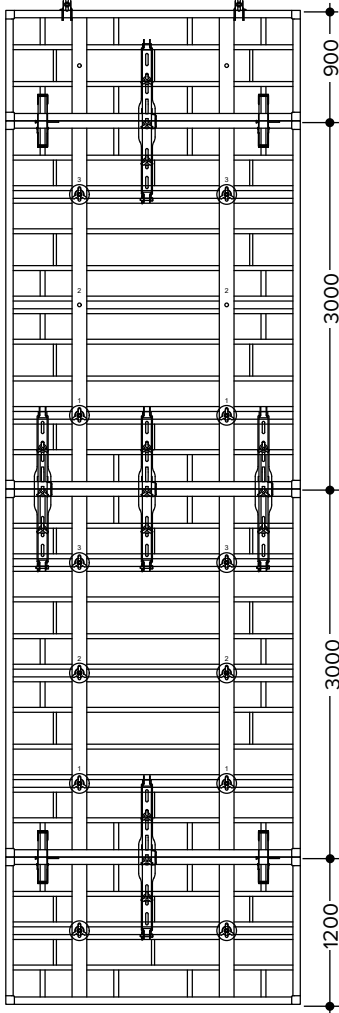

Formwork height 840 cm*

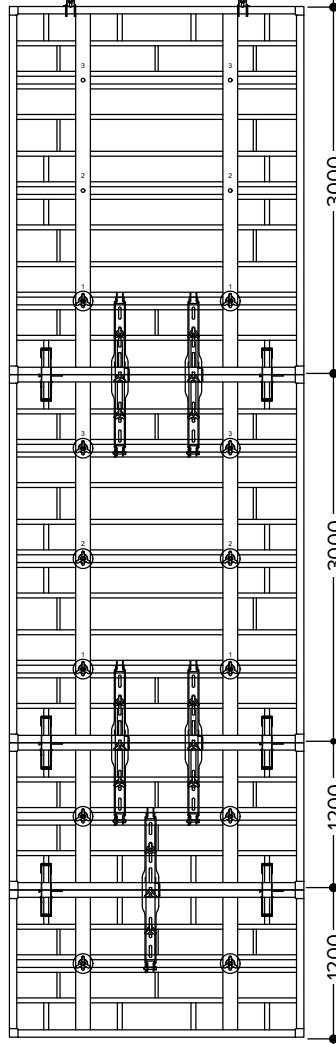

Formwork height 900 cm*

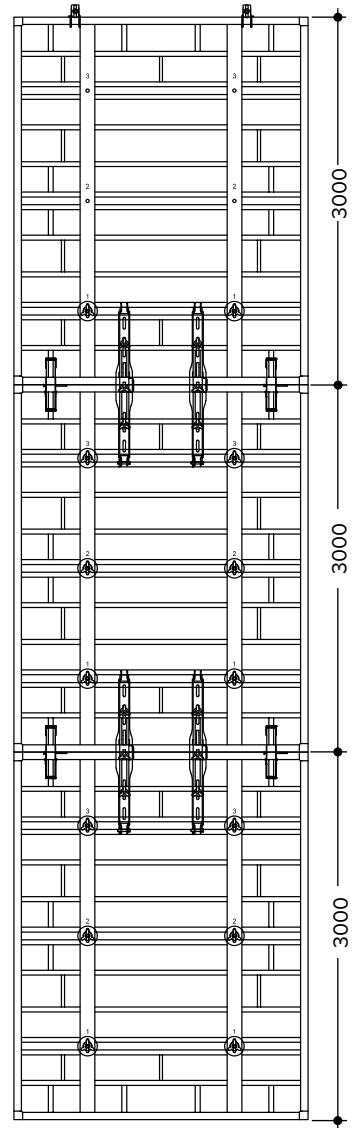

* DIN 18202, table 3, row 6

7.5.2 Examples for stackings with 360 cm basic height

The examples show the minimum number of form ties achieving a non-symmetrical tie arrangement for optimized material quantities and labor costs. By using all tie locations a symmetrical tie pattern with deflections according to DIN 18202, table 3, line 7 can be achieved.

Legend:

 Bulkhead clamp with spacer by site

 Tie

 Aligning wedge clamp

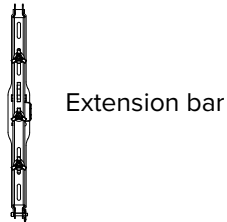

Formwork height 360 cm

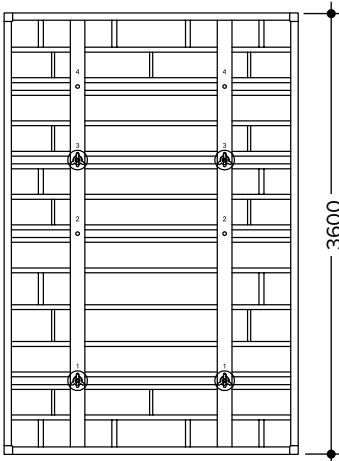

Formwork height 420 cm*

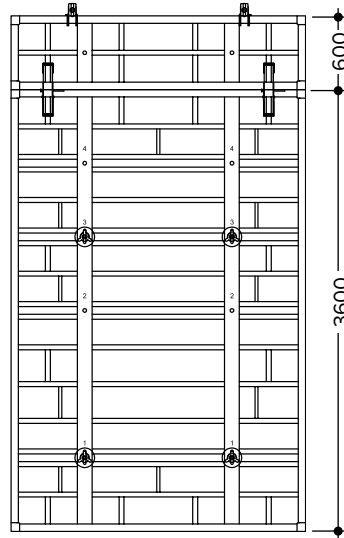

Formwork height 450 cm*

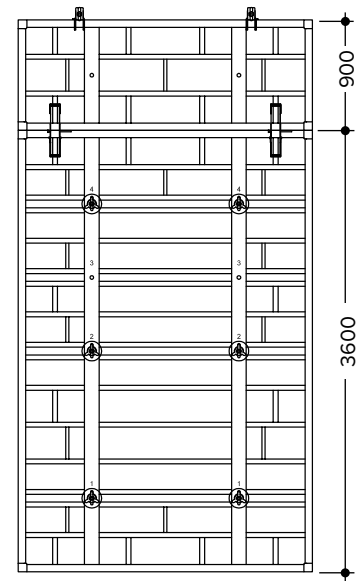

Formwork height 480 cm

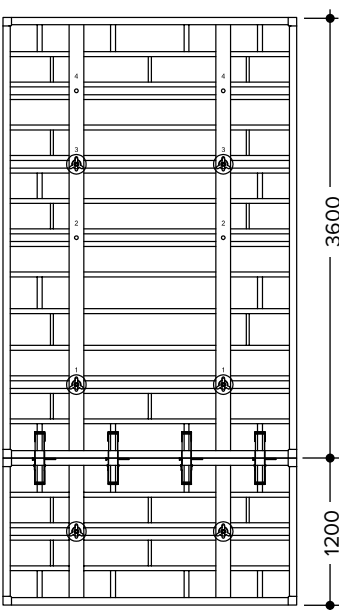

Formwork height 540 cm*

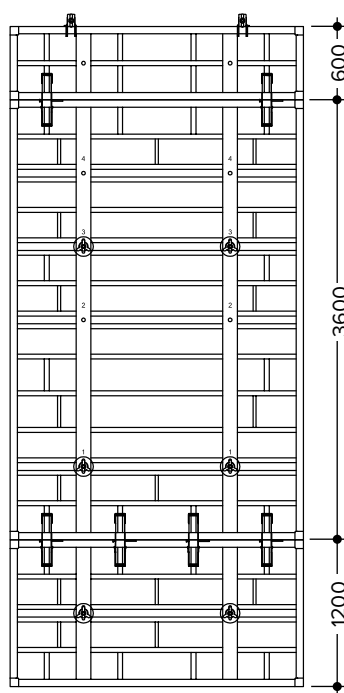

Formwork height 570 cm*

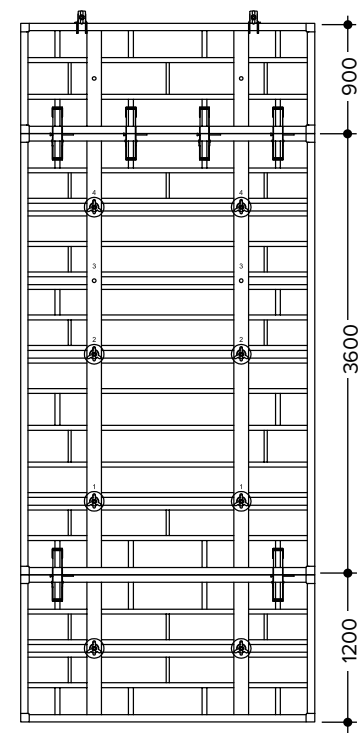

* DIN 18202, table 3, row 6

Alternative:

Formwork height 600 cm

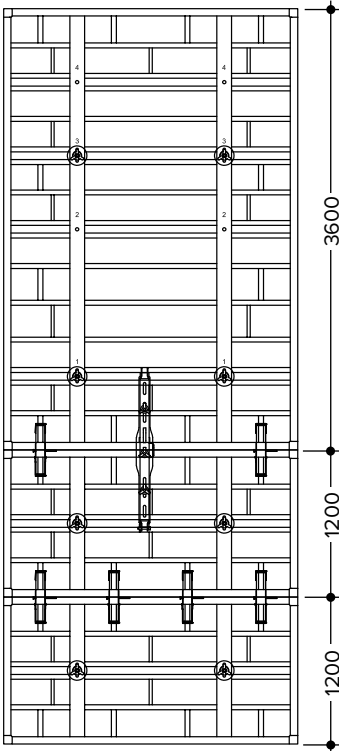

Formwork height 660 cm*

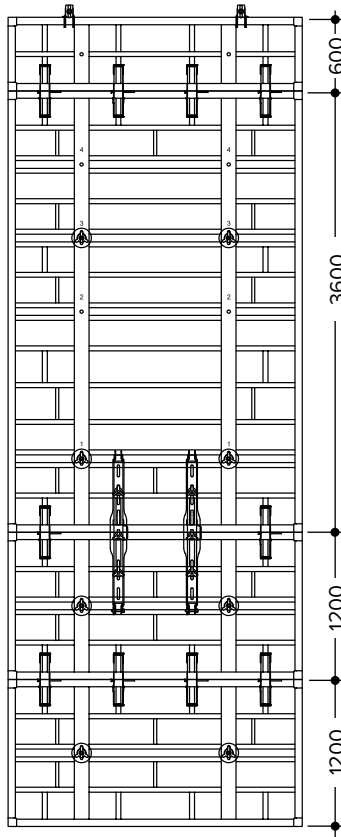

Formwork height 660 cm*

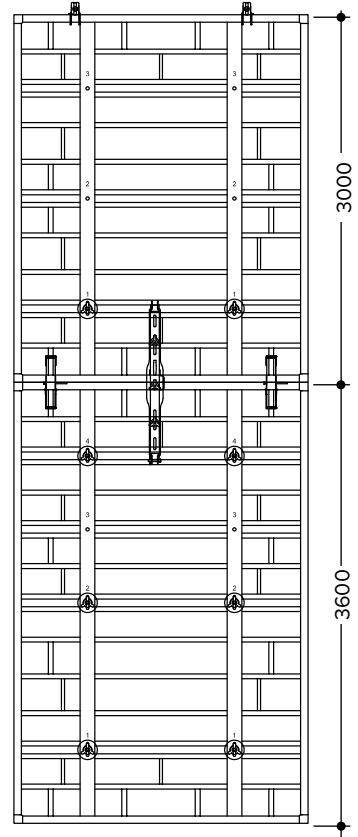

* DIN 18202, table 3, row 6

Formwork height 690 cm*

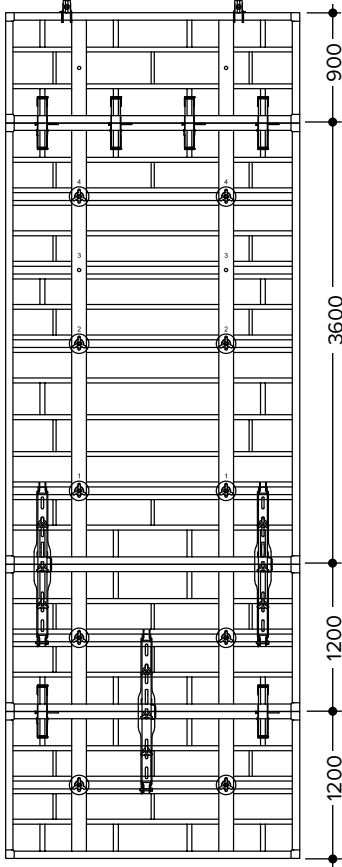

Formwork height 720 cm

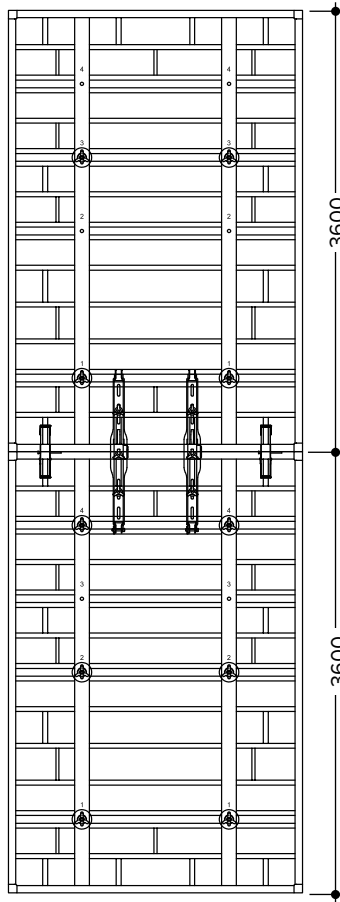

Formwork height 780 cm*

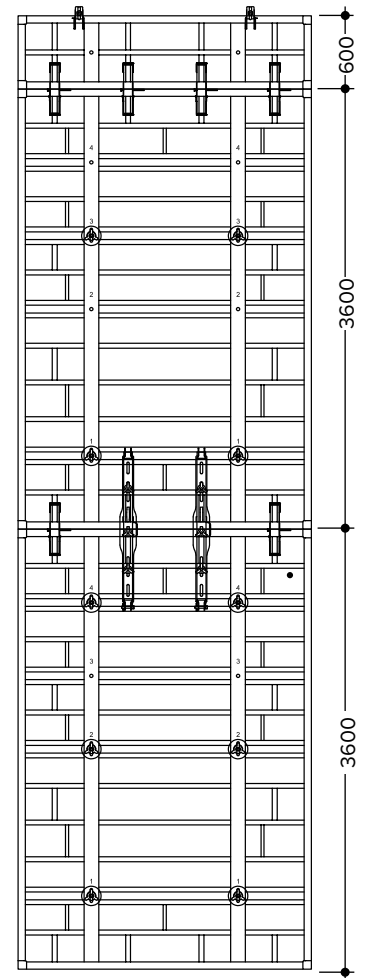

* DIN 18202, table 3, row 6

Formwork height 810 cm*

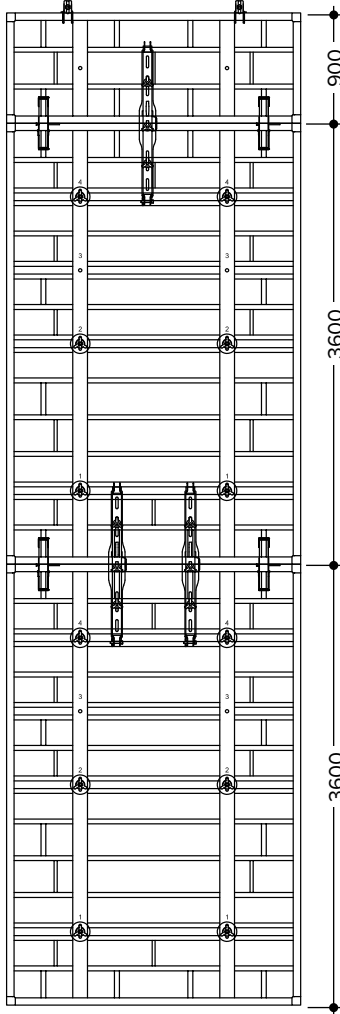

Formwork height 840 cm

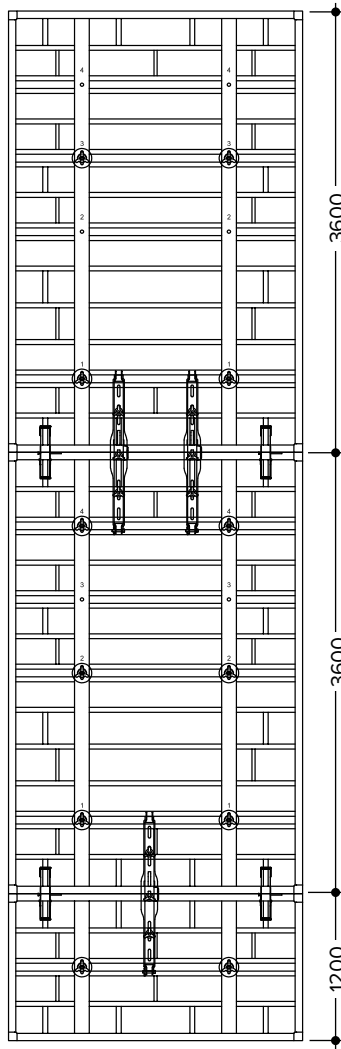

Formwork height 900 cm*

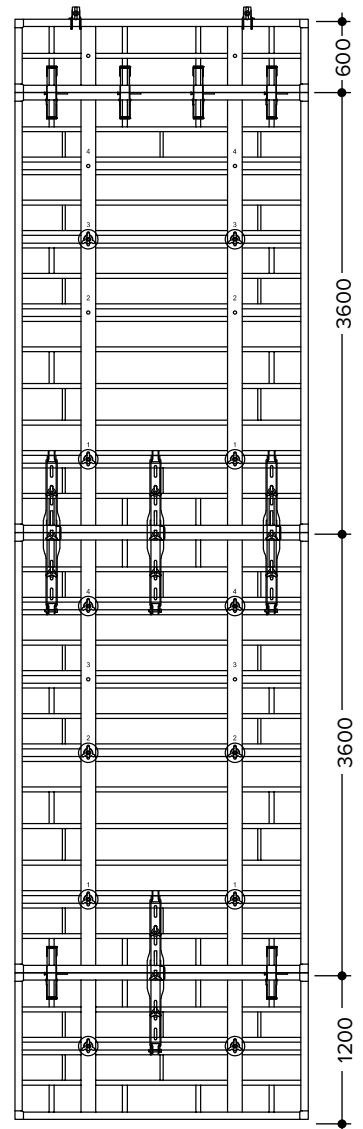

* DIN 18202, table 3, row 6

Formwork height 1.020 cm*

Formwork height 930 cm*

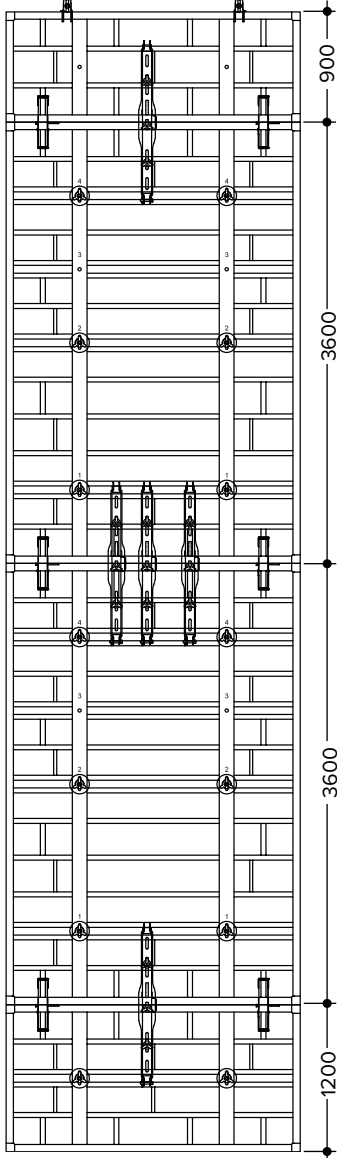

Formwork height 960 cm

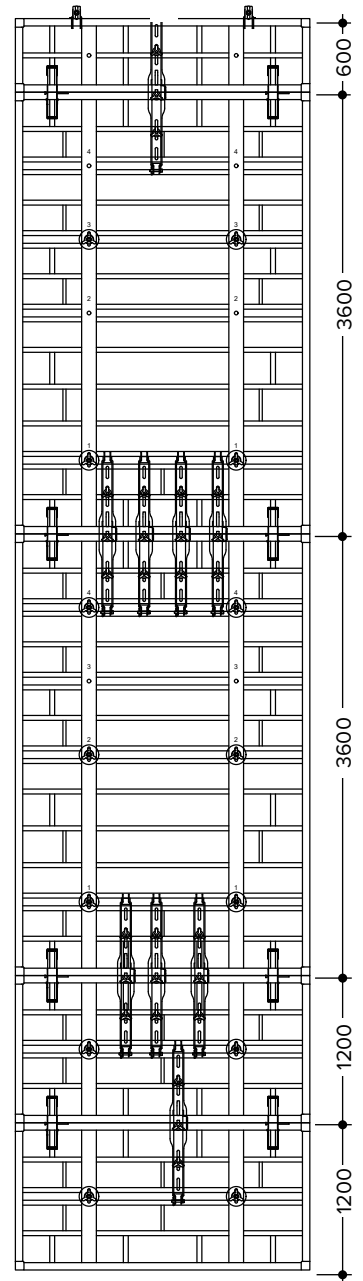
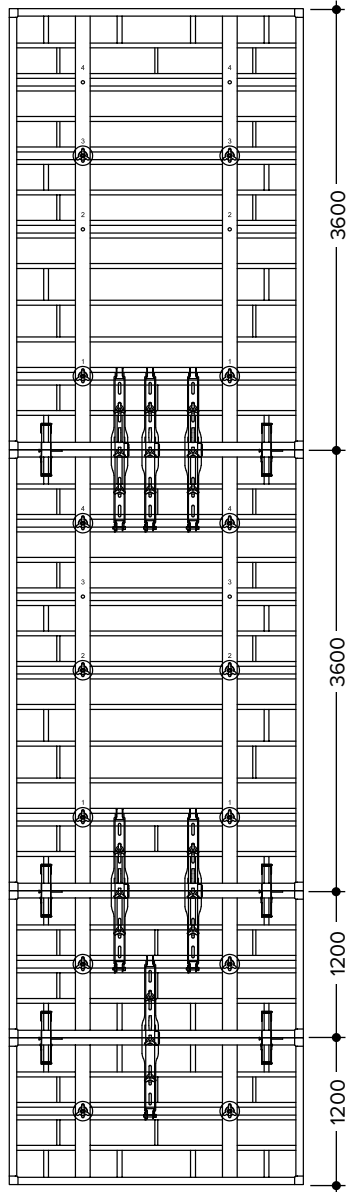

* DIN 18202, table 3, row 6

Formwork height 1.020 cm*

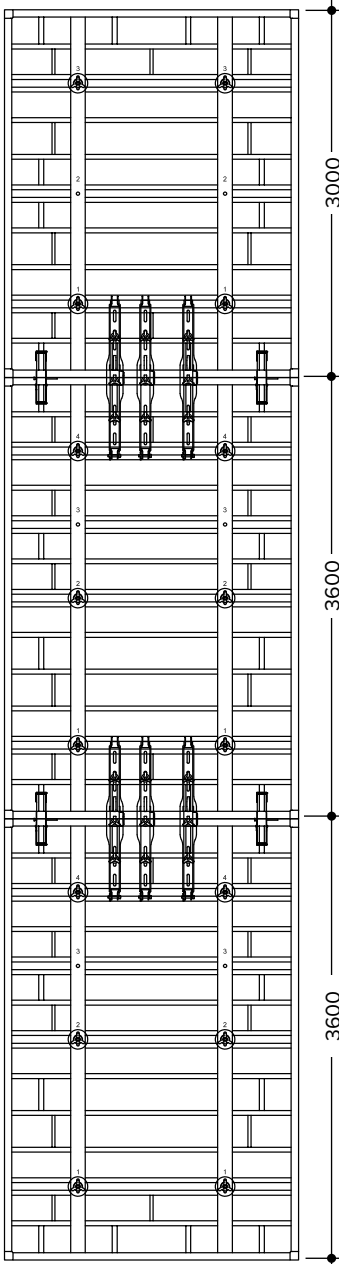

Formwork height 1.050 cm*

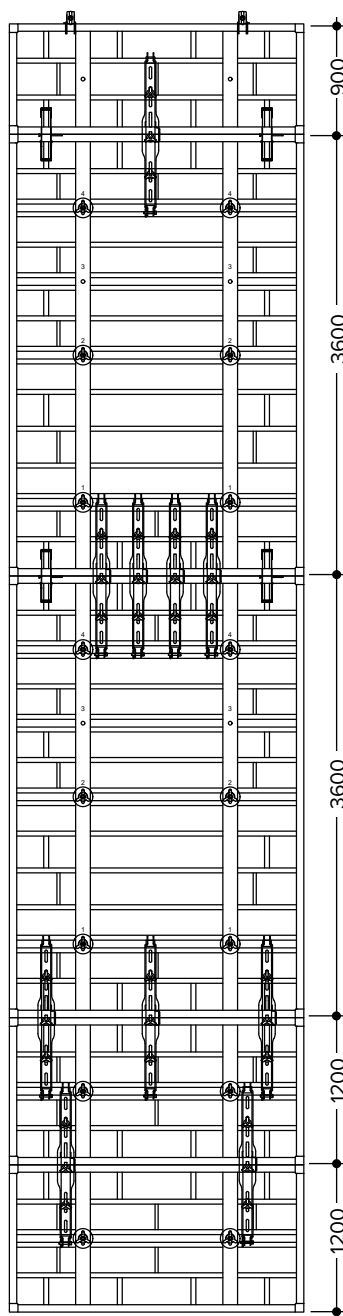

Formwork height 1.080 cm

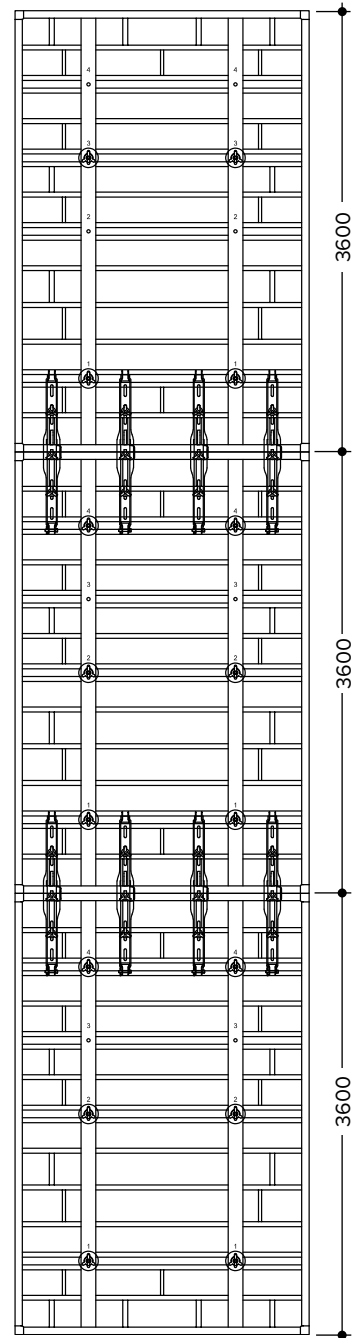

* DIN 18202, table 3, row 6

8 Tie technology

The PLATINUM 100 panel range offers variable and effective tie possibilities for every situation. Regardless of whether the PLATINUM 100 tie rod (see on page 55), the traditional DW 20 tie (see on page 63) with thru tubes and cones or water stop with double cone and lost inner unit is being used, the multifunctional tie holes of the PLATINUM 100 panels always offer solutions to any application.

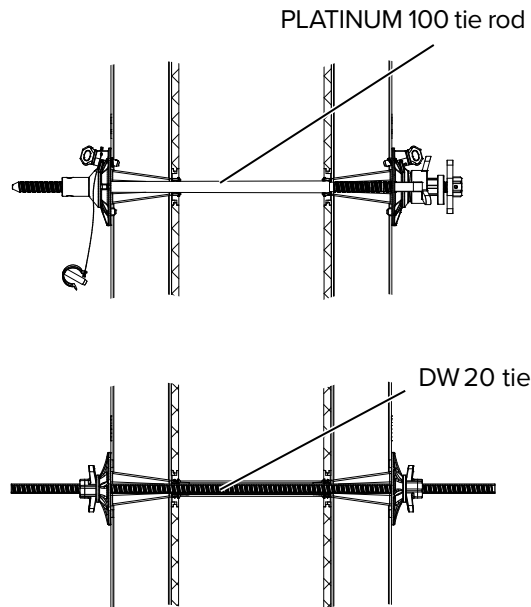

8.1 Tie holes of panels

All tie locations of the PLATINUM 100 panels are equipped with robust, hard plastic, multi-functional reinforcement rings that are embedded flush into the ECOPLY form sheets and typically equipped with the PLATINUM 100 closing plugs. The closed tie locations leave a uniform and barely visible imprint in the concrete surface - suitable for high-quality exposed concrete. When equipping the tie hole with a tie, the closing plug can easily be removed out of the multi-functional reinforcement ring and replaced by the desired cone solution.

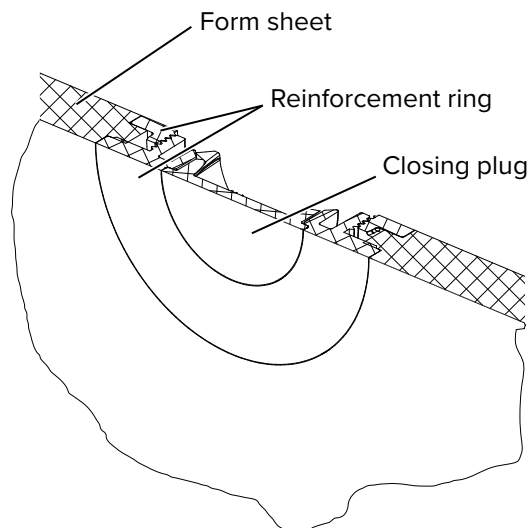

8.2 Preparing the tie hole

After the selection of the tie arrangement remove the closing plug (for selecting a suitable tie arrangement see page 29). The open tie hole has to be equipped with the correct insert cone, which depends on the selected tie system. The inserts achieve a clean optical result without the typical concrete break-out caused during removal of traditional tapered ties. The cones are equipped with a self-locking mechanism that secures the cone with a clockwise turn into the reinforced ring to prevent them from being lost.

The plugs can be used multiple times. The sealing plugs can be removed carefully with the PLATINUM 100 cone gripper. PLATINUM 100 dummy cones can be used to achieve architectural patterns at tie locations that are not used.

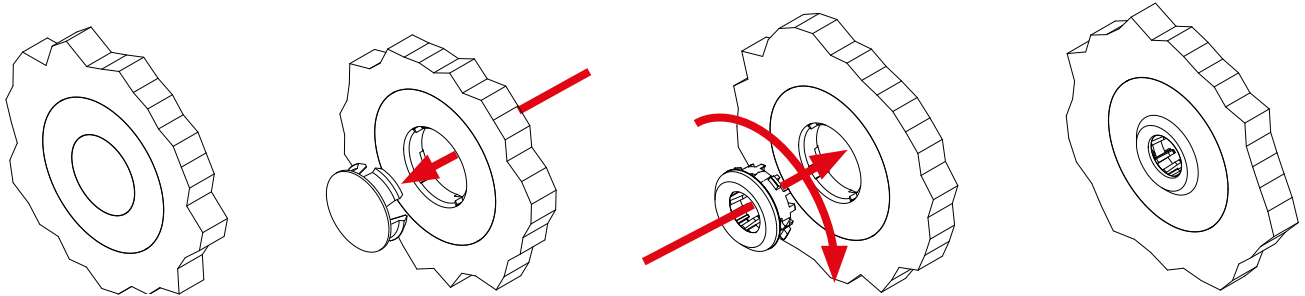

PLATINUM 100 closing plug; prod. code 604550, the standard plug for the tie holes

PLATINUM 100 sealing cone; prod. code 604555, for the insertion of the PLATINUM 100 tie rod

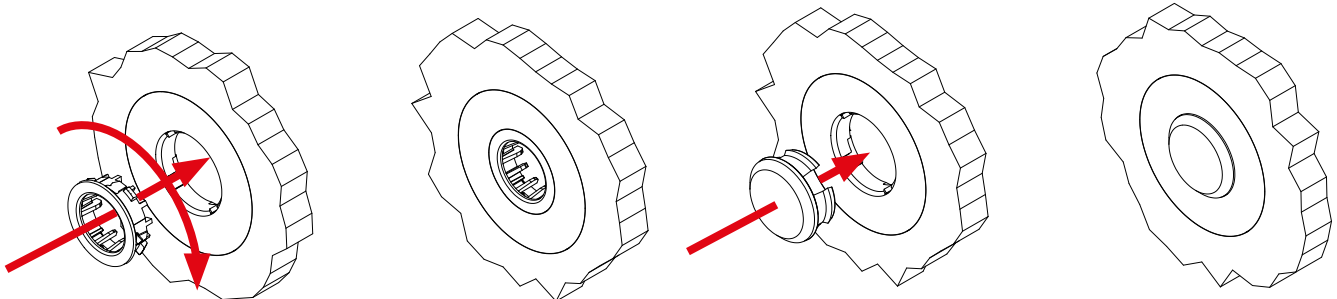

PLATINUM 100 universal flat ring; prod. code 604560, with PLATINUM 100 thru tube cone 26 mm; prod. code 604575, and thru tube for the insertion of traditional DW20 tie rods

PLATINUM 100 dummy cone; prod. code 604576, for the structural design of unused tie holes

NOTE

Note!

The dummy cone has the same geometry as the sealing cone producing an equal imprint in the concrete surface of used and unused tie locations.

8.3 Assembly of sealing cone and universal flat ring

NOTE

Note!

Check condition of plugs before assembly!

- Step 1** After removing the closing plug, insert the PLATINUM 100 sealing cone or the PLATINUM 100 universal flat ring with the hammer head into the reinforcement ring of the tie hole.
Make sure that the plug is flush to the reinforcement ring.
- Step 2** Next, insert the PLATINUM 100 cone gripper into the plug with care, not to damage the sealing of the cone or flat ring.
- Step 3** Spread the cone gripper and turn it 15° clockwise with the plug until the hammer head lock snaps in.
Now the plug is fixed.

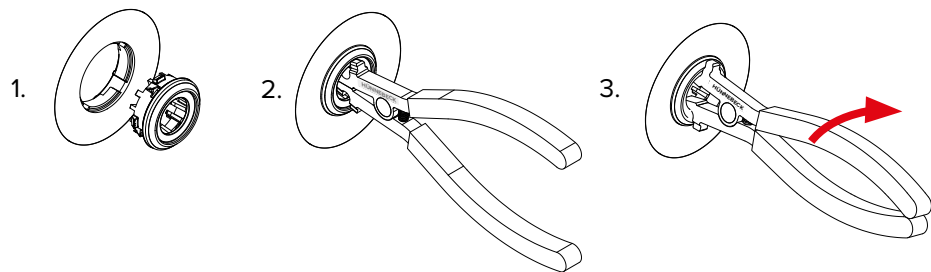

8.4 Removal of sealing ring and universal flat ring

To remove these plugs insert the cone gripper as described in step 2, press the handles and break the plugs out.

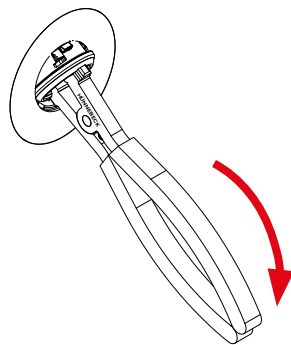

NOTE

Note!

Do not turn out the plugs!
Do not reuse removed plugs.

8.5 PLATINUM 100 tie rod

The PLATINUM 100 tie is the optimal tie system for simple, efficient and safe use of the PLATINUM 100 system and is capable of withstanding a constant fresh concrete pressure of 100 kN/m².

There are 2 versions of the PLATINUM 100 tie rod available, Generation 1 (G1) and Generation 2 (G2). The tie rod G2 has been modified and the adjusting washer for adjusting the wall thickness has been replaced by the hinged adjustment clip. This facilitates the adjustment of the wall thickness.

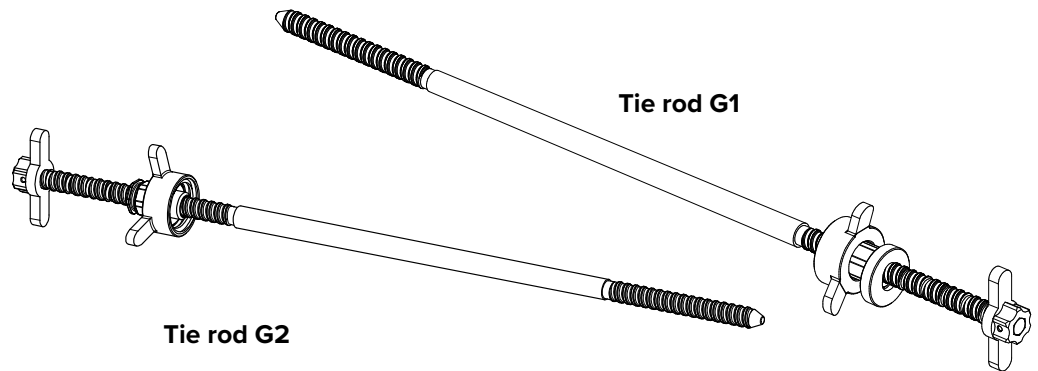

PLATINUM 100 tie system

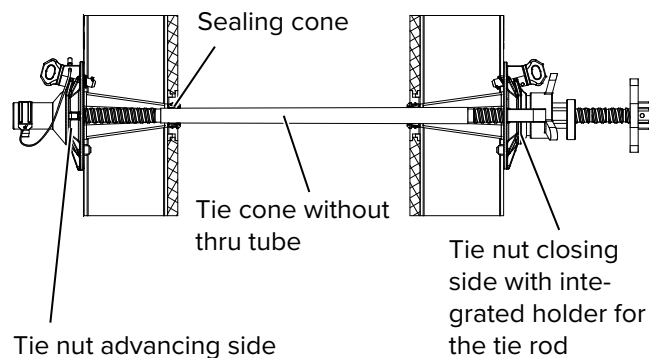

The PLATINUM 100 tie system is highly-efficient:

- It is operated from one side only.
- It is resistant to pressure and tension
- It is pre-adjustable to any wall thicknesses from 15 to 42.5 cm (tie rod G1) or 14 to 40 cm (tie rod G2).
- It allows direct pre-adjustment of common wall thicknesses in 2.5 cm (tie rod G1) or 1 to 1,5 cm (tie rod G2) increments without measuring.
- It is equipped with robust long-lasting corrosion protection to withstand wear and tear on site.
- It is used without thru tubes and spreaders.
- It has a safe working load of 150 kN (according to DIN 18216).
- It reliably supports 2.16 m² of forming area under hydrostatic fresh concrete pressure.

The PLATINUM 100 tie nut closing side is equipped with a unique tie rod holder for the PLATINUM 100 tie rods. This allows the tie rods to be safely stowed by the panels during transport. As a result, the number of loose parts on site and during material transport can be reduced, and assembly time can be saved.

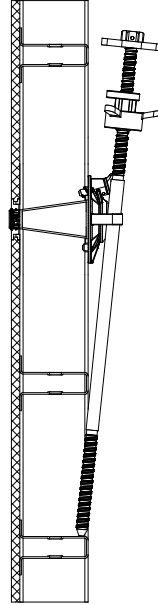

Tie nut closing side with PLATINUM 100 tie rod in holder

8.5.1 Preparing the advancing side

The PLATINUM 100 tie nut advancing side is hooked into the relevant tie point on the back of the formwork panel and screwed tightly to the panel frame with the fixing screw. Depending on the required wall thickness, it may be necessary to remove the pin clip from the tie nut on the advancing side.

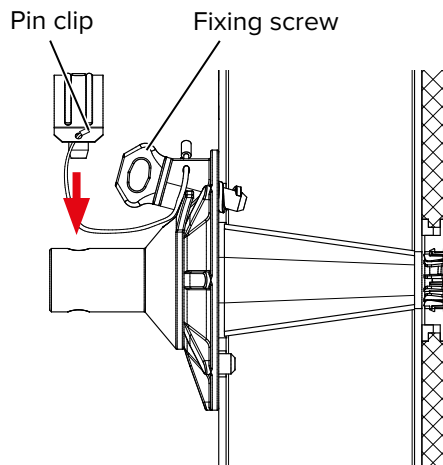

Fixing of the PLATINUM 100 tie nut advancing side

8.5.2 Preparing the closing side

The PLATINUM 100 tie nut closing side is hooked into the relevant tie point on the back of the formwork panel and screwed tightly with the fixing screw to the panel frame.

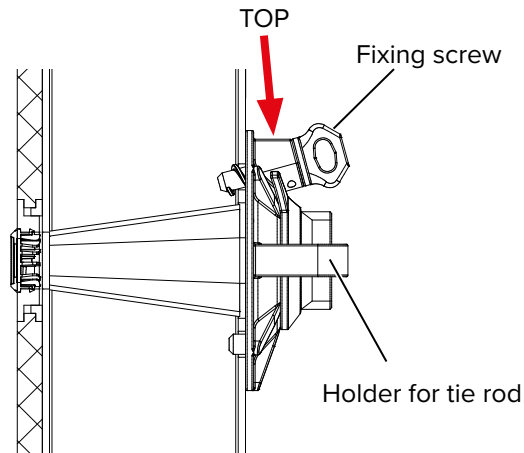

Fixing of the PLATINUM 100 tie nut closing side

8.5.3 Preparing the PLATINUM 100 tie rod

Preparing the tie rod differs depending on the generation of the tie rod. Following, the preparation of the tie rod G1 is described. After that the preparation of the tie rod G2 is described.

Preparing the tie rod G1

The PLATINUM 100 tie rod is delivered to the construction site as an assembly with counter nut, adjusting nut and adjustment washer.

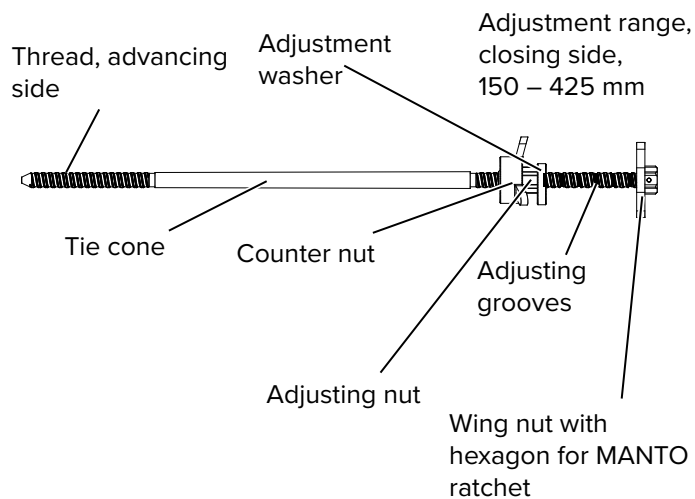

The PLATINUM 100 tie rod allows the required wall thickness to be set before installation. Common wall thicknesses can be selected by placing the adjustment washer in the appropriate groove without having to measure. Other wall thicknesses can be freely set, without using the predefined settings.

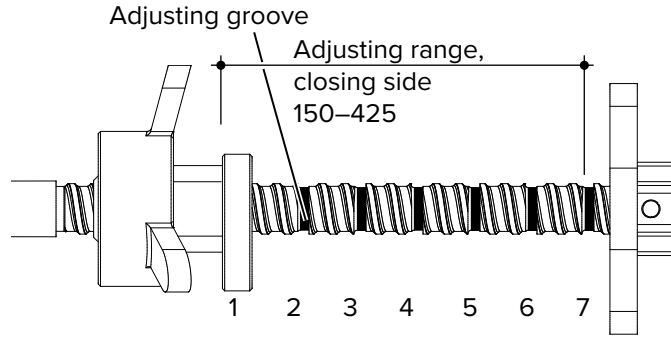

The predefined wall thicknesses can be set from 15 to 42.5 cm, in increments of 2.5 cm.

Decisive for the correct set-up of the PLATINUM 100 tie rod is to know if the tie nut at the advancing formwork side is equipped with a pin clip or not.

In the following step the PLATINUM 100 tie rod is screwed into the tie nut advancing side until it reaches the pin clip.

If the pin clip has been removed, the PLATINUM 100 tie rod has to be screwed completely into the tie nut on the advancing side.

With pin clip inserted

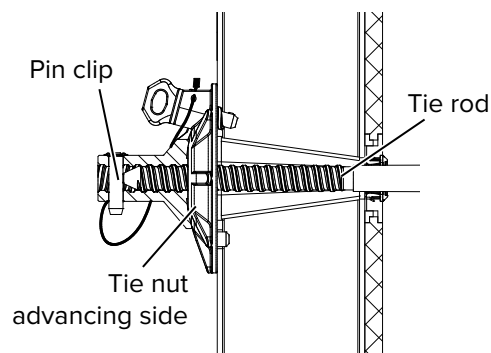

Without pin clip inserted

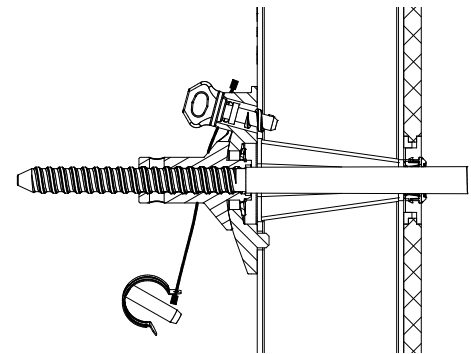

Depending on this, the following wall thicknesses can be preset without measuring:

PLATINUM 100 tie nut advancing side	Adjusting positions PLATINUM 100 tie rod/wall thickness [cm]						
	1	2	3	4	5	6	7
Without pin clip	15	17.5	20	22.5	25	27.5	30
With pin clip	27.5	30	32.5	35	37.5	40	42.5

Step 1 To set the desired wall thickness, position the adjustment washer in the appropriate adjusting groove.

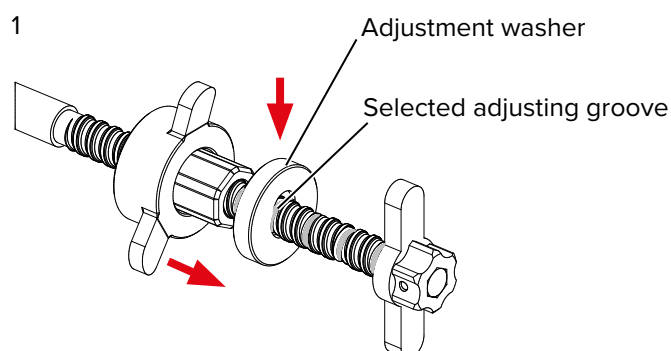

Step 2 Screw the adjustment nut on the tie into the adjustment washer to secure the pre-selected position.

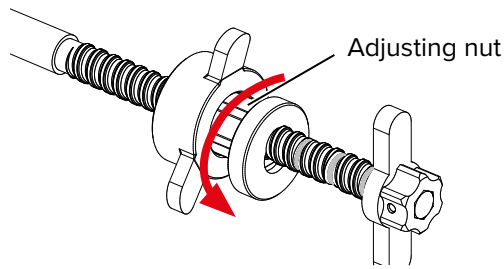

Preparing the tie rod G2

The PLATINUM 100 tie rod is delivered to the construction site as an assembly with counter nut and adjustment washer.

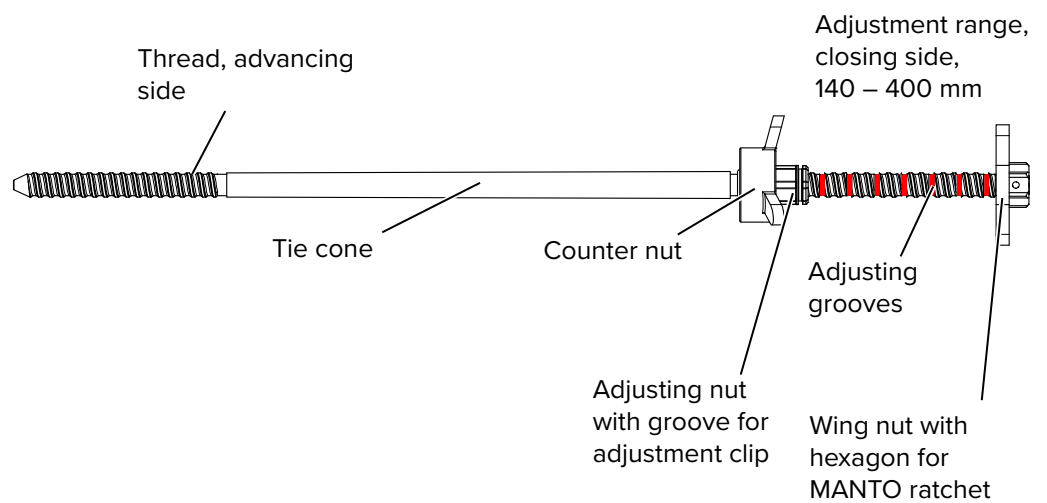

The PLATINUM 100 tie rod allows the required wall thickness to be set before installation. Common wall thicknesses can be selected by placing the adjustment clip in the appropriate groove without having to measure. The adjustment grooves 1-6 can be used (see figure below). Other wall thicknesses can be freely set, without using the predefined settings.

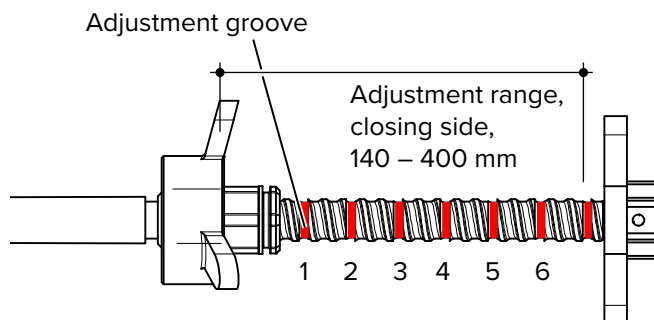

The predefined wall thicknesses can be set from 14 to 40 cm, in increments of 1 to 1.5 cm. The adjustment clip can be placed on the adjusting nut in two positions, position 0 and position -1. Depending on the position different wall thicknesses can be set.

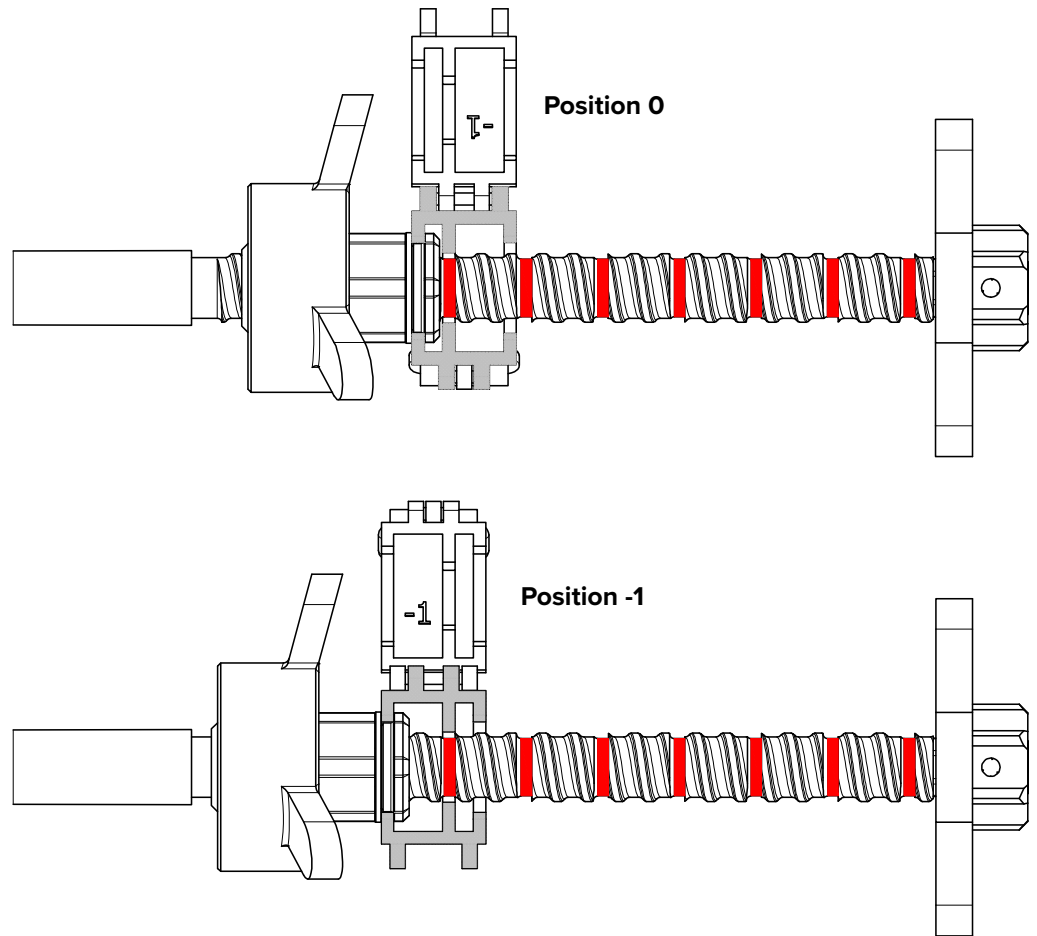

Decisive for the correct set-up of the PLATINUM 100 tie rod is to know if the tie nut at the advancing formwork side is equipped with a pin clip or not.

If the pin clip is installed, the tie rod stops at the pin clip when screwd into the tie nut.

If the pin clip has been removed, the PLATINUM 100 tie rod has to be screwd completely into the tie nut on the advancing side.

With pin clip

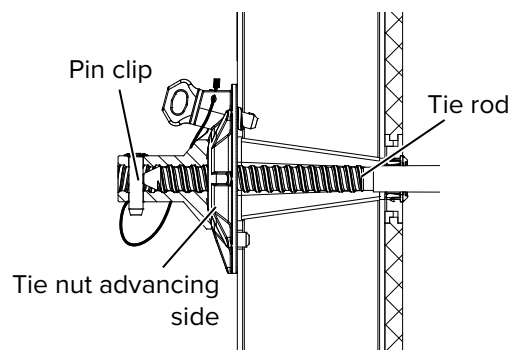

Without pin clip

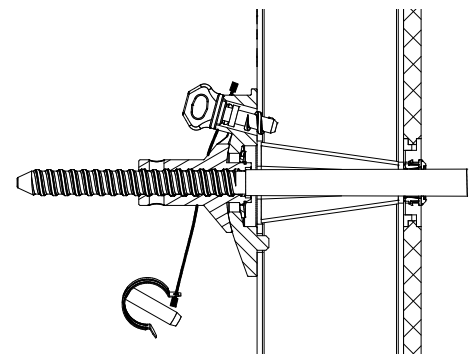

The following tables help you to find the correct parameters for your required wall thickness.

Wall thickness [cm]	14.0	15.0	16.5	17.5	19.0	20.0	21.5	22.5	24.0	25.0	26.5		
Pin clip in tie nut advancing side	∅	∅	∅	∅	∅	∅	∅	∅	∅	∅	∅	∅	
Position of the adjustment clip	-1	0	-1	0	-1	0	-1	0	-1	0	-1	-1	
Adjusting groove of tie rod	1	1	2	2	3	3	4	4	5	5	6	1	

Wall thickness [cm]	27.5	29.0	30.0	31.5	32.5	34.0	35.0	36.5	37.5	39.0	40.0		
Pin clip in tie nut advancing side	∅	∅	∅	∅	∅	∅	∅	∅	∅	∅	∅	∅	
Position of the adjustment clip	0	0	-1	0	-1	0	-1	0	-1	0	-1	0	
Adjusting groove of tie rod	6	1	2	2	3	3	4	4	5	5	6	6	

Step 1 Place the adjustment clip around the tie rod at the required position.

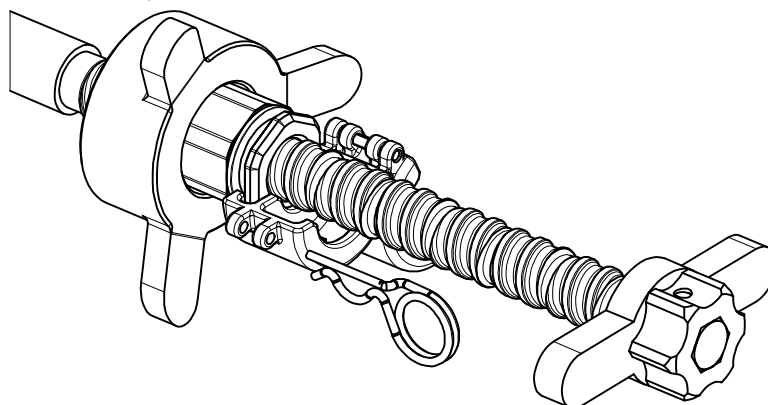

Step 2 Close and lock the adjustment clip.

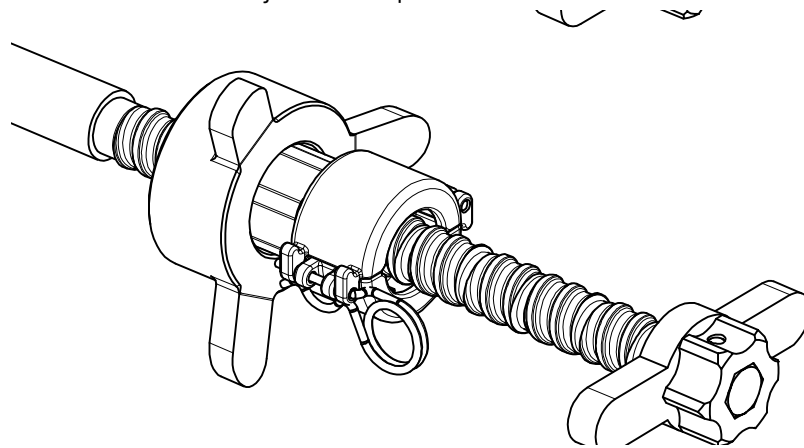

8.5.4 Assembly and connection

After presetting of the desired wall thickness, the PLATINUM 100 tie rod can be inserted into the prepared tie location of the closing and advancing side of the formwork.

NOTE

Note!

It is advisable to apply a thin film of release agent onto the conical areas of the tie rod that come in contact with concrete. This facilitates removal of the tie rod.

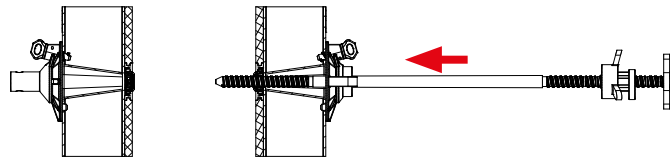

The PLATINUM 100 tie rod must be fully screwed into the nut on the advancing side until full stop and its end position. Then screw the counter nut onto the PLATINUM 100 closing nut. The PLATINUM 100 tie rod is now completely secured with the correct wall thickness and it is resistant to both tensile and compressive loads.

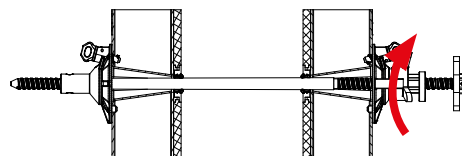
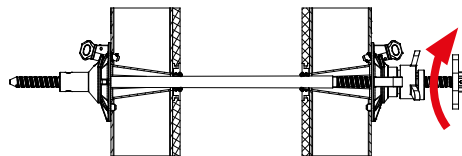

8.5.5 Removing the PLATINUM 100 tie rod

Removing the PLATINUM 100 tie rods is similar for both generations. Using the MANTO ratchet facilitates removal of the tie rods.

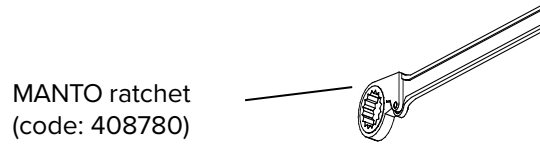

Step 1 Loosen the counter nut on the tie rod and remove it completely from the tie nut.

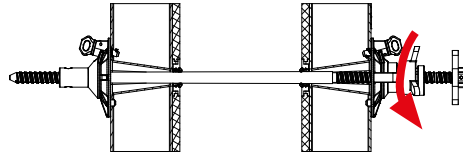

Step 2 Loosen the tie rod and remove it completely out of the formwork.

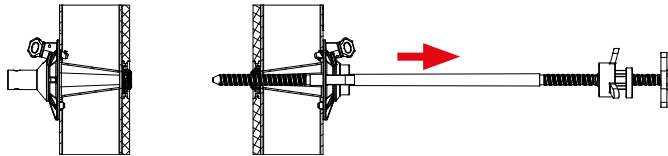

8.6 Traditional DW 20 ties

It is also possible to use the traditional DW 20 tie system with thru tubes, PLATINUM 100 universal flat ring and PLATINUM 100 thru tube cone with the PLATINUM 100 formwork.

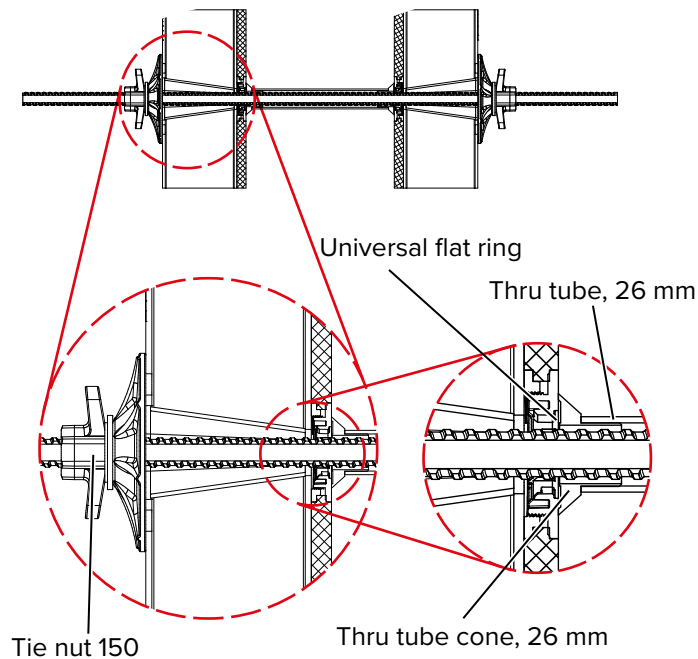

Warning!

Do not weld or heat tie rods as this may cause sudden failure!

8.7 Tie rod inclines and elevation changes

The PLATINUM 100 tie system allows angles of $\pm 2.5^\circ$ out of the perpendicular position in vertical directions. This makes it possible to tie inclined formwork or to accommodate different elevations between the opposing formwork.

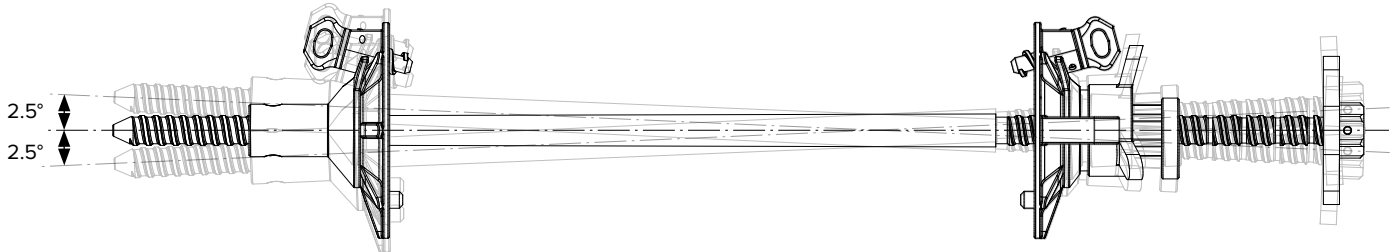

8.7.1 Inclined walls and elevation changes

When using the DW 20 tie system, standing PLATINUM 100 panels can be inclined with an angle of up to 7° out of the vertical due to the large, conically shaped tie holes.

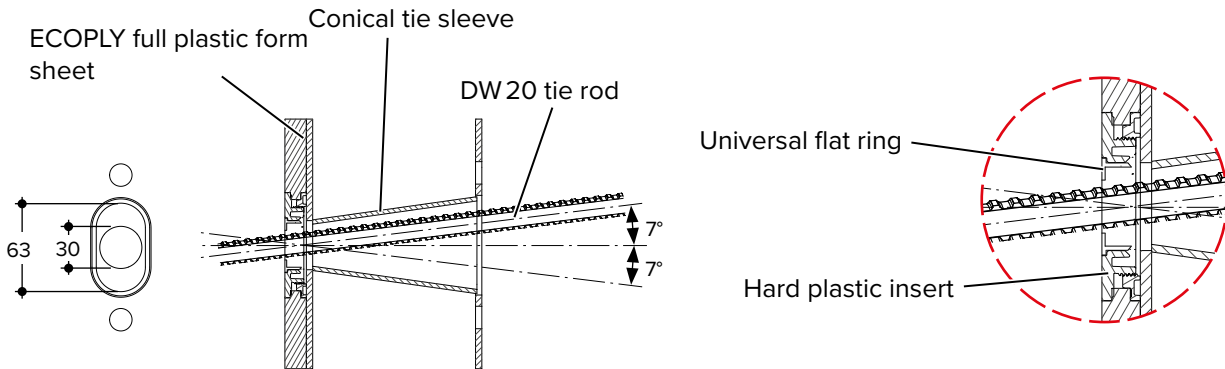

Possible forming settings:



WARNING

Warning!

Inclined panels and panels at different heights must be secured to prevent them from lifting up!

Formwork inclined on one side
 PLATINUM 100 tie rod = 2.5°
 DW 20 tie rod = 7°

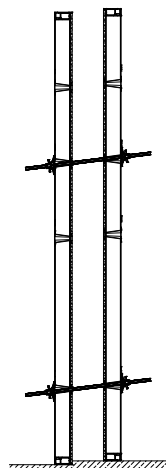
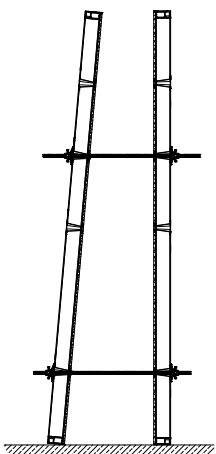

Height difference in formwork
 PLATINUM 100 tie rod
 0.5 mm/10 cm wall thickness
 DW 20 tie rod = 1.2 cm/10 cm
 wall thickness

Formwork inclined on both sides
 PLATINUM 100 tie rod = $2 \times 2.5^\circ$
 DW 20 tie rod = $2 \times 7^\circ$

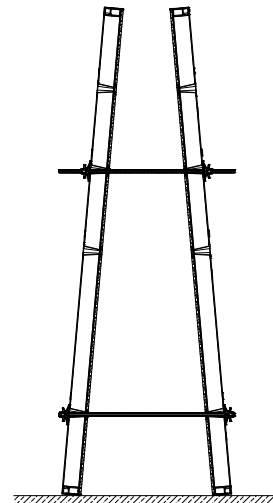

9 Length adjustments, corners



WARNING

Warning!

Always place ties through the adjustment!
Exceptions see page 68!

9.1 Length adjustments with universal connector (up to 15 cm)

Universal connector

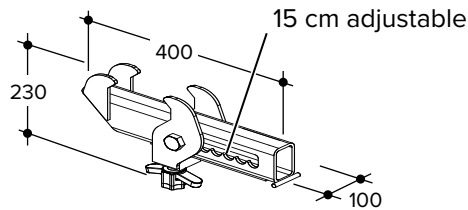

9.1.1 0 - 15 cm adjustment with timber

Adjustments starting from 0 cm up to 15 cm can be done on site with timber adjustments.

The universal connector connects in tension two PLATINUM 100 panels and the adjustment area up to 15 cm in alignment and without offsets.

Full size on site timber adjustment

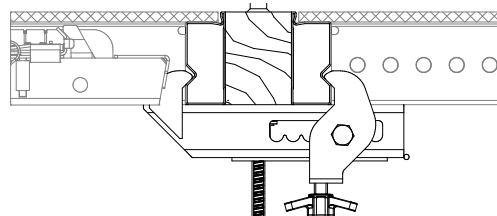
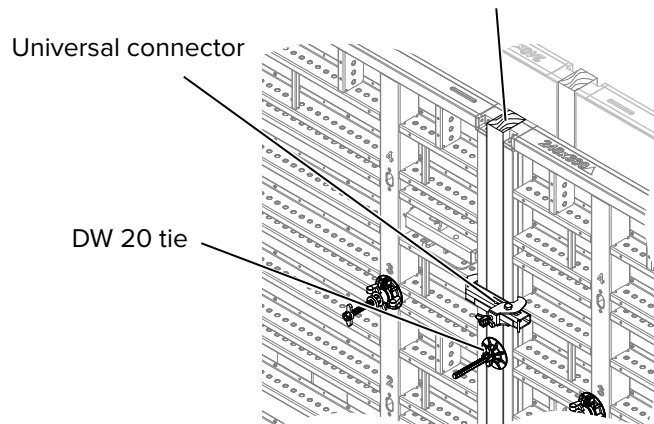

NOTE

Note!

300 cm panels must be connected with two universal connectors!
360 cm panels must be connected with three universal connectors!

9.1.2 Adjustment with the PLATINUM filler 5

Length adjustments of 5 cm are done by using the PLATINUM filler 5. The filler is placed between the PLATINUM 100 panels and fixed with the clamping screw. The universal connector connects the PLATINUM 100 panels and the length adjustment in tension, in alignment and without offsets.

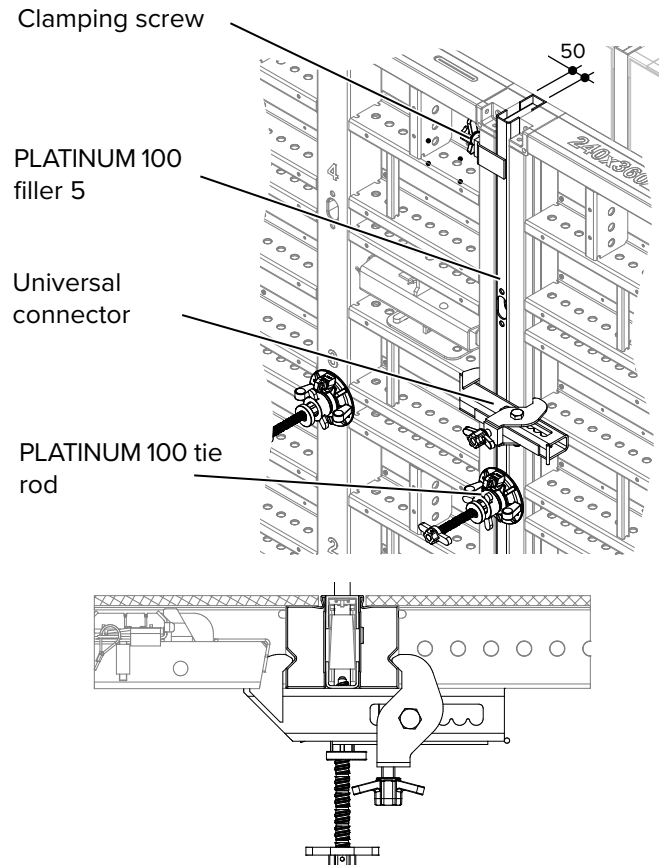

9.1.3 Adjustment with the PLATINUM filler 6

The 6 cm fillers are used at corners when the wall thickness has to be 9, 21, 24, 36, 39 or 51 cm. The filler is placed between the PLATINUM 100 panels and fixed with the clamping screw.

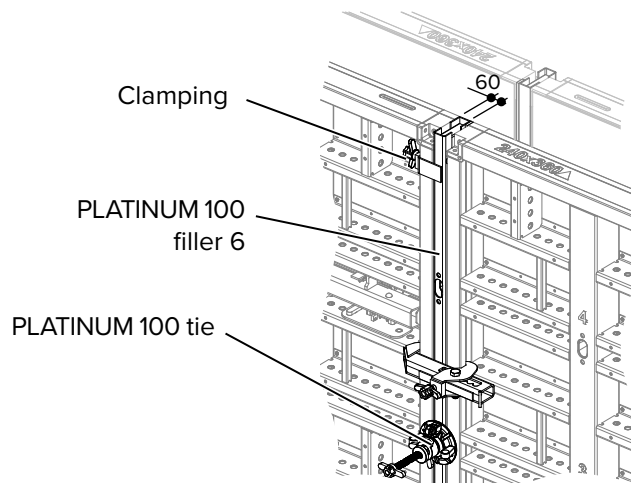

9.2 Length adjustments using waler 100 (15 - 45 cm)

Adjustments between 15 and maximum 45 cm need to be supported by using the waler 100 (prod. code 450764), two multi bolts and two MANTO tie nuts (prod. code 464600).

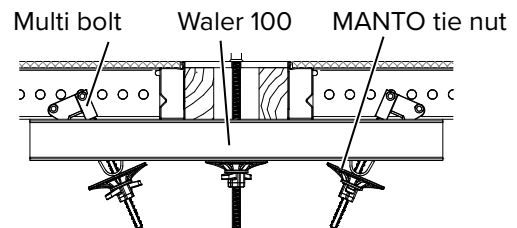
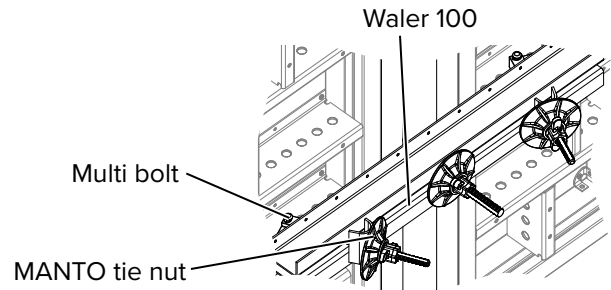
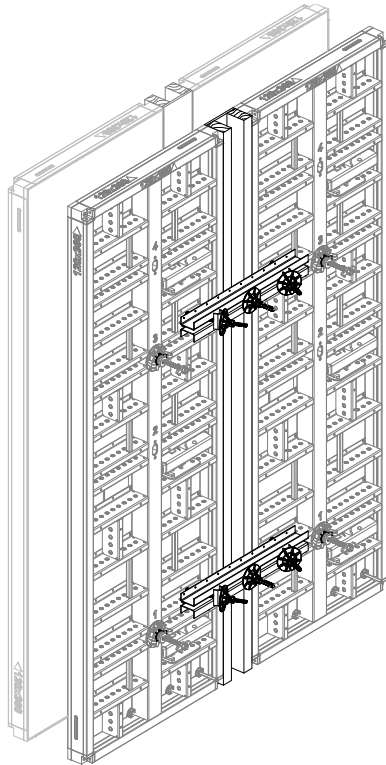

NOTE

Note!

A clever arrangement of the panels and adjustments allows to renounce adjustments >15 cm and so the use of the waler 100.

9.3 Adjustments without ties with hydrostatic load up to 90 kN/m² and up to 3.60 m formwork height

As a rule place ties in adjustments. With a smart combination of panels and connections additional ties in adjustment areas are not necessary. With all other panel combinations always place the ties in the adjustments!

Adjustment between two large panels

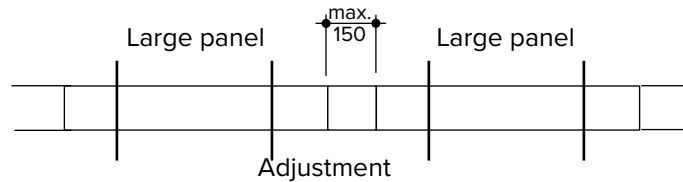

Adjustment between a large panel and a small panel

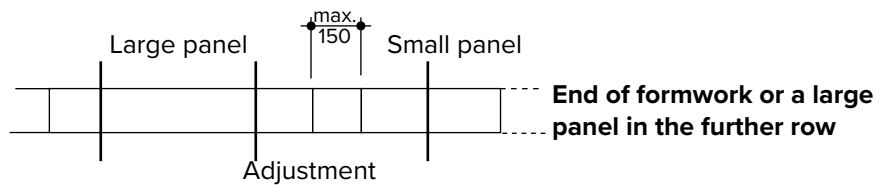

Adjustment between two small panels and adjacent large panels

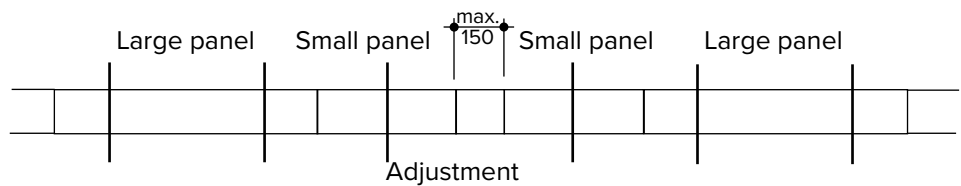

Panel width:

Large panel = 2.40 m

Small panel ≤ 1.20 m

**9.3.1 Formwork height 3.00 m
Hydrostatic load (75 kN/m²)**

Conditions:

1. Adjustment widths max. 15 cm
2. For panel arrangement see above
3. Place universal connectors in tie level.
4. The small panels that are placed at the adjustment must be connected to the large panels with aligning wedge clamps.

Example

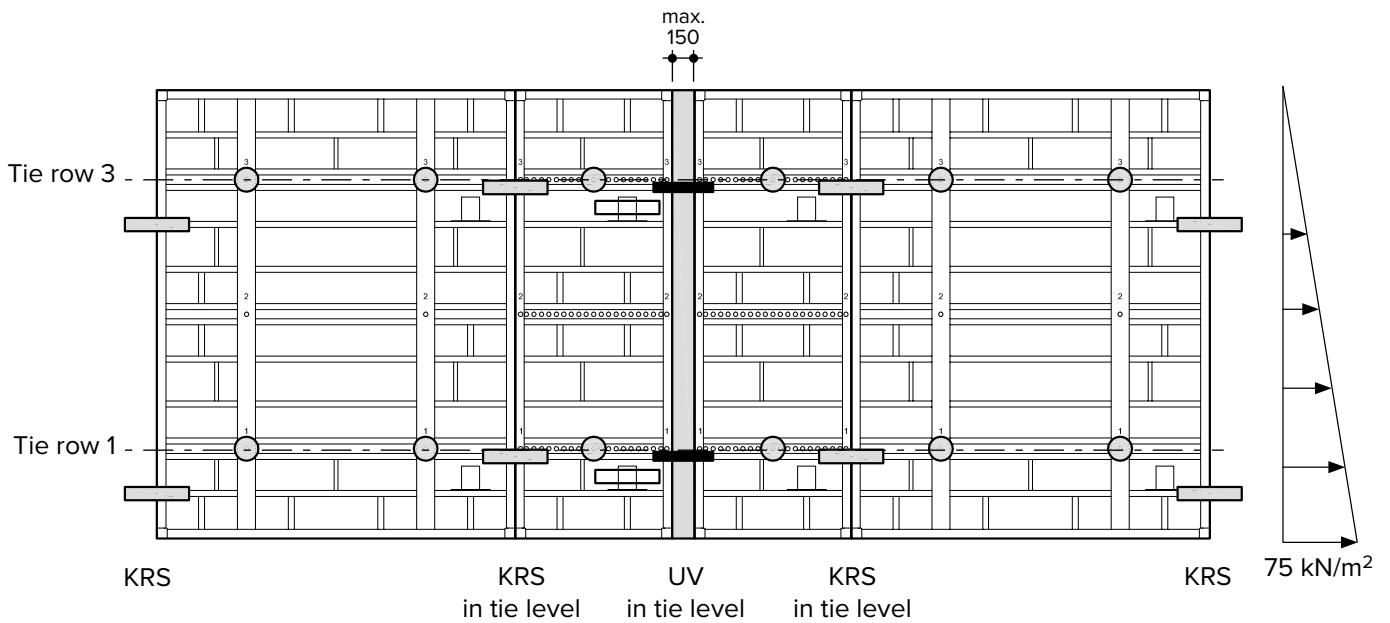

Legend:

-  KRS: Aligning wedge clamp
-  UV: Universal connector
-  Tie

9.3.2 Formwork height 3.60 m Hydrostatic load (90 kN/m²)

Conditions:

1. Adjustment widths max. 15 cm
2. For panel arrangement see page 68
3. Place universal connectors in tie level.

Example

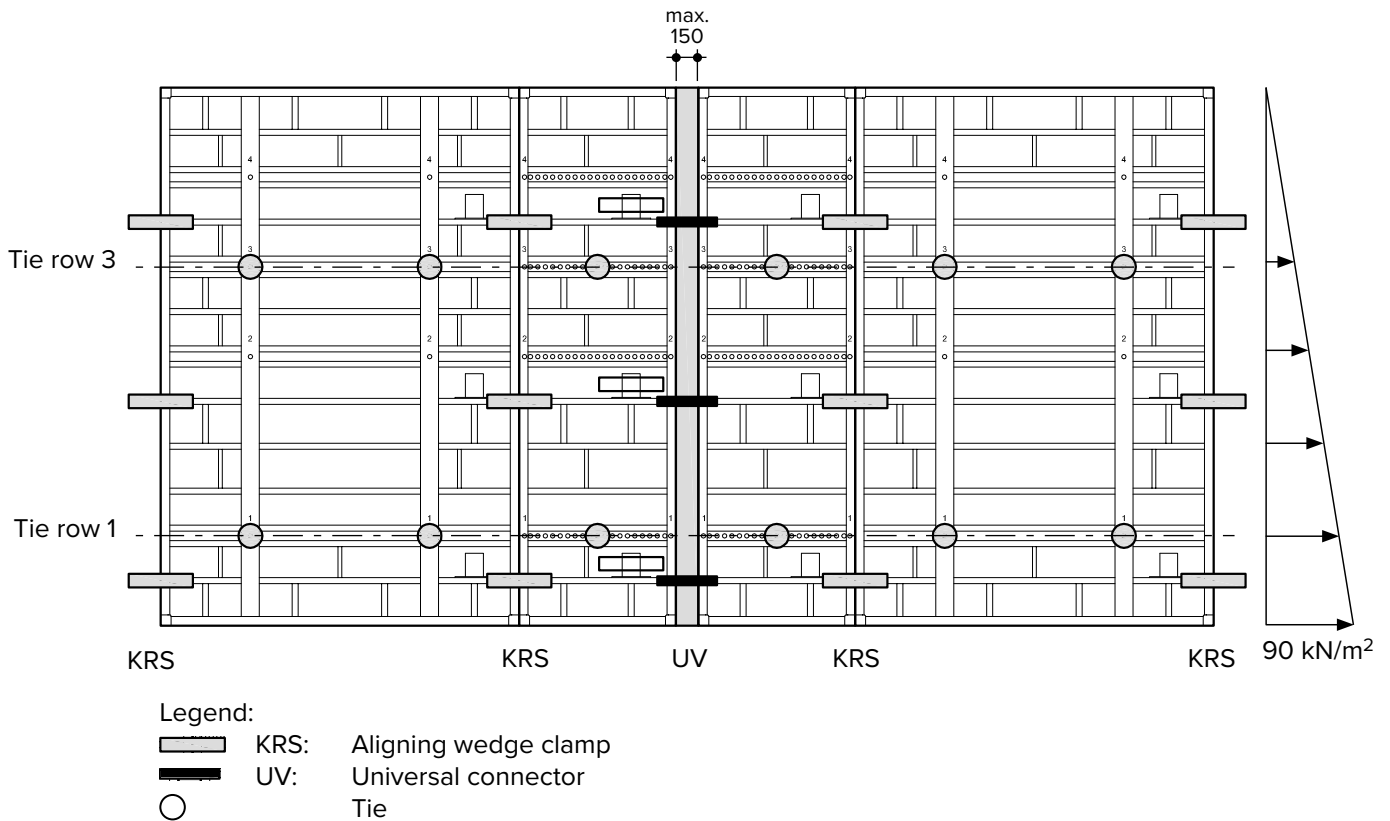

9.4 Full area load with 3.00 m panel height 100 kN/m²

Conditions:

1. Adjustment widths max. 15 cm
2. Always one large panel (240/300) at the beginning and one at the end of the panel assembly.
3. Place small panels at both sides of the adjustment.
4. Place universal connectors in tie level.
5. The small panels that are placed at the adjustment must be connected to the large panels with aligning wedge clamps.
6. Place an additional aligning wedge clamp at tie level in each panel joint to the large panels.
7. The max. widths of the panels directly adjacent to the small panels incl. adjustment must not exceed 2.25 m.
8. Do not use 120 cm panels in the adjustment.

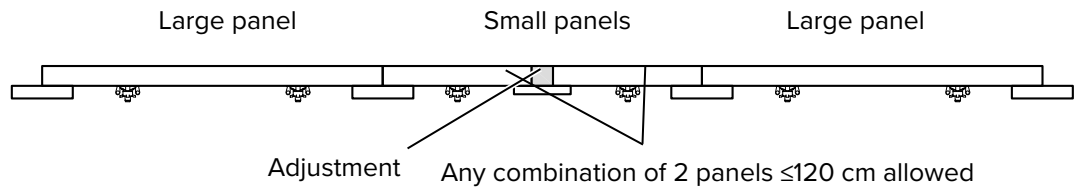

WARNING

Warning!

The max. widths of the panels directly adjacent to the small panels incl. adjustment must not exceed 2.25 m.

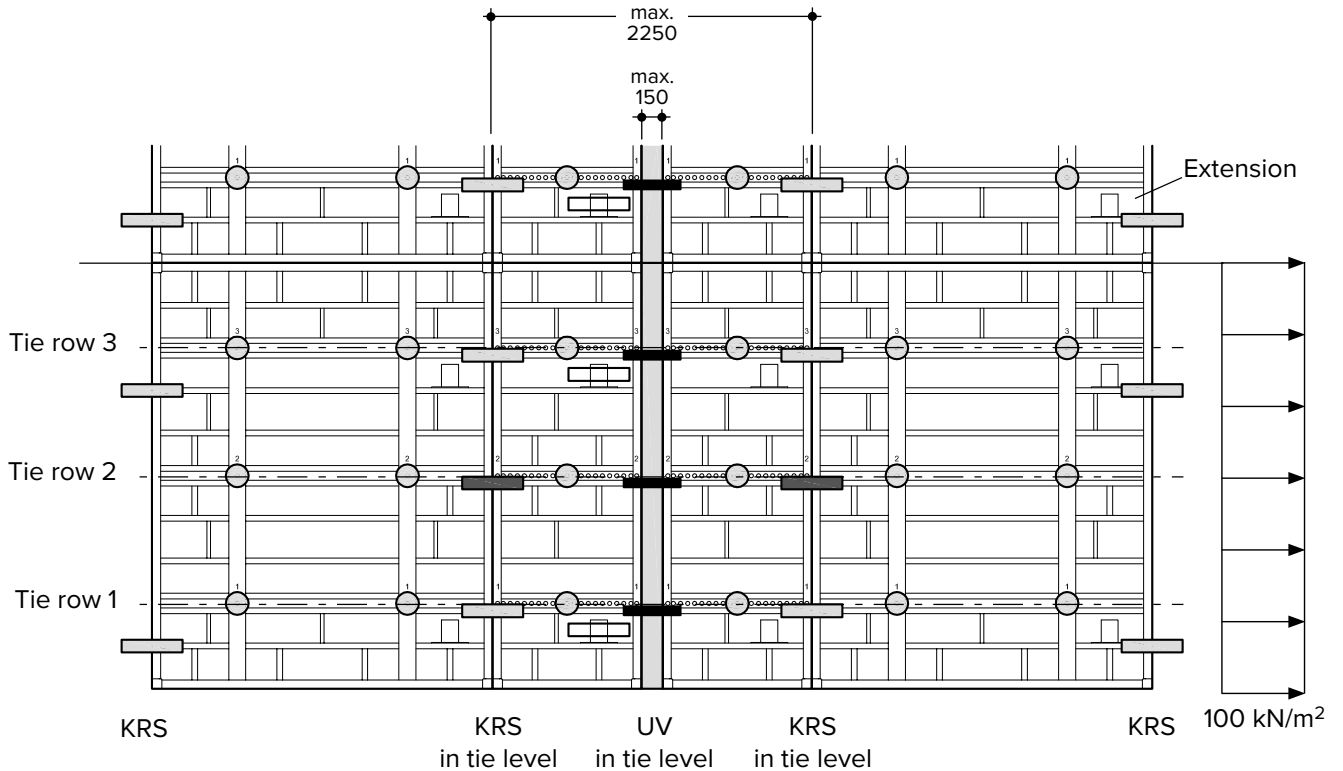

Legend:

- KRS: Aligning wedge clamp
- KRS: add. aligning wedge clamp
- UV: Universal connector
- Tie

Adjustments without ties at 3.60 m and 100 kN/m² full area load are not permitted!

9.5 90° Corners

The PLATINUM 100 inside corner 90°, with a side length of 45 cm each, is equipped with tie locations at the edge profiles.

The PLATINUM 100 inside corner 90° also provides a spindle for accurate adjustment. The spindle has a marking at 90° for easy pre-adjustment. The corner is also equipped with a hammer-operated, quick-release mechanism for fast and easy stripping without need for operating the spindle.

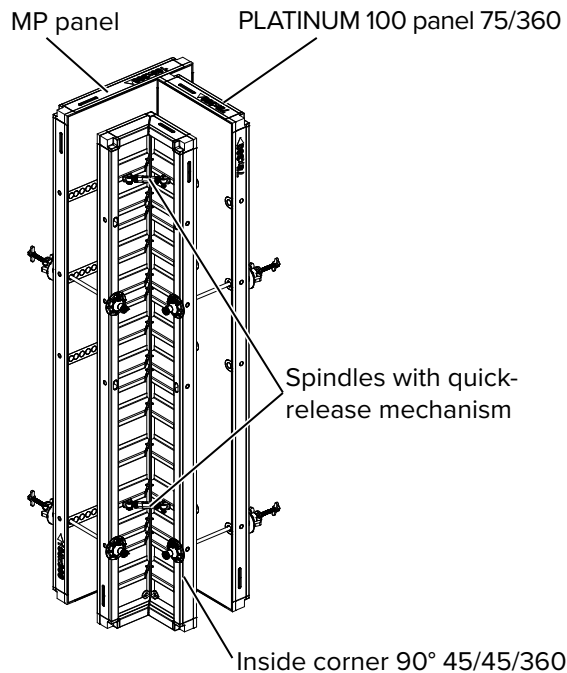

Advantages:

- Accurate 90° setting.
- Quick-release mechanism for fast and easy assembly and stripping and reduction of wear and tear.

The outer corners are formed by using PLATINUM 100 panels with cross holes in their edge profiles and MP panels in increments of 5 cm. The panels are connected with MP bolts. The panel has three tying points: two at the edges, for simple corner tying, and one in the middle for a continuous tie rod pattern. The middle tie point can be fitted with a PLATINUM 100 dummy cone when it is not used. This achieves a continuous tie rod pattern.

Advantages:

- Simple corner solution.
- Continuous tie pattern.

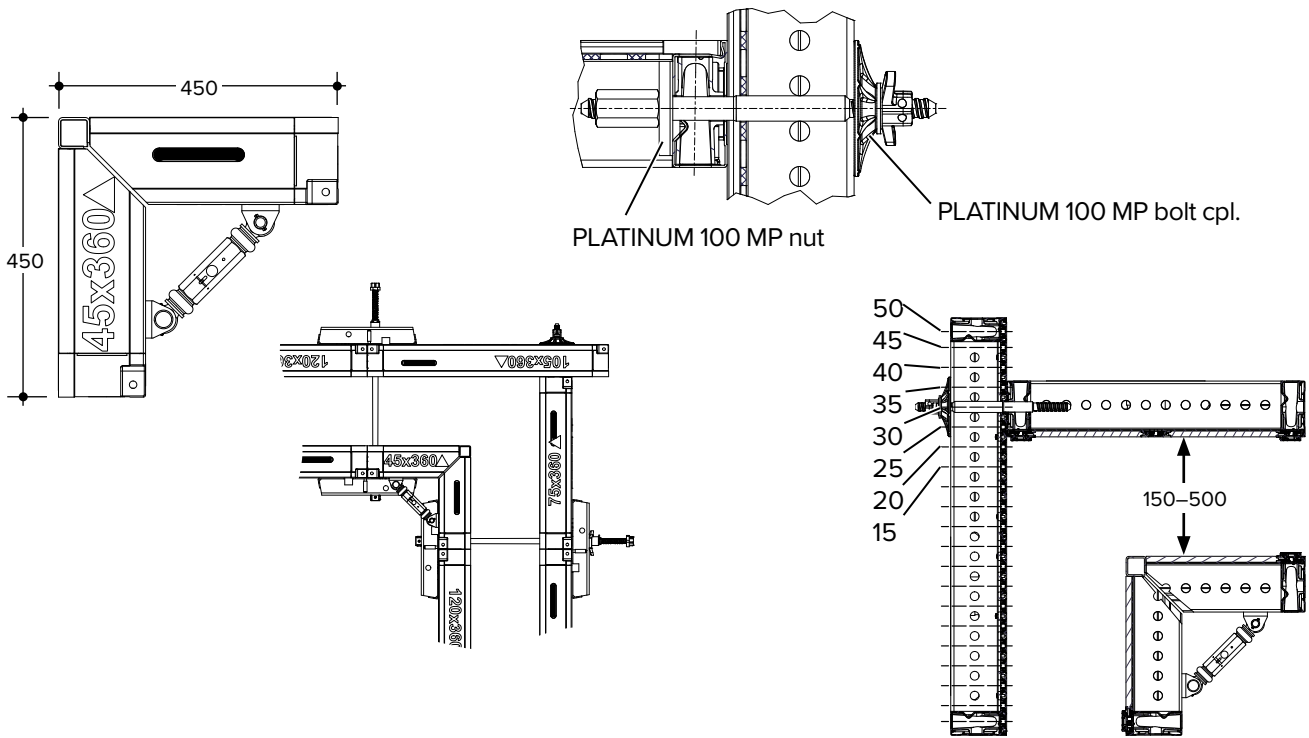

NOTE

Note!

Always use 3 MP bolts:
 For 360 cm: tie position 1, 2, 4
 For 300 cm: tie position 1, 2, 3

9.5.1 Corners with PLATINUM 100 panels

Wall thickness of 15 cm up to 50 cm in steps of 5 cm.

With PLATINUM 100 tie rod

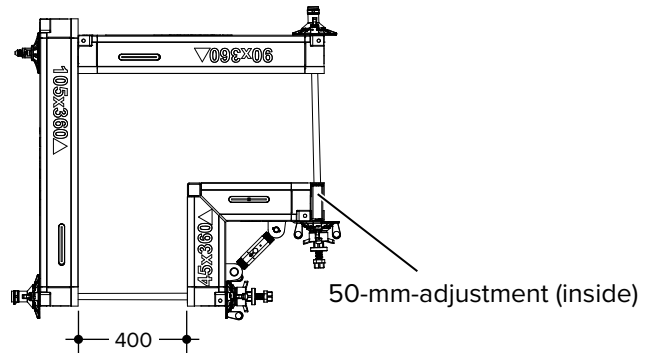
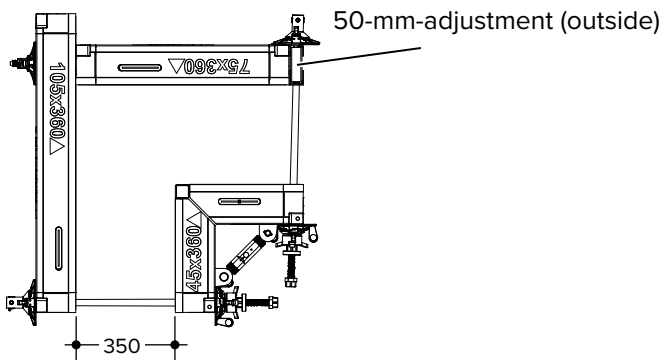
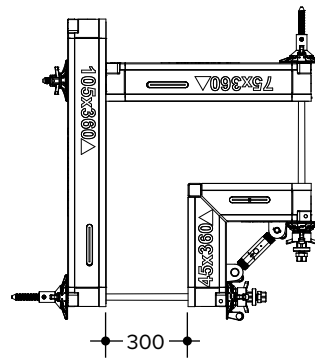
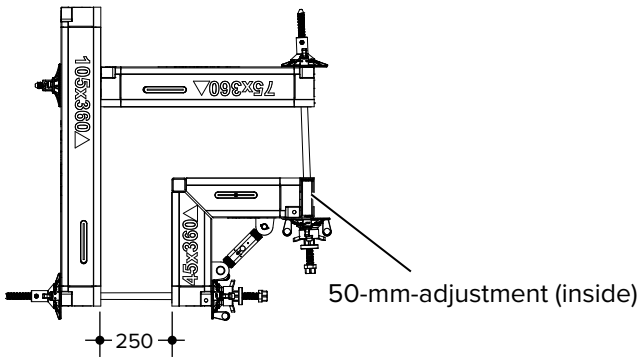
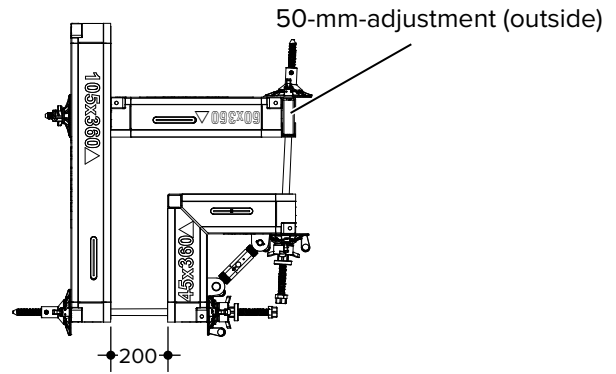
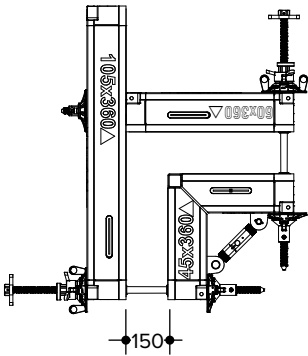

With DW 20 tie rod

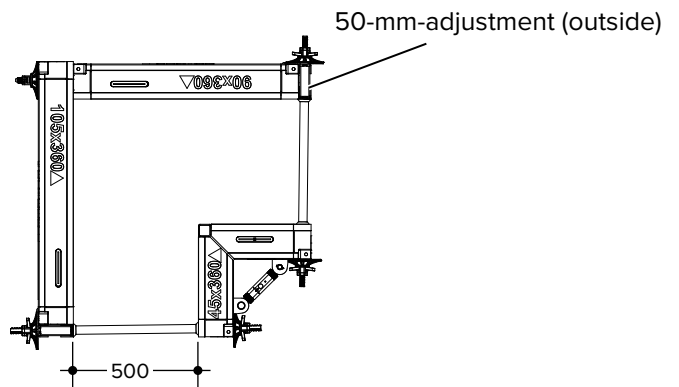
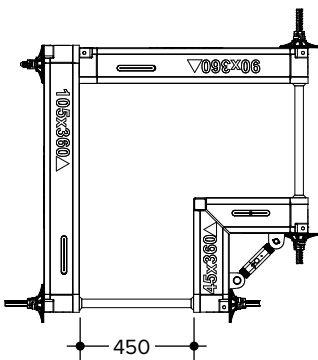

Wall thickness of 9 cm up to 51 cm

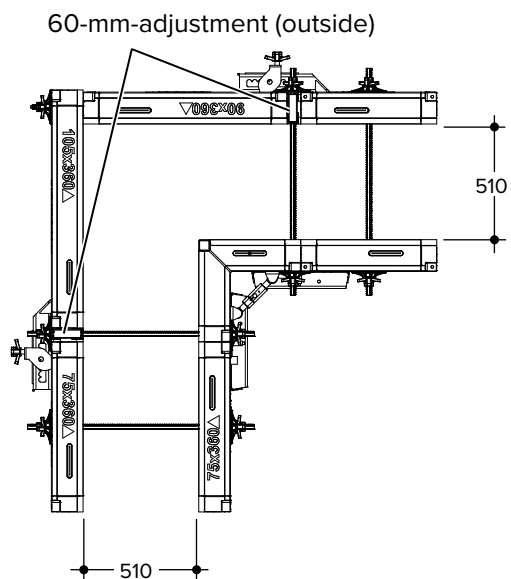
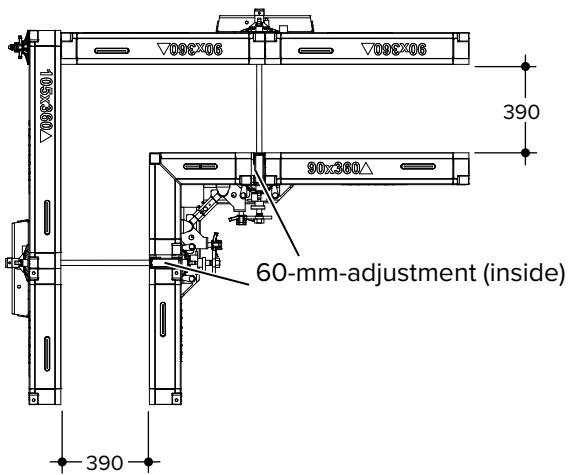
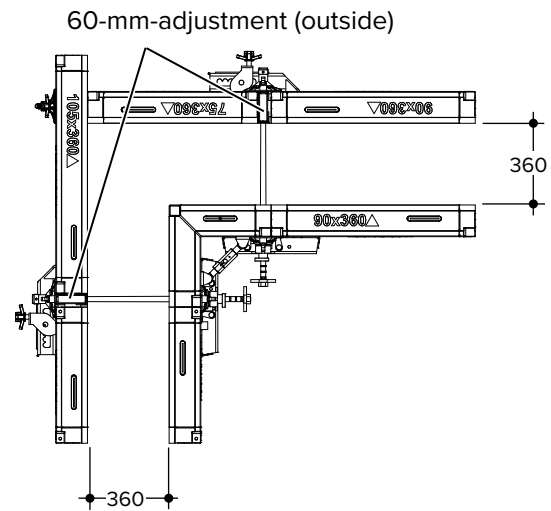
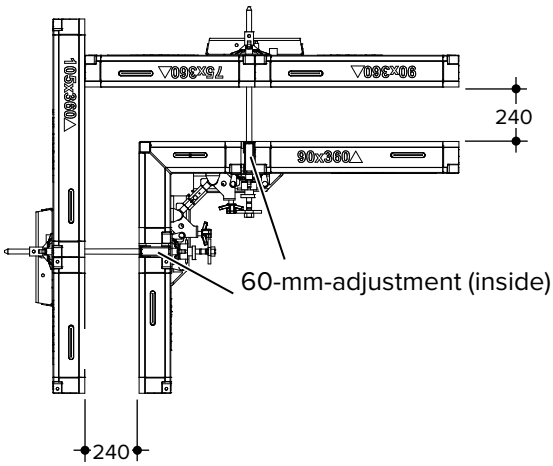
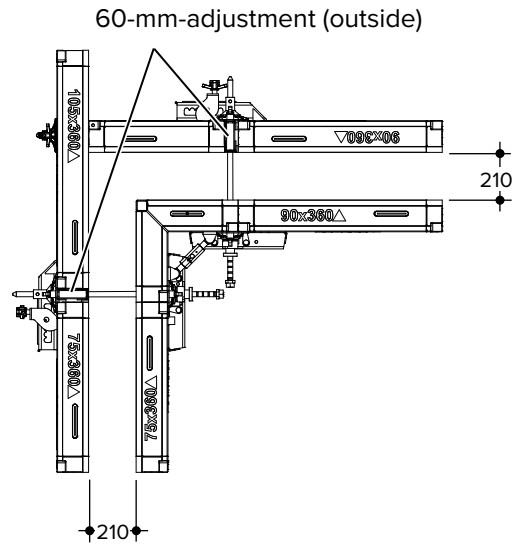
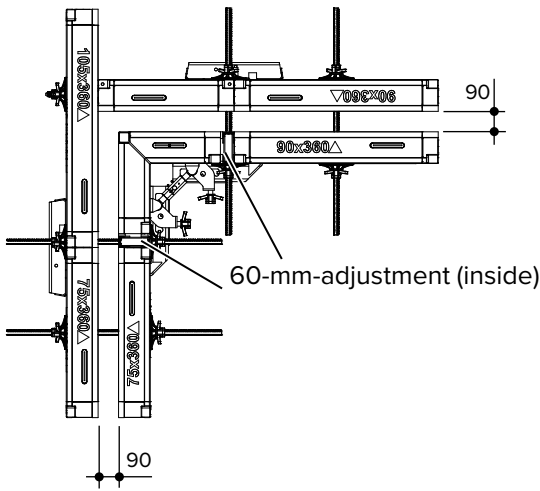

9.6 Angled Corners

With the PLATINUM 100 inner hinged corner and the PLATINUM 100 outer hinged corner it is possible to form oblique-angled corners, starting with a minimum of 75° up to a maximum of 165°. The adaption of the wall thickness is realized with length adjustments.

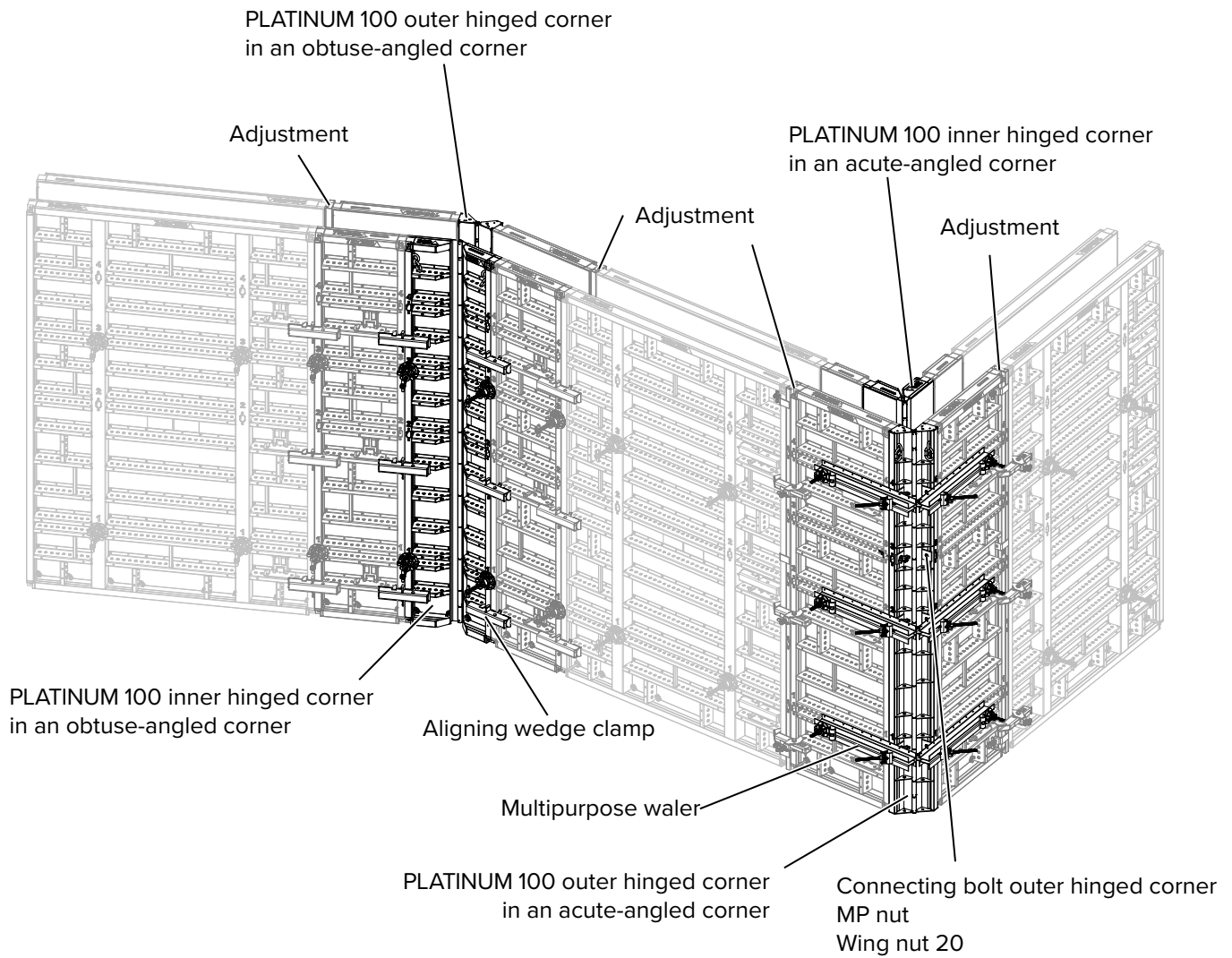

WARNING

Warning!

Arrange additional aligning panel clamps at horizontal element connections with increased tension loads such as outer corners and stopends (see on page 82).

9.6.1 Outer corner

In standard configuration the outer corner is always connected to a MP panel. The standard connection for the outer corner to the MP panel is realized with connection bolts outer corner, wing nuts and MP nuts. Insert ties as close to the joint as possible to safe additional stiffening (girders).

NOTE	<p>NOTE!</p> <p>Always use 3 MP bolts: For 360 cm: tie position 1, 2, 4 For 300 cm: tie position 1, 2, 3</p>
-------------	---

If the distance between outer corner and 1st tie is ≥ 36.5 cm then multipurpose walers or girders must be connected.

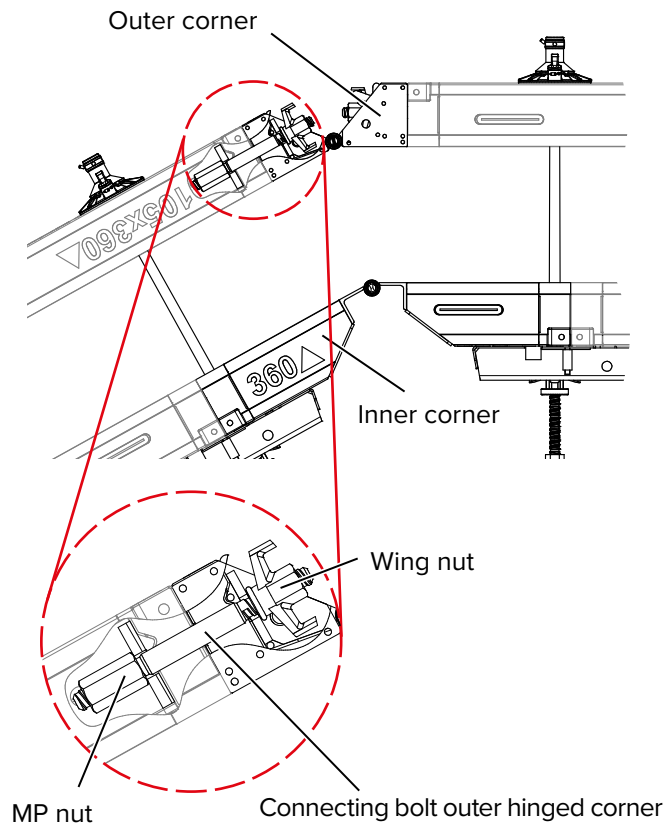

9.6.2 Inner corner

Acute-angled inner corners are always connected with universal connectors. Obtuse-angled corners can also be connected with aligning wedge clamps.

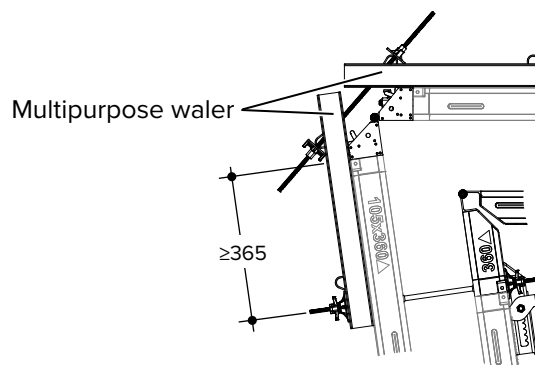

Length adjustments, corners

The inner corner is equipped with 2 tie locations. According to the wall thickness and the angle choose the right tie position. Insert ties as close to the joint as possible to safe additional stiffening (girders).

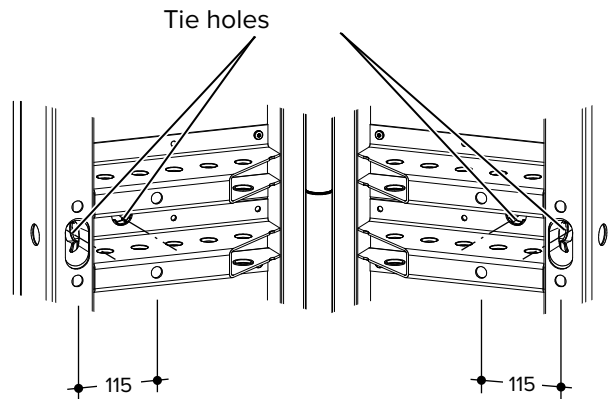

NOTE

Note!

Depending on the situation a classic DW20 tie must be used at one leg.

9.7 Obtuse-angled corners

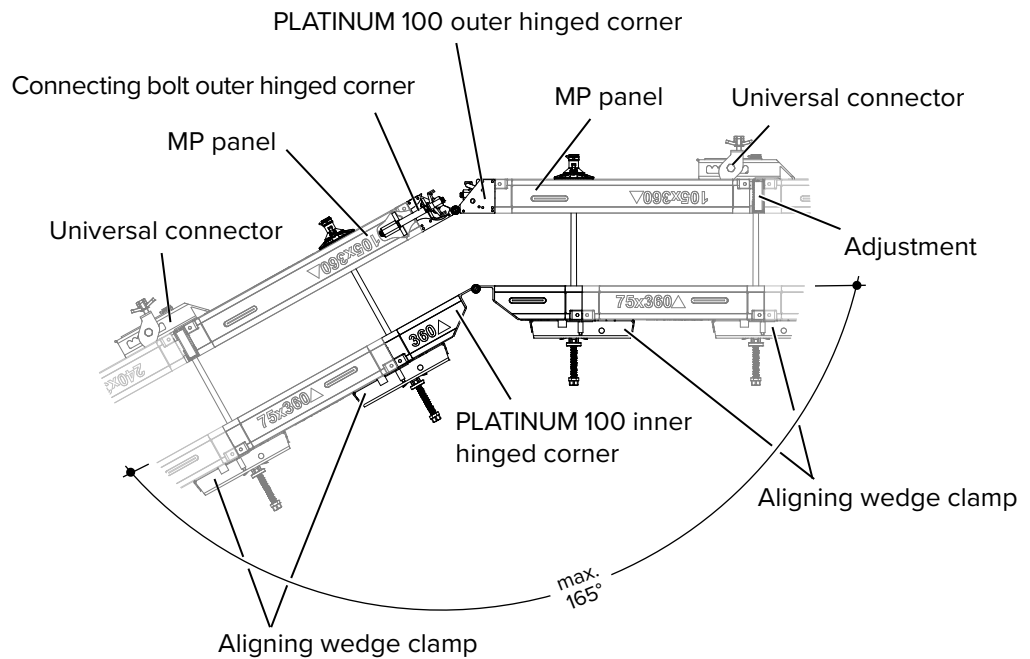

NOTE

Note!

Always use 3 MP bolts:
For 360 cm: tie position 1, 2, 4
For 300 cm: tie position 1, 2, 3

9.8 Acute-angled corner

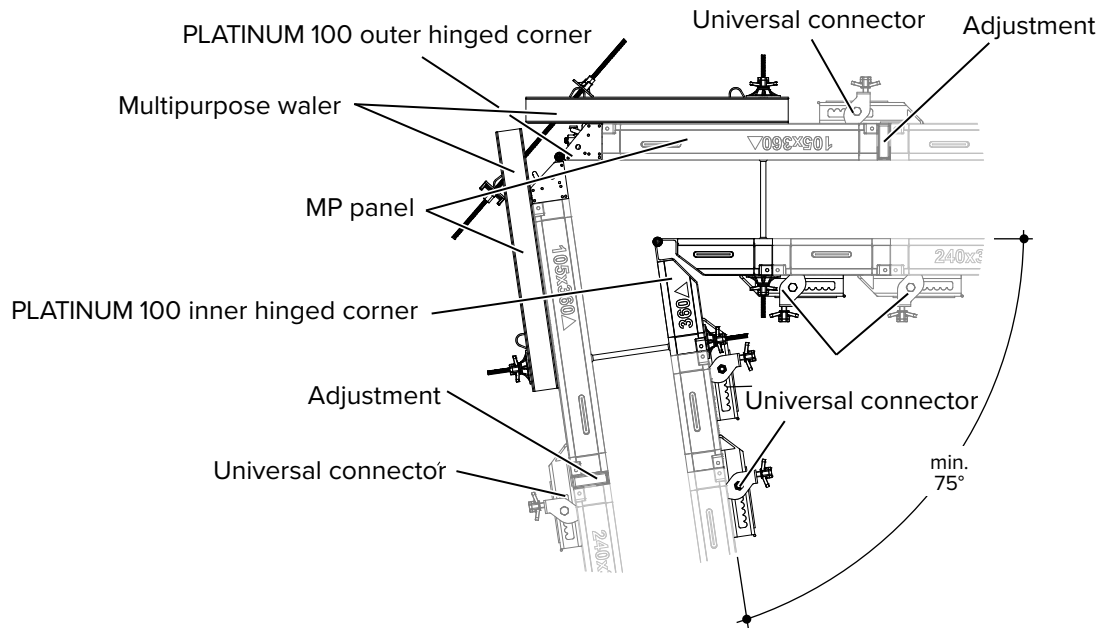

Adjustment range of the PLATINUM 100 inner hinged corner and the PLATINUM 100 outer hinged corner

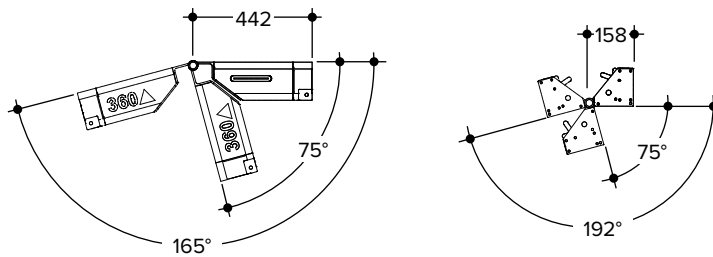

9.9 T-walls with the inside corner 90°

T-walls with up to 40 cm thickness can be easily formed in 5 cm increments without additional parts.

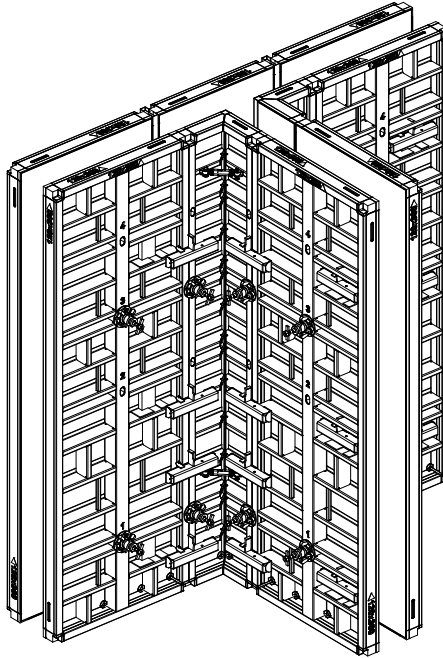

Example:

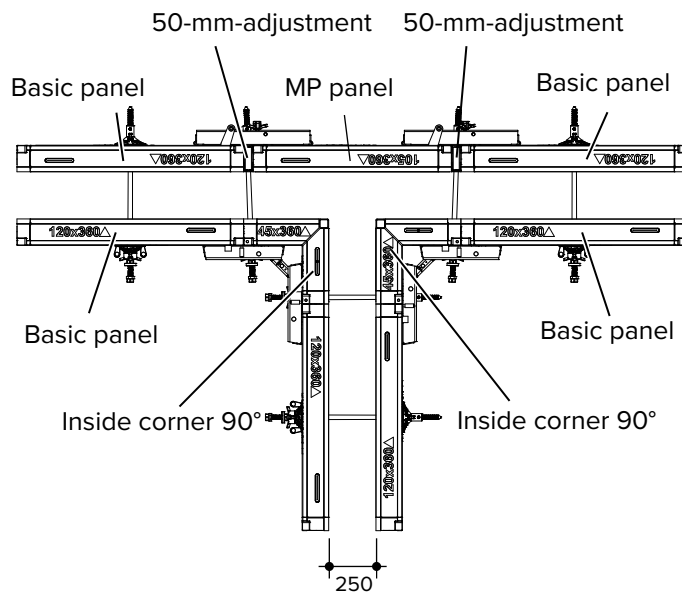

NOTE

Note!

At projecting areas it may be necessary to fix the formwork by appropriate measures.

9.10 Wall connection with length adjustment

PLATINUM 100 panels can be directly tied to an opposing MP panel.

Advantage:

Direct tying without the need for on-site drilling or labor intensive on-site formwork solutions.

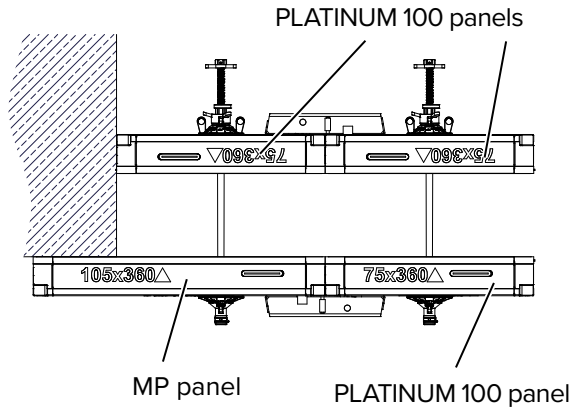

NOTE	<p>Note! At projecting areas it may be necessary to fix the formwork by appropriate measures.</p>
-------------	--

9.11 T-walls and pilasters with MP inside corners

Pilasters

The single-piece MP inside corner is used to form pilasters with the system in 5 cm increments. The stripping hinge provides a clearance of about 2 cm during stripping, allowing to strip and transport the entire formwork unit between two pilasters in one piece.

Advantage:

Fast stripping and transport as one piece with a crane.

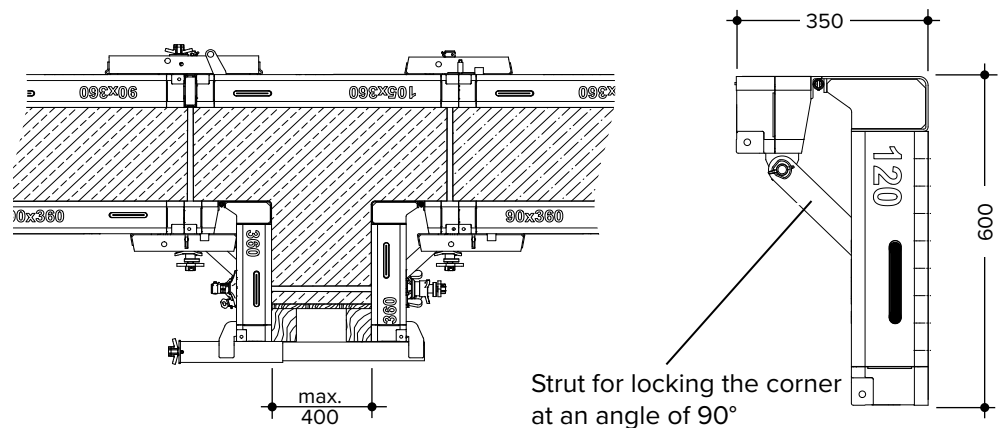

NOTE	<p>Note! Walls thicker than 40 cm require an additional tie through the bulkhead.</p>
-------------	--

Wall offsets

The MP inside corners and MP panels, with their 5 cm tie point pattern, allow for simple system solutions for wall offsets. There is no need for additional on-site formwork solutions.

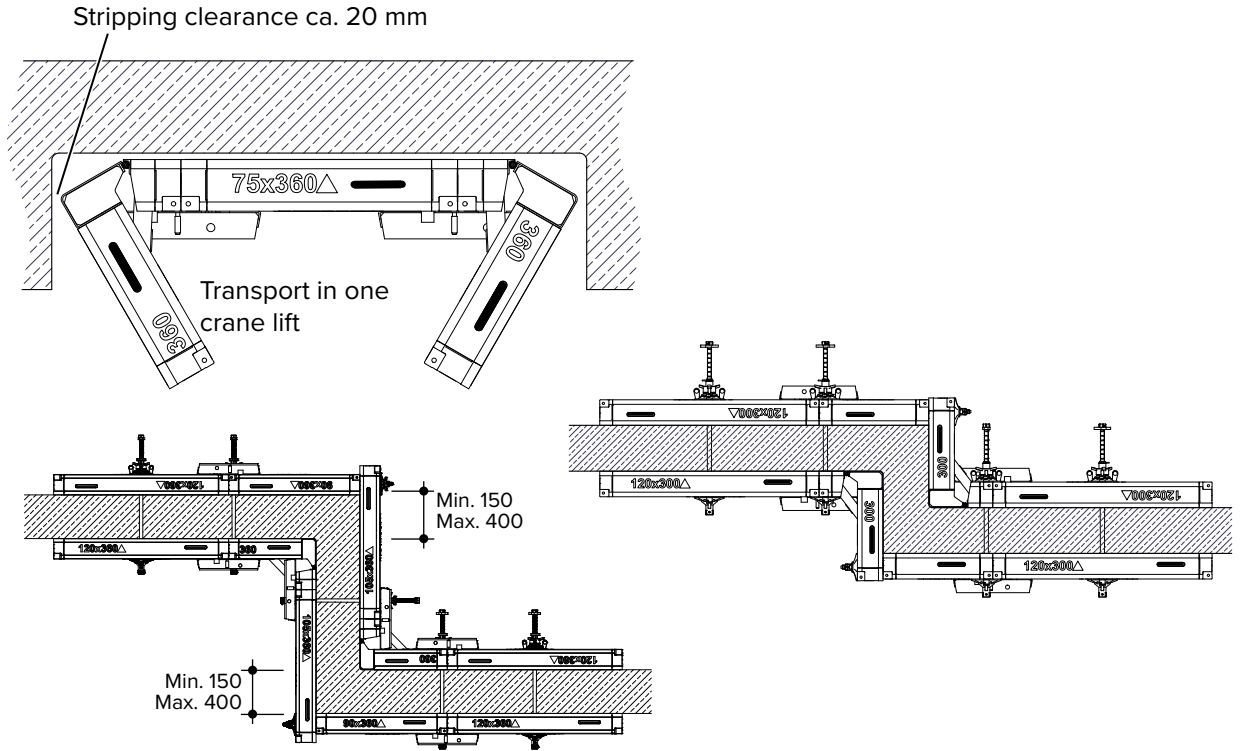

NOTE

Note!

Due to the high number of possibilities, use the adjacent pictures as examples.

9.12 Panel connections with increased tensile loads

Areas with increased tensile loads in "area 1" require additional aligning wedge clamps as per table below.

Outer corners up to 42.5 cm wall thickness

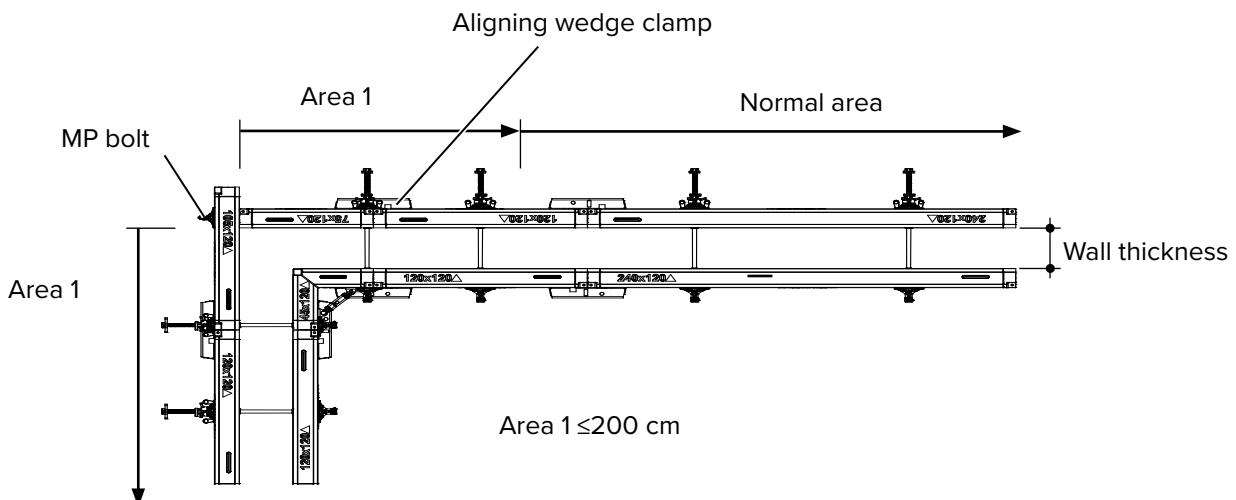

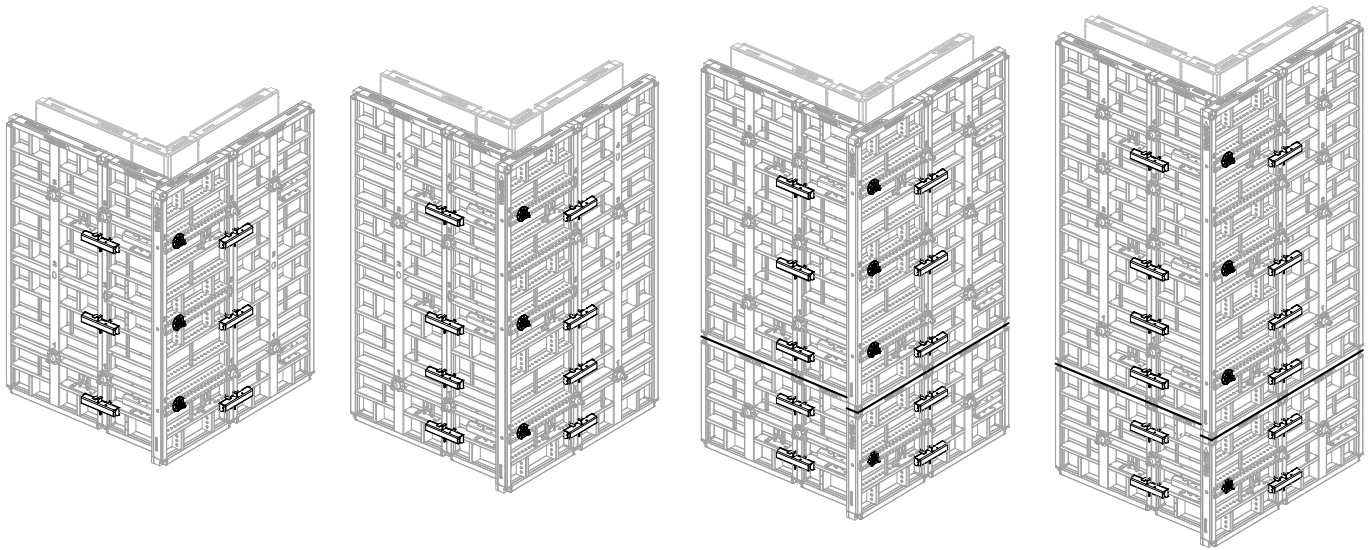

Formwork height [cm]	300	360	420	480
Panel arrangement	300	360	120 + 300	120 + 360
No. of aligning wedge clamps	3	4	2 + 3	2 + 4
No. of MP bolts	3	3	1 + 3	1 + 3

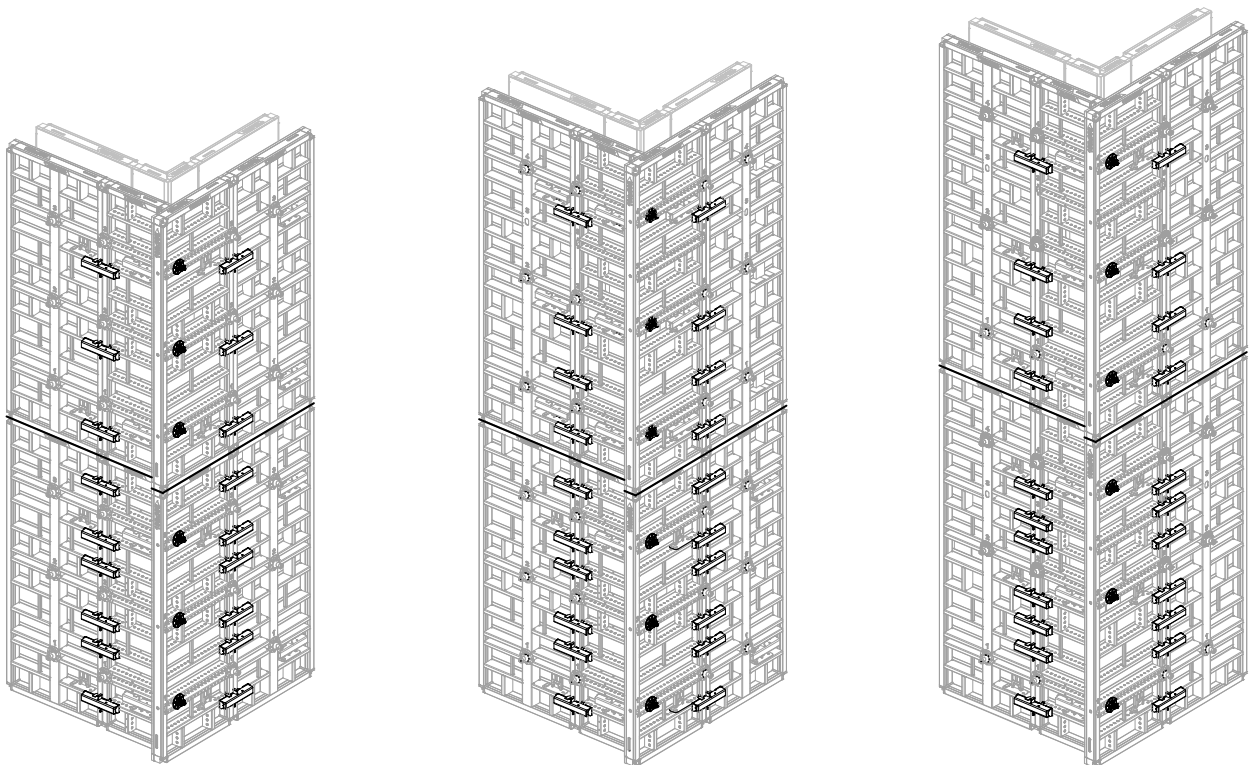

Formwork height [cm]	600	660	720
Panel arrangement	300 + 300	300 + 360	360 + 360
No. of aligning wedge clamps	6 + 3	6 + 4	7 + 4
No. of MP bolts	3 + 3	3 + 3	3 + 3

Bulkheads

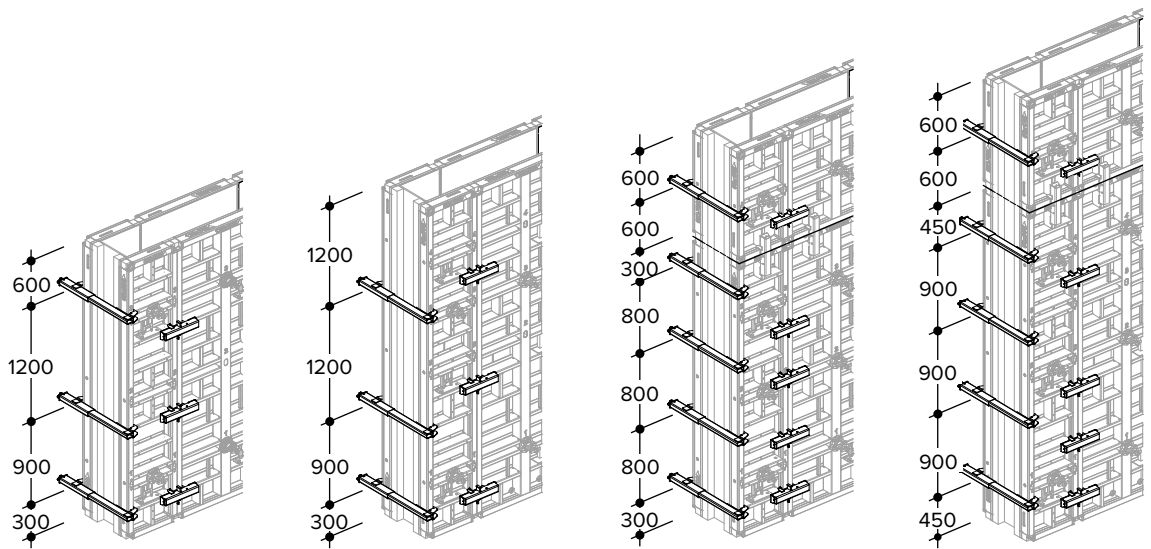
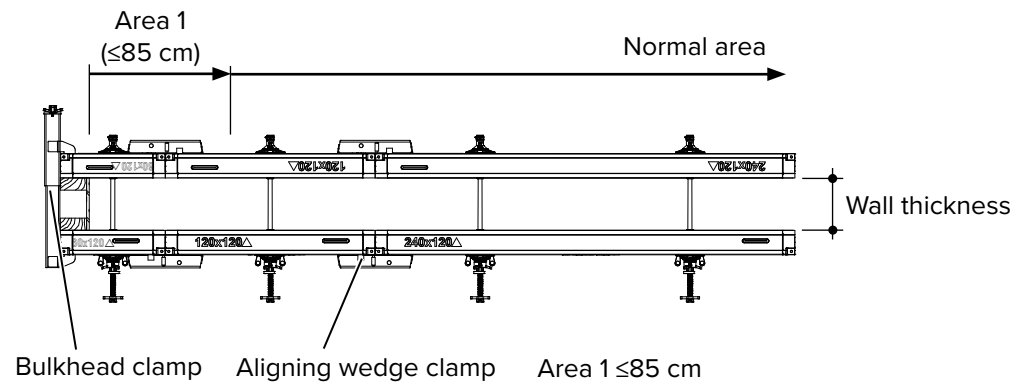

Formwork height [cm]	300	360	420	480
Panel arrangement	300	360	300 + 120	360 + 120
No. of aligning wedge clamps	3	3	4 + 1	4 + 1
No. of bulkhead clamps	3	3	4 + 1	4 + 1

NOTE

Note!

Increased tensile loads require additional aligning wedge clamps on both sides of the formwork! All values are valid for concrete with standard friction coefficient of $\mu=0.2$ between concrete and formwork. Concrete with non-typical lower consistency requires separate calculations.

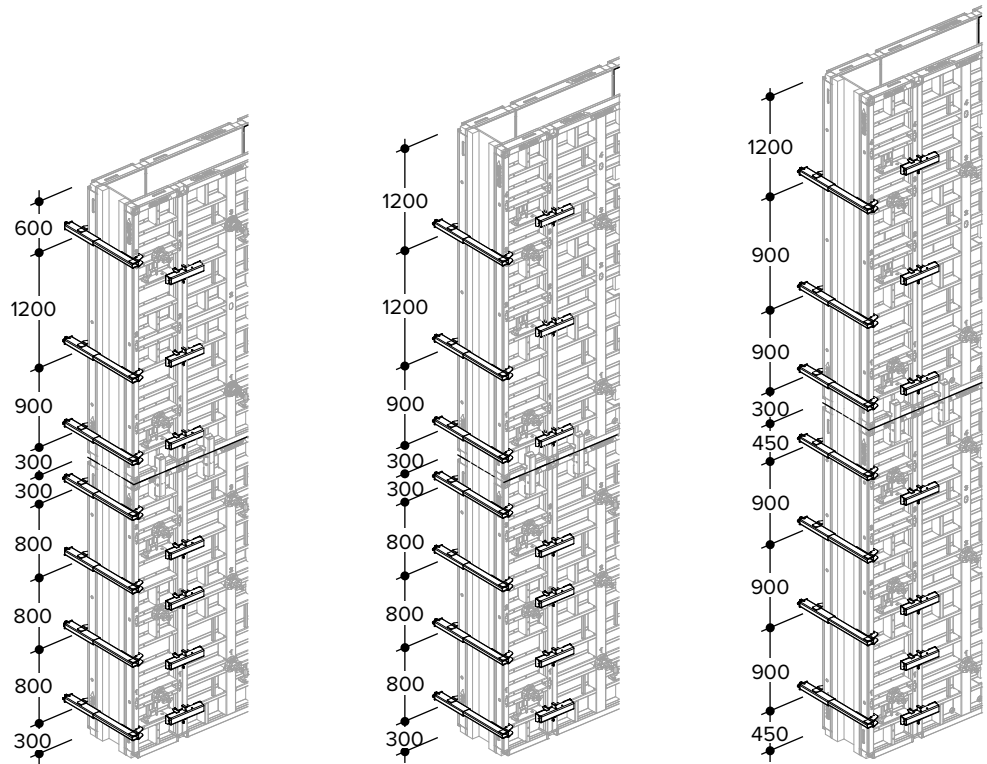

Formwork height [cm]	600	660	720
Panel arrangement	300 + 300	300 + 360	360 + 360
No. of aligning wedge clamps	4 + 3	4 + 3	4 + 3
No. of bulkhead clamps	4 + 3	4 + 3	4 + 3

Positioning of PLATINUM 100 bulkhead clamps

It is recommended to attach the bulkhead clamps over the panel ribs.

Maximum spacing of the bulkhead clamps with hydrostatical concrete pressure (formwork height 300 cm and 360 cm)

Starting from the bottom, the first bulkhead clamp is positioned at 30 cm. The second bulkhead clamp is mounted 90 cm above the first bulkhead clamp. The third clamp is positioned 120 cm above the second.

This arrangement is optimized for hydrostatical concrete pressure.

Maximum spacing of the bulkhead clamps with 100 kN concrete pressure (stacked)

Starting from the bottom, the first bulkhead clamp is positioned at 30 cm for 300 cm high formwork and 45 cm for 360 cm high formwork. The following bulkhead clamps are mounted with a spacing of 80 or 90 cm each. At the top panel the bulkhead clamps can be mounted as described above for hydrostatical concrete pressure.

Design details:

- 100 kN/m², 40 cm wall thickness.
- At least four clamps for each 300 cm and three for 360 cm panel.
- Minimum number of loose parts due to the combination of the dry end tie and bulkhead support in one part.
- Light weight.

300 cm high formwork panels

Concrete pressure 100 kN/m²

hydrostatical concrete pressure 75 kN/m²

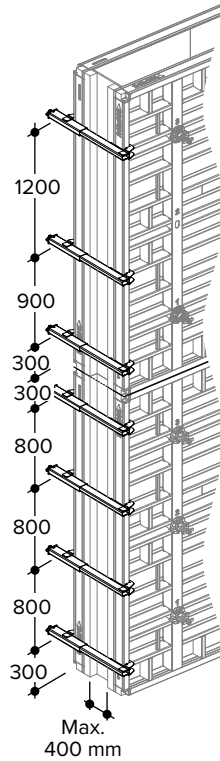
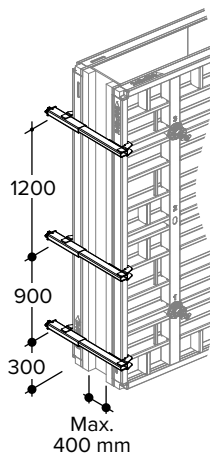

360 cm high formwork panels

Concrete pressure 100 kN/m²

hydrostatical concrete pressure 90 kN/m²

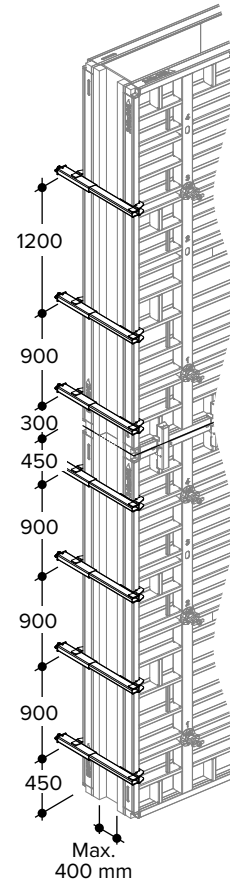
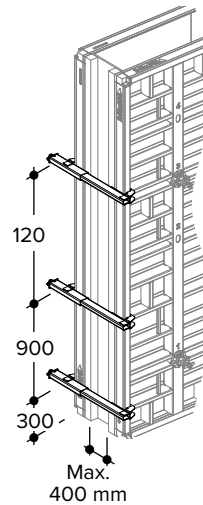

9.13 Window and door boxouts

It is necessary to add spreaders, which are capable to withstand compressive loads at panels with centrally arranged tie holes at window or door boxouts with asymmetrical loads. The on-site spreaders must be placed in each tie row and at the top and bottom of the panel edge within the boxout.

Example for a boxout

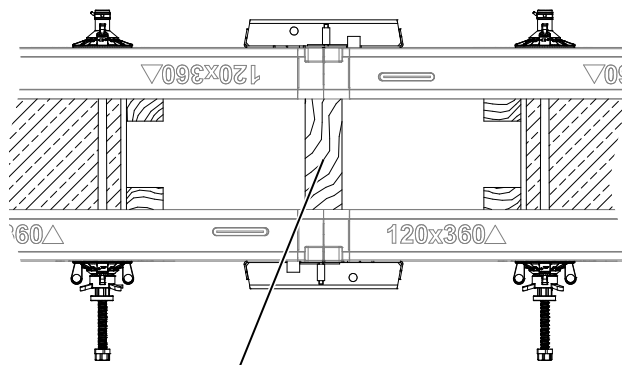

Pressure resistant, on-site spreader e.g. plank, t = 6 cm

NOTE

Note!

The spreaders that must withstand compressive loads (e.g. plank, t = 6 cm) at the panel joint must be added in each tie row as well as at the top and bottom panel edge.

10 Column formwork

The PLATINUM 100 MP panels can be used to form windmill-type rectangular and square columns in 5 cm increments with a side length of 15 to 90 cm without additional ties.

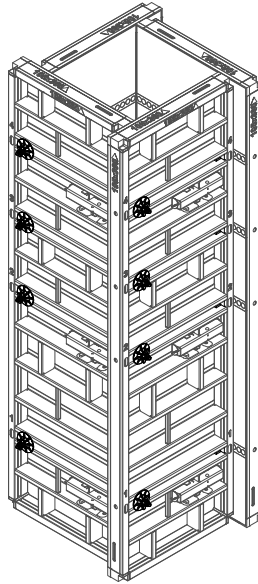

NOTE

Note!

For statical reasons, 3 MP bolts are necessary for 3.6 m high columns. When no chamfer strips are used it is recommended to use 4 MP bolts and turn the panel upside down for optical reasons.

10.1 PLATINUM 100 MP panel

Example: column 15 x 60 cm

Side length 15–90 cm

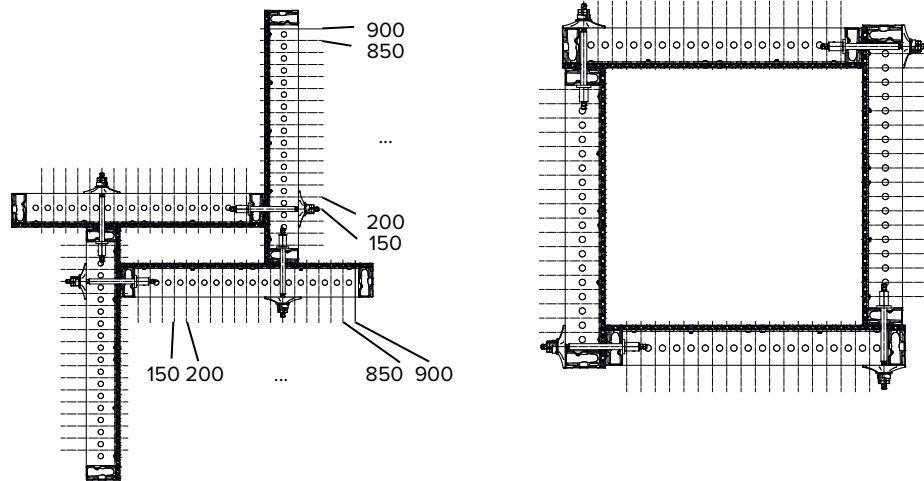

Example: column 90 x 90 cm

Detail: connecting the MP panel by using the MP bolt and MP nut

Top concrete surface due to the built-in plastic strip and flush PLATINUM 100 closing plugs.

Detail: Plastic strip of the MP panel

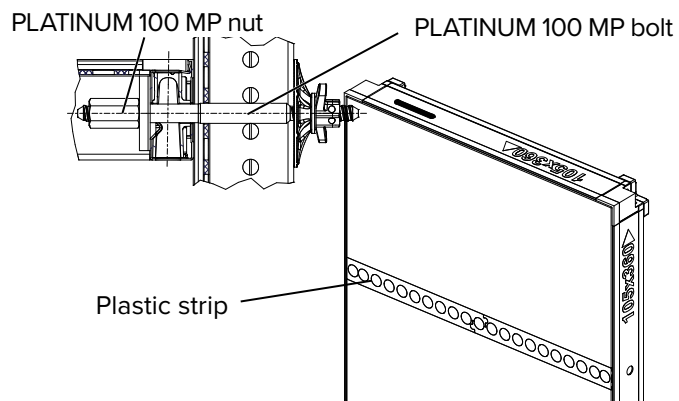

11 Bulkhead formwork

There are three solutions to form bulkheads:

- With MP-panels in combination with panels that have additional tie holes in the edge profile in 5 cm increments up to 75 cm wall thickness and without rebar penetrations.
- With flexibly arranged PLATINUM 100 bulkhead clamps and on-site bulkhead forms up to 40 cm wall thickness.
- With flexibly arranged walers, PLATINUM 100 multi bolt, dry end ties and on-site bulkhead forms for walls thicker than 42.5 cm.

11.1 With PLATINUM 100 MP panels

The MP panels are connected to wall panels with cross holes in the edge profiles using the PLATINUM 100 MP bolt and MP nut. This method for bulkheads is usually used for straight walls without further rebar connections or other built-in parts. Wall thicknesses in the range of 15 to 75 cm can be formed with the MP-panels in 5 cm steps.

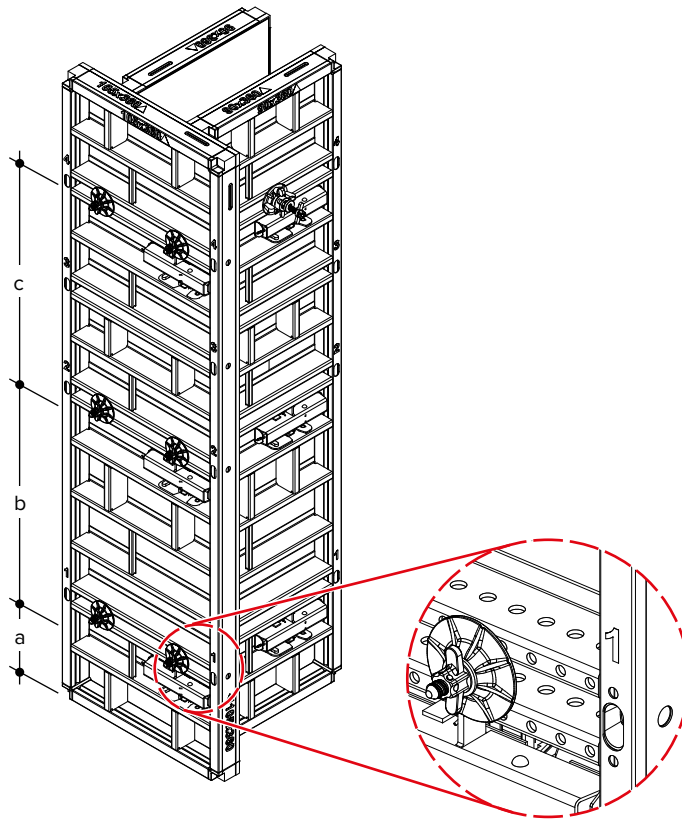

Top view

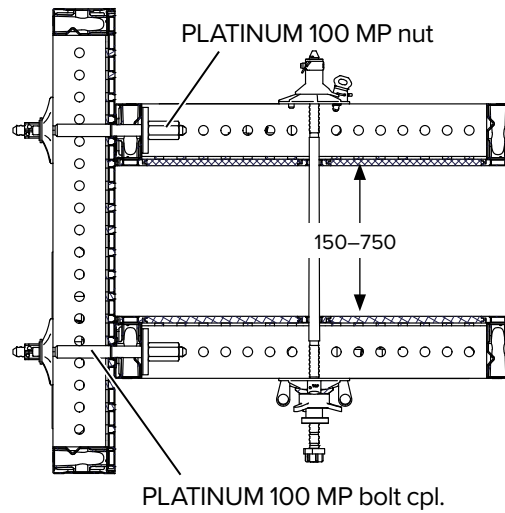

NOTE

Note!

Follow chapter *Panel connections with increased tensile loads* on page 82!

NOTE

Note!

Walls up to 42,5 cm thickness can be created using the PLATINUM 100 tie rod G1.
 Walls up to 40,0 cm thickness can be created using the PLATINUM 100 tie rod G2.
 Larger wall thicknesses can only be created using DW 20 tie rods.

Positioning of the connection points (three per 3.60 m height).

	a	b	c
Panel height 3.6 m	60 cm	120 cm	120 cm
Panel height 3.0 m	60 cm	90 cm	90 cm

11.2 With the bulkhead clamp

The PLATINUM 100 bulkhead clamp is used to form bulkheads of 15.0 up to 42.5 cm thick walls without additional loose connection parts. This solution for the forming of bulkheads with on-site timber formwork is typically used when rebars need to penetrate the bulkhead. The PLATINUM 100 bulkhead clamp combines the function of supporting the bulkhead formwork and the function of a dry end tie in a single part. The bulkhead clamp can be flexibly attached in height to both horizontal and vertical panel assemblies. The nail holes of the bulkhead clamp allow simple fixing of timbers on site. The site-build bulkhead acts as a spreader. The spindle inside the bulkhead clamp is protected from dirt and concrete residue.

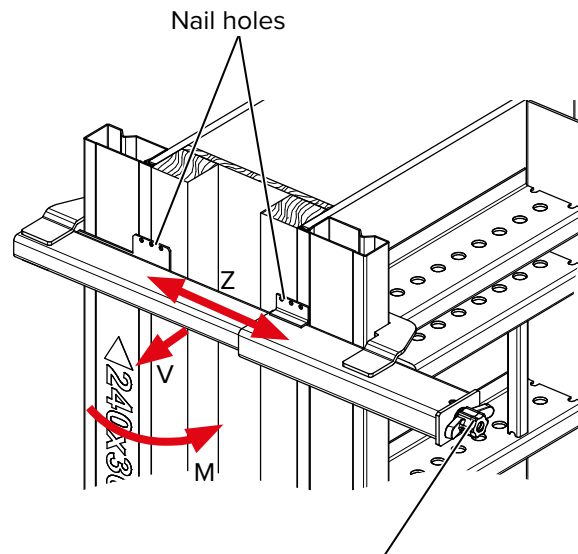

Wing nut, for simple hand or hammer operation, or use with the MANTO ratchet

Load bearing capacity of the bulkhead clamp	
Permitted M	5 kNm
Permitted Z	36 kN
Permitted V	36 kN



WARNING

Warning!

The site build bulkhead must be capable of holding the arising concrete pressure. If necessary add additional bulkhead clamps!

NOTE

Note!

For the correct arrangement of the bulkhead clamps see *chapter Panel connections with increased tensile loads on page 82*.

11.3 With multi bolt and steel waler <42.5 cm

To support the bulkhead form steel walers are attached to the formwork using the PLATINUM 100 multi bolt and the MANTO tie nut. The PLATINUM 100 multi bolt and the waler can be attached to horizontal and vertical panels. It is preferable to attach the multi bolts to the panel at the same elevation as the panel ribs. The waler is then placed over the multi bolts and fixed with the MANTO tie nuts. Tie rod DW 20, edge tie fastener MR ($Z_{perm.} = 10 \text{ kN}$) and tie nut 150 are used as dry tie at the end of the formwork at panels without additional edge ties.

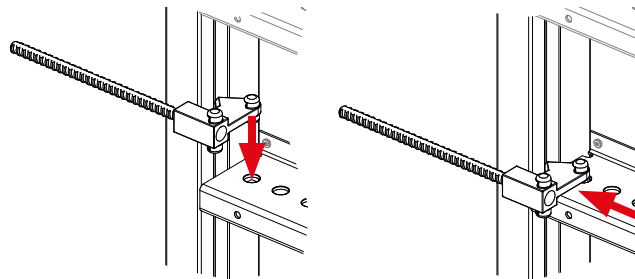
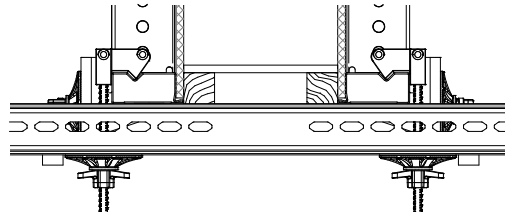

Bulkhead on panels without tie holes in edge profiles

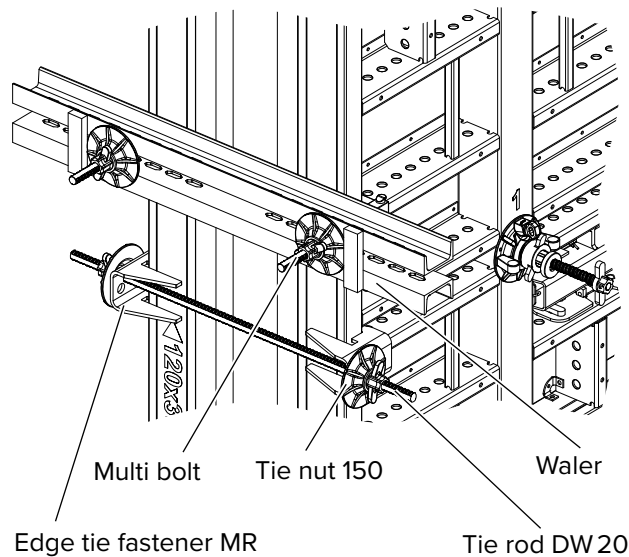

NOTE

Note!

Mount ties and walers at the same elevation like the bulkhead clamps (see page 85).

NOTE

Note!

Follow chapter *Panel connections with increased tensile loads* on page 82!

Installation of multi bolt

The multi bolt is placed diagonally into the hole of the panel rib. By turning the multi bolt into the horizontal position the multi bolt is safely locked to the panel. A PLATINUM 100 tie rod with PLATINUM 100 tie nuts or a tie rod DW 20 with two tie nuts 150 are used as a dry tie at panels with additional edge tie locations allowing to tie directly through the panel frames.

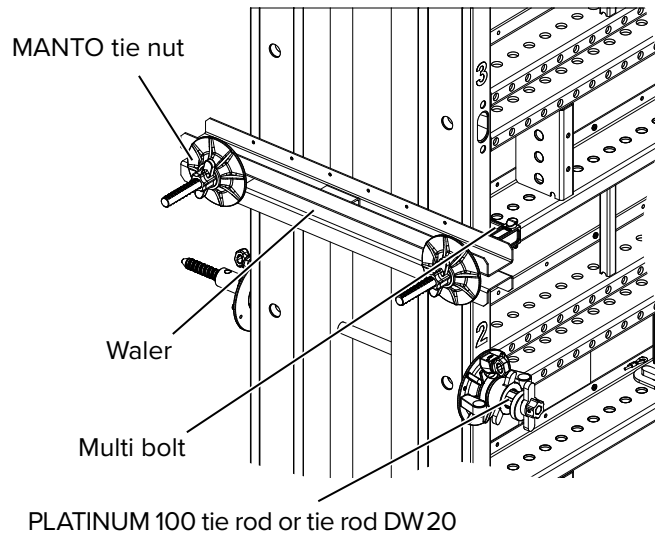
Bulkhead on panels with tying hole in edge profiles

12 Foundation formwork

The FU tightener (prod. code 568357) and the punched steel tape (prod. code 568081) are an alternative to tying through the panels when used for foundations. The permitted load for the FU tightener is 12 kN and for the bulkhead clamp 36 kN.

With these allowable loads and a pouring height of 90 cm, the maximum distance between the ties is 1.75 m.

The bulkhead clamp is used with free and continuous adjustment instead of ties at the edge profiles of the PLATINUM 100 panels.

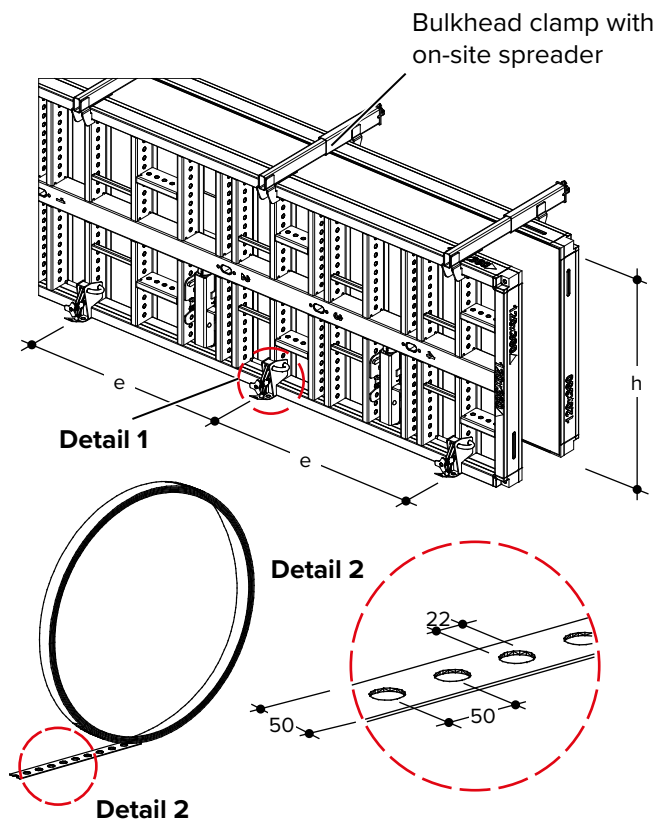

Allowable distance (e) [m] of FU tightener with formwork height (h) [m] as shown in the middle!

h	90	105	120
e	175	130	100

Punched steel tape 25.0 m, Width: 5.0 cm, Thickness: 0.2 cm

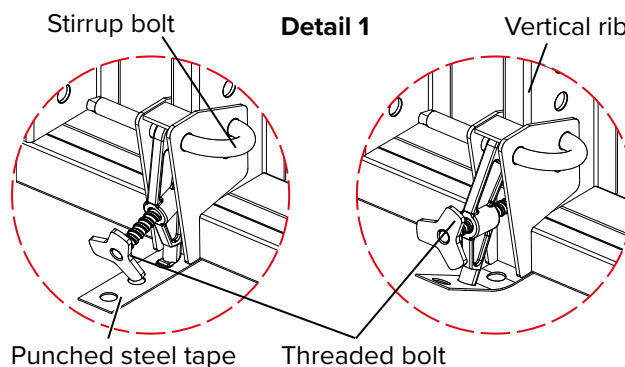

The FU tightener is positioned on the edge profile of the panel and secured to the vertical rib by using the stirrup bolt. Then the punched steel tape that is cut to the correct length must be hooked to the FU tightener. The punched steel tape is tightened by turning the threaded bolt.

Typical corners with lying panels

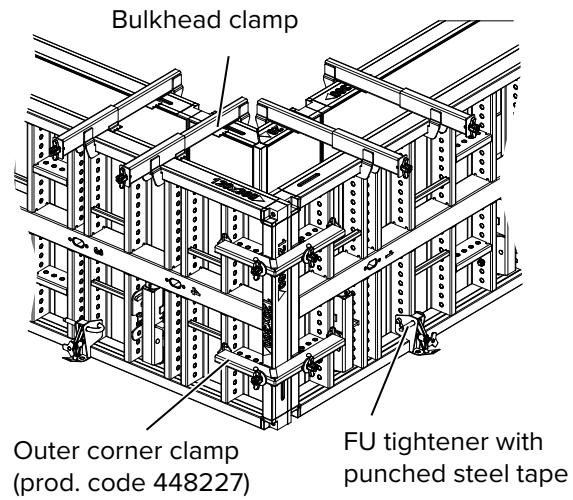

13 Anchors

13.1 Panel Anchor Bracket

The Panel Anchor Bracket (code:605999) can be attached to PLATINUM 100 panels as shown below to secure the panels against horizontal loads and uplift.

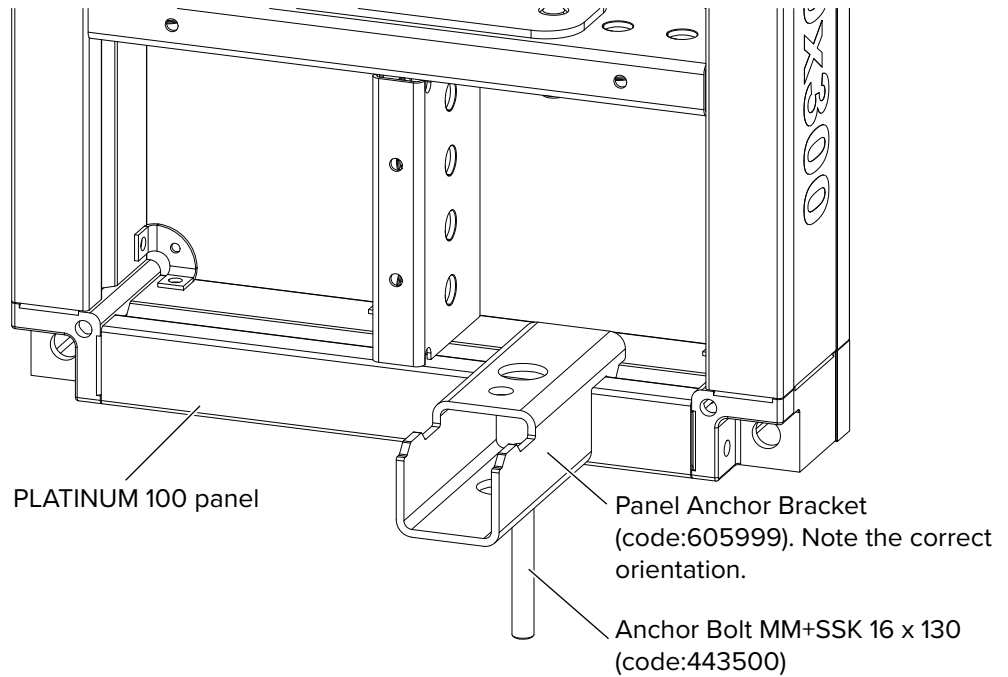

WARNING

Risk of injury from falling panels!

The Customer is responsible for verifying that the existing structure can take the extra imposed loads.



For more information regarding the Anchor Bolt MM+SSK 16 x 130 (code:443500) see page 98. Data sheets are also available upon request.

Installation:

- Step 1** Place the Panel Anchor Bracket (code:605999) at the edge profile of the PLATINUM 100 panel at the location specified by the supplied scheme.
- Step 2** Pass a $\varnothing 14$ drill bit through the $\varnothing 18$ hole of the Panel Anchor Bracket (code:605999) and mark where the hole should be drilled. Remove the Panel Anchor Bracket.
- Step 3** Use a $\varnothing 14$ drill bit to drill a 134 mm hole in the existing structure.
- Step 4** Remove dust from the drilled hole.
- Step 5** Place the Panel Anchor Bracket (code:605999) at the edge profile again, insert the Anchor Bolt through the $\varnothing 36$ hole and screw tight using a 24 mm spanner with an extension.

Step 6 Ensure that the Panel Anchor Bracket (code:605999) is securely bolted.

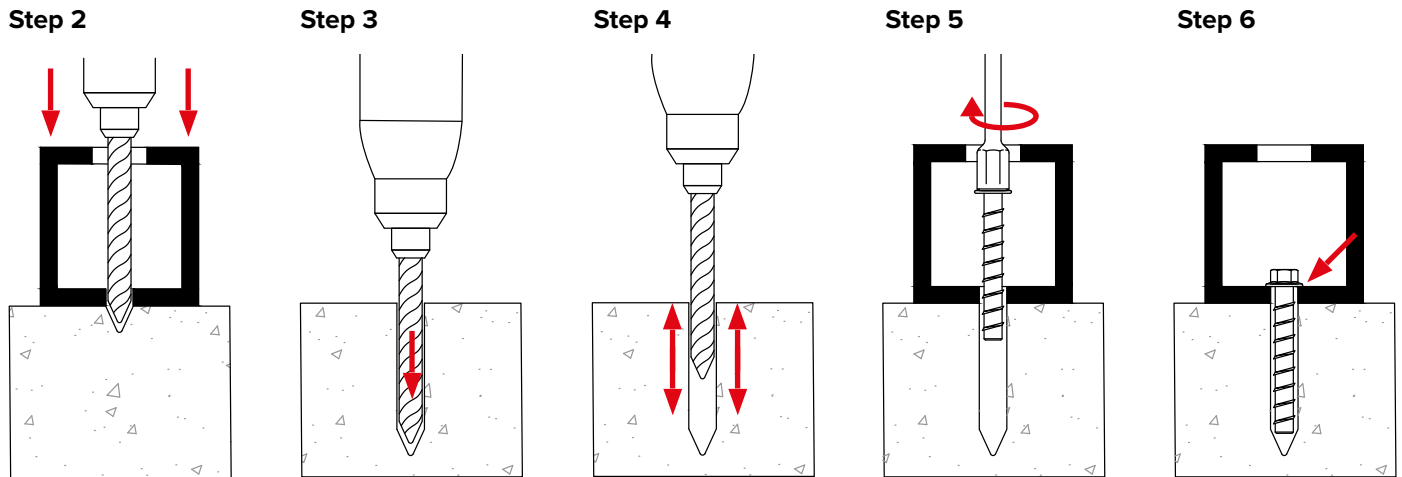

Spacing

The spacing of the Panel Anchor Bracket (code:605999) will depend on several factors.

13.2 Anchor Bolt MM+SSk 16 x 130

The Anchor Bolt MM+SSK 16 x 130 (code:443500) is used to temporarily secure the components to the existing structure. The bolt can be tightened using a 24 mm spanner.

Bottom plate of the Panel Anchor Bracket (code:605999).

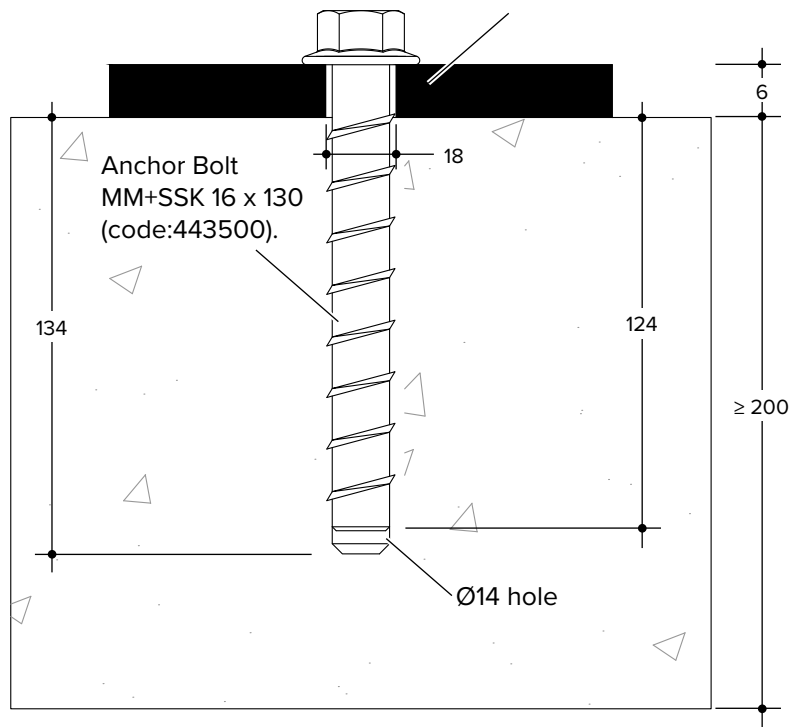

WARNING

Risk of damage and / or injury!

The Customer is responsible for verifying that the concrete strength of the existing structure is in accordance with the specifications shown in page 99.

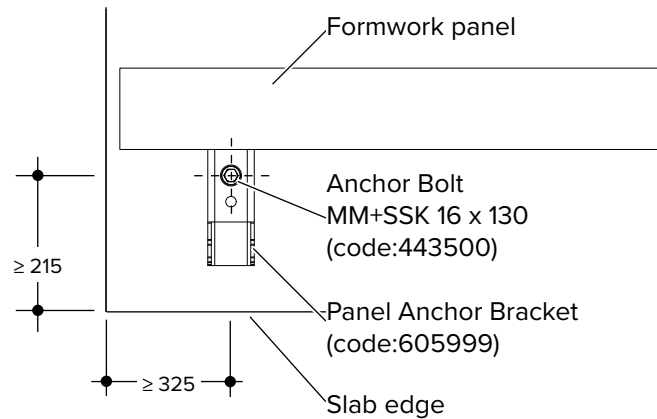

Anchor Bolt MM+SSK 16 x 130 (code:443500)		
Technical data		
Anchor length	L	130 mm
Fixing thickness	t _{fix}	15 mm
Anchoring depth	H _{nom} [L - t _{fix}]	115 mm
Depth of drilled hole	H ₁	125 mm
Drill [Ø]	d ₀	14 mm
Drill bit cutting [Ø]	d _{cut}	14.5 mm
Installation torque	T _{inst}	N/A
Spanner size	SW	24 mm
Minimum spacing	s	≥ 645 mm
Minimum edge distance	c	215 / 325 mm
Minimum concrete thickness	d	≥ 200 mm
Hole in part to be fixed	d _f	17–23 mm

Re-using anchor bolts:

When re-using anchor bolts check the bolt beforehand with the Checking Gauge (code:443501).

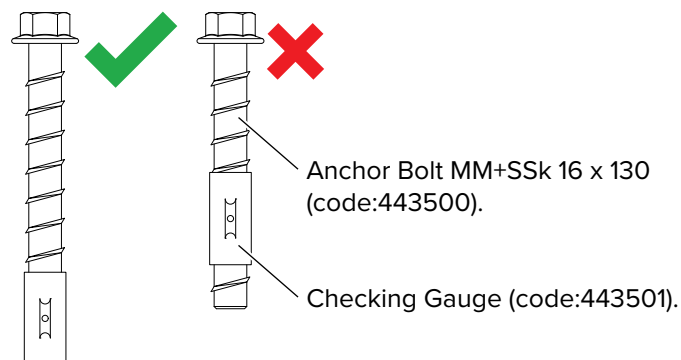

WARNING

Risk of damage and / or injury!

Do not use anchor bolts with visible damage, e.g. corrosion.
Damaged bolts must be disposed of.

WARNING

Risk of damage and / or injury!

If a hole is drilled incorrectly, a new hole must be drilled at a distance equal to at least twice the depth of the incorrectly drilled hole.
Anchors can be re-used but the same hole must not be used a second time.

13.3 Safe Working Loads

The following tables show the Safe Working Loads for the different applications of the Panel Anchor Bracket (code:605999) with the Anchor Bolt MM+SSK 16 x 130 (code:443500). Intermediate values can be found by interpolation.

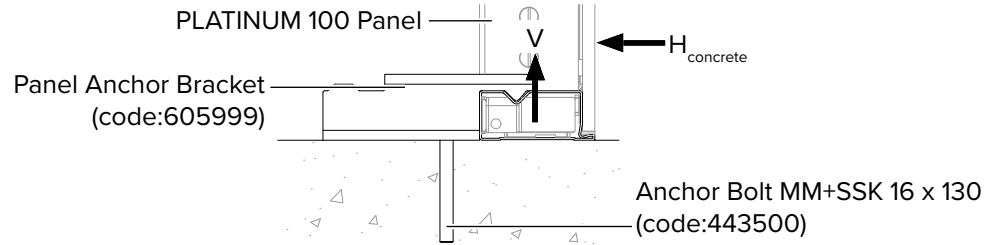

Panel Anchor Bracket (code:605999) + Anchor Bolt MM+SSK 16 x 130 (code:443500)				
with PLATINUM 100 panels				
Concrete pressure - Safe Working Loads				
H _{concrete} [kN]	Concrete strength			
	25 N/mm ²	20 N/mm ²	15 N/mm ²	10 N/mm ²
	V [kN] panel uplift			
0.00	10.58	9.46	8.18	6.68
2.50	10.20	9.07	7.77	6.25
5.00	9.65	8.48	7.14	5.53
7.50	8.91	7.68	6.24	4.46
10.00	7.95	6.62	5.01	2.83
12.50	6.73	5.22	3.24	0.00
15.00	5.14	3.25	0.00	
17.50	2.88	0.00		
19.50	0.00			

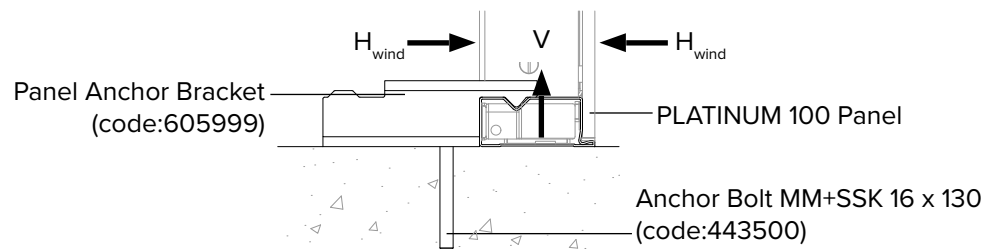

Panel Anchor Bracket (code:605999) + Anchor Bolt MM+SSK 16 x 130 (code:443500)				
with PLATINUM 100 panels				
Wind load - Safe Working Loads				
H _{wind} [kN]	Concrete strength			
	25 N/mm ²	20 N/mm ²	15 N/mm ²	10 N/mm ²
	V [kN] panel uplift			
0.00	10.58	9.46	8.18	6.68
2.50	8.00	6.87	5.57	4.05
5.00	5.25	4.09	2.74	1.14
7.50	2.31	1.09		
9.50	0.00			

14 Panel bracing

Additional parts

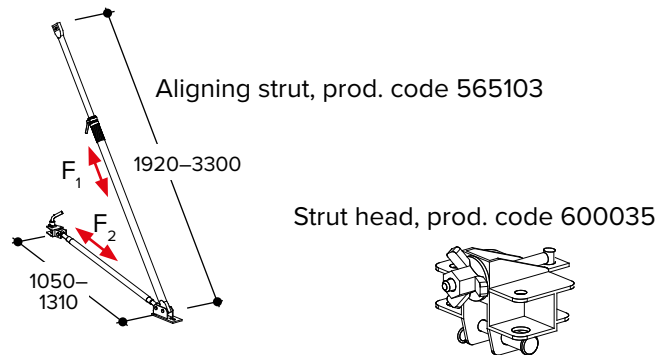

14.1 Bracing up to 390 cm form height

For formwork heights up to 390 cm, the aligning strut is used in combination with the strut head. The strut head is connected to one of the horizontal or vertical ribs of the PLATINUM 100 panel. The first panel is always braced with two aligning struts. The following panels must be braced according to the effective loads.

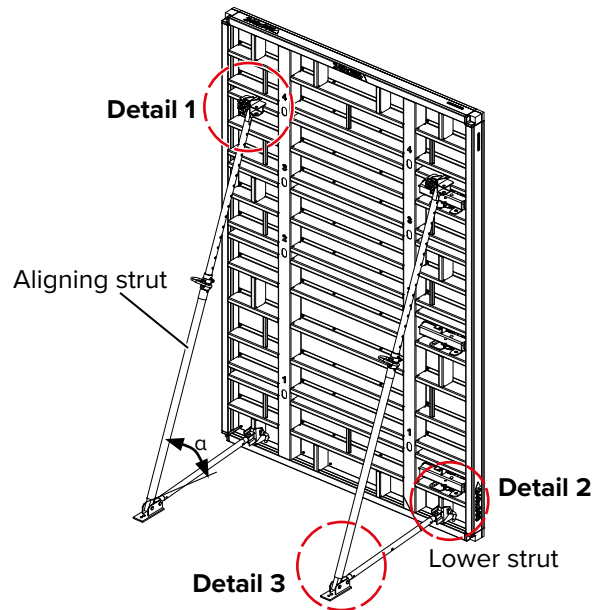

F_{\max} Strut head: 10.00 kN

F_1 extension length min. = 1.92 m–3.15 m: 10.00 kN

F_1 extension length = 3.30 m: 8.25 kN

$F_{2 \max}$ Lower strut: 7.50 kN

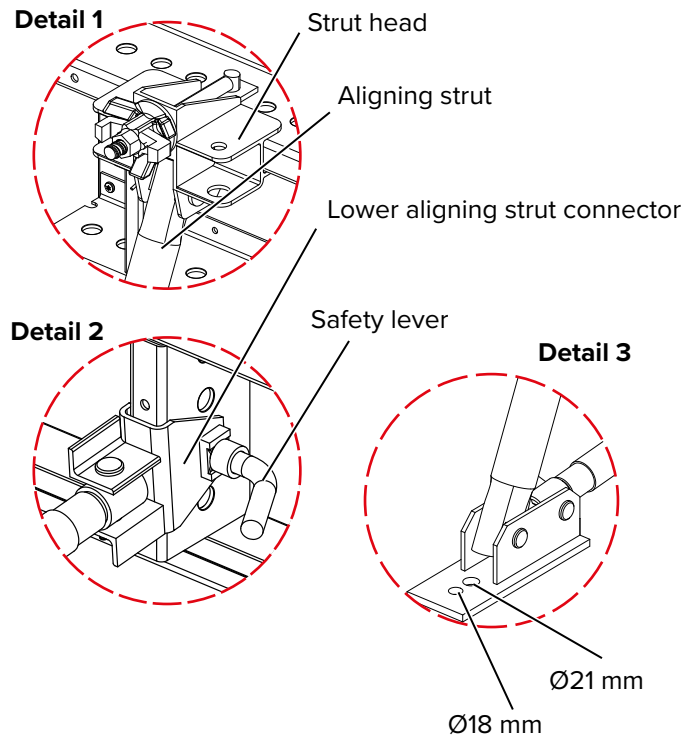

14.2 Bracing higher than 390 cm form height

At formwork applications higher than 390 cm that are connected with PLATINUM 100 MANTO extension bars, the triangular struts are fixed to the extension bars. Additional single alignment struts are required. The alignment struts are fixed with the adapter for aligning struts and the strut head. All alignment struts are telescopic and have a low weight. They are used for adjustment. The encapsulated thread allows fine-tuning.

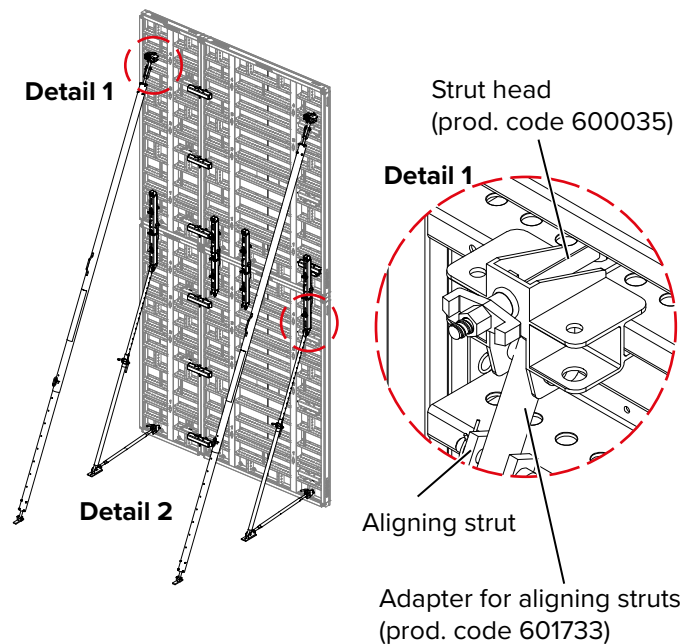

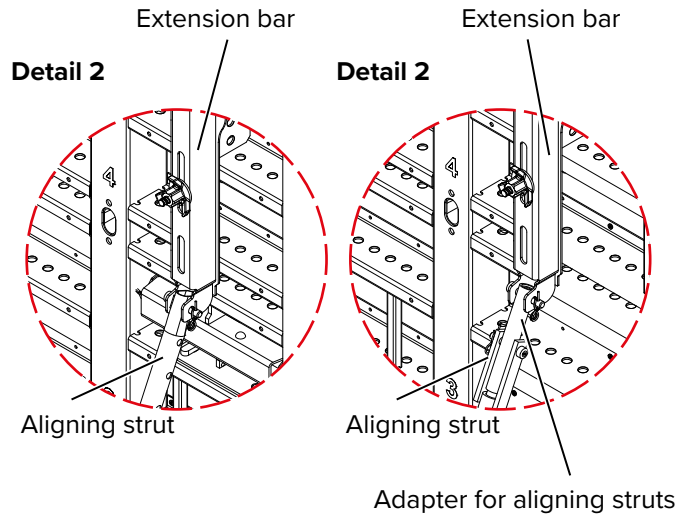

Alignment strut K440 extension length 3.25 - 4.40 m

Alignment strut K600 extension length 4.80 - 6.00 m

Alignment strut K760 extension length 5.30 - 7.60 m

Alignment strut Super 10 extension length 7.05 - 10.25 m



WARNING

Warning!

The maximum permitted strut load of the used struts respectively the maximum load bearing capacity of the connection parts must not be exceeded!

Permitted loads		K440	K600	K760		Super 10
extension length [m]		3.35–4.65	6.20–7.90	5.40–6.00	6.00–7.80	7.60–10.50
Connection	directly to panel	10 kN	10 kN	10 kN	10 kN	10 kN
	to extension bar	18 kN–10 kN*	17 kN–11 kN*	18 kN	18 kN–12 kN*	18 kN

Intermediate values can be interpolated in a linear way.

* Load bearing capacity depending on extension length

Connection directly to panel: alignment strut → adapter for aligning strut → strut head → panel

Connection to extension bar: alignment strut → adapter for aligning strut → extension bar

15 Platform and access systems

15.1 PLATINUM 100 platform and access system

The PLATINUM 100 platform and access system is fully compatible to the wall formwork systems PLATINUM 100 and MANTO of HÜNNEBECK.

The PLATINUM 100 platform and access system permits safe access and allows safe execution of all work at the wall formwork (e.g. tying and connection) and it is used as a concreting platform at the highest level of the formwork. The PLATINUM 100 platforms are designed to meet the requirements of load class 2 according to DIN EN 12811 (1.5 kN/m²). They are equipped with integrated backrailings as well as side railings, advanced railings and self-closing passages. Adjustments, counter posts, ladders, useful accessories and the compatibility with the PROTECTO guard railing system extend the platform system and allow an adaption to each formwork situation. This allows the execution of work at the formwork from a safe position.

For more information on the PLATINUM 100 platform and access system see the separate user guide.

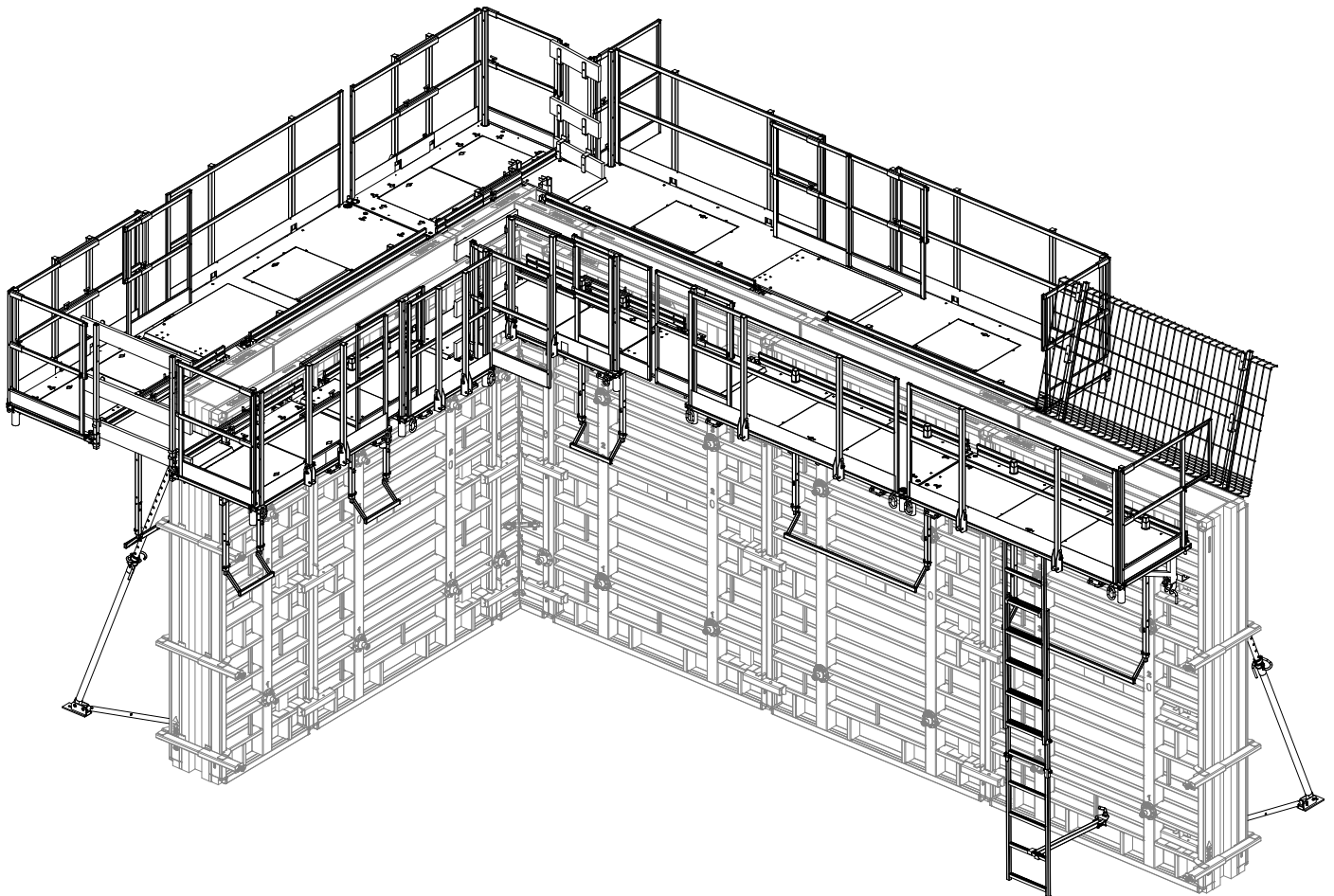

15.2 PLATINUM 100 platform step

The PLATINUM 100 platform step is used as climbing aid at the PLATINUM formwork to reach tie locations, connection points of aligning struts and connection parts. The platform step can be hooked to the 3 lowest cross rib profiles of the PLATINUM formwork. The platform step can be used at vertically arranged formwork panels.



WARNING

Warning!

The max. permitted fall height according to ASR A2.1 is 1.00 m!

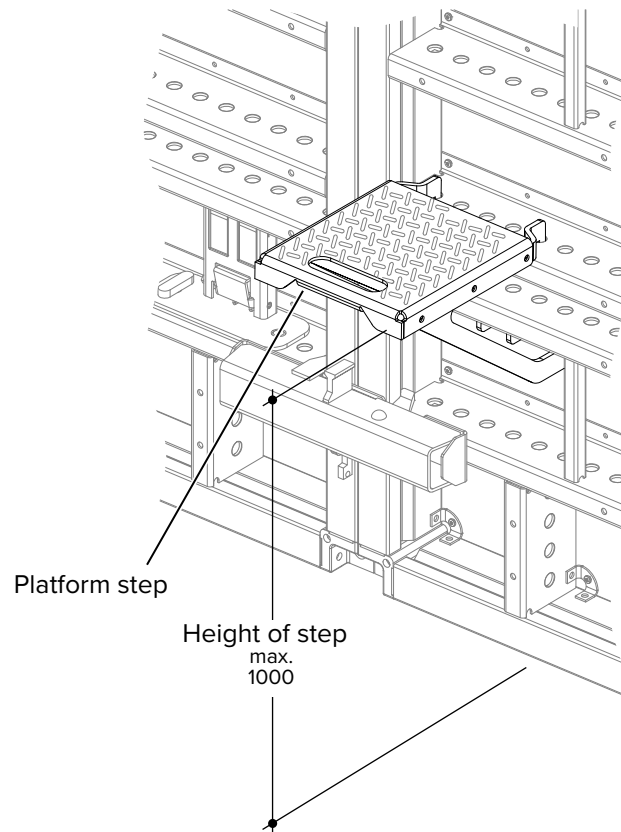

To hook the step to the profiles insert the pins of the platform step into the holes of a rib of the PLATINUM panel.

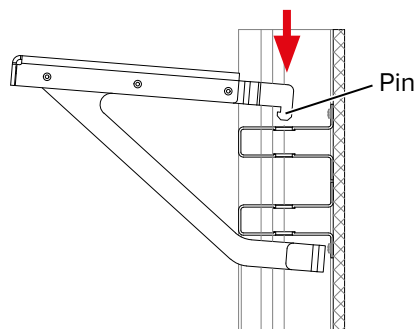

Then swivel down the step. The grooves in the pin grip into the rib profile and secure the step against unintended falling out.

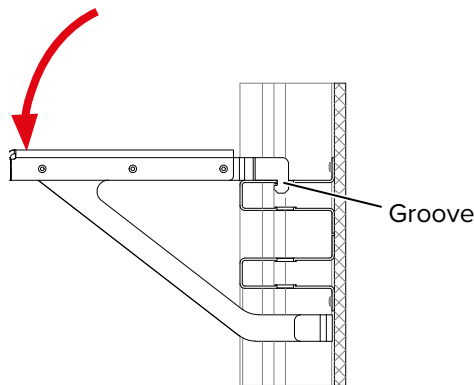

15.3 Walkway bracket

The walkway bracket is designed for load class 2 loads according to DIN EN 12811-1:2004-03 and DIN 4420-1: 2004-03.

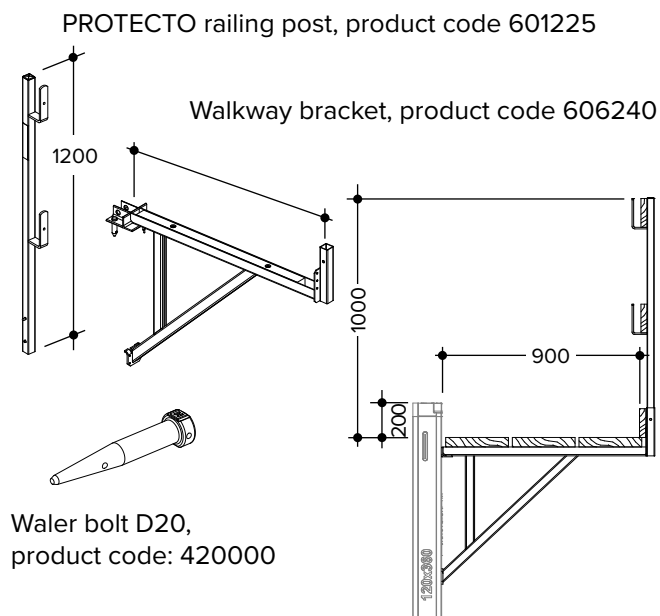

WARNING

Warning!

The permitted distance between the walkway brackets is 2.50 m at a permitted working load of 1.5 kN/m². The decking must be adequately secured against uplift! When using timber railings at wind speeds between 110 km/h (wind load 0.6 kN/m²) and 125 km/h (wind load 0.8 kN/m²) the permitted spacing between the brackets is 2.00 m. Deviations to all national and local regulations must be followed!

Attaching the walkway bracket to a vertical panel

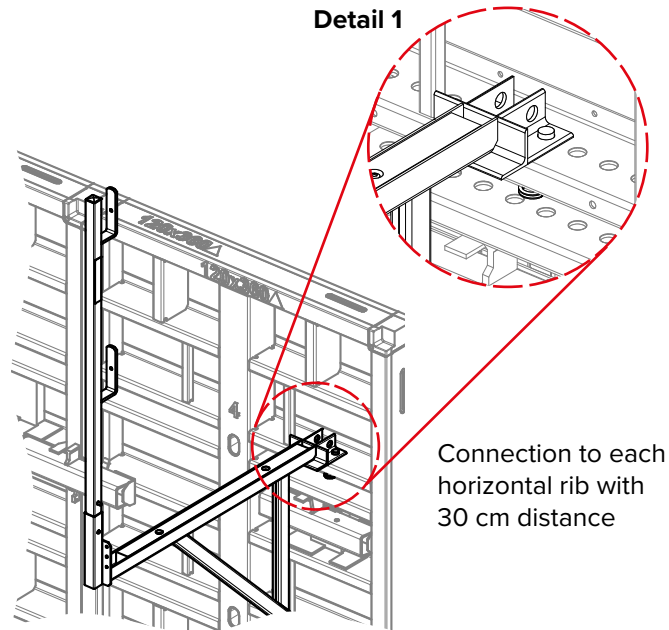

The walkway bracket and the inserted post make up the platform assembly. Simply hang the brackets, using the pegs, into the holes in the horizontal ribs of the panels. Then secure the bracket with the attached spring pin.

Attaching the walkway bracket to a horizontal panel

The walkway bracket is attached to a horizontal panel with the waler bolt D20 (prod. code 420000) through the (now vertical) horizontal ribs.

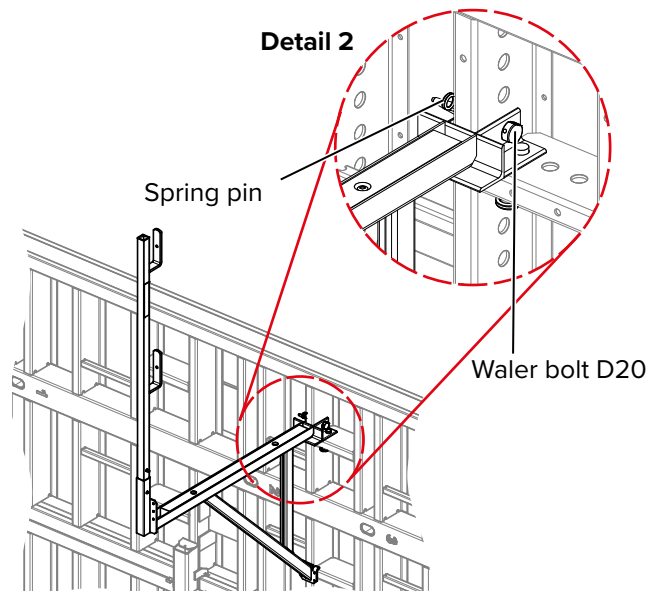

15.4 Pouring platform

The pouring platform 240 is used as the top working platform with the PLATINUM 100 formwork.

Permitted load:

2.0 kN/m² as single platform

1.5 kN/m² with adjustment

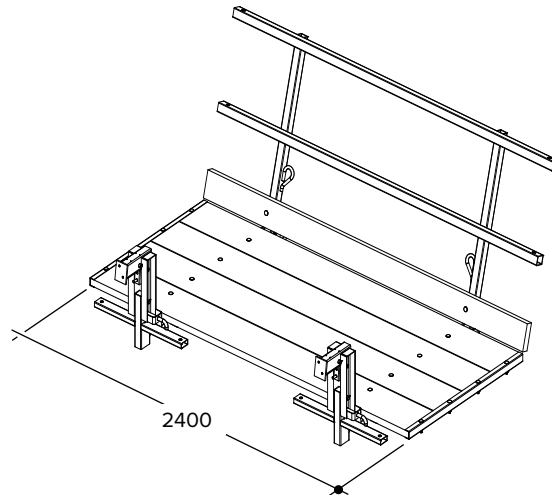

WARNING

Warning!

When using the pouring platform at lying extended panels, ties are always necessary in the uppermost tie position!

Stacking heights of the pouring platforms 240

The pouring platforms 240 are delivered as folded units.

The stacking height is 40 cm for the lower platform and 20 cm for all further units.

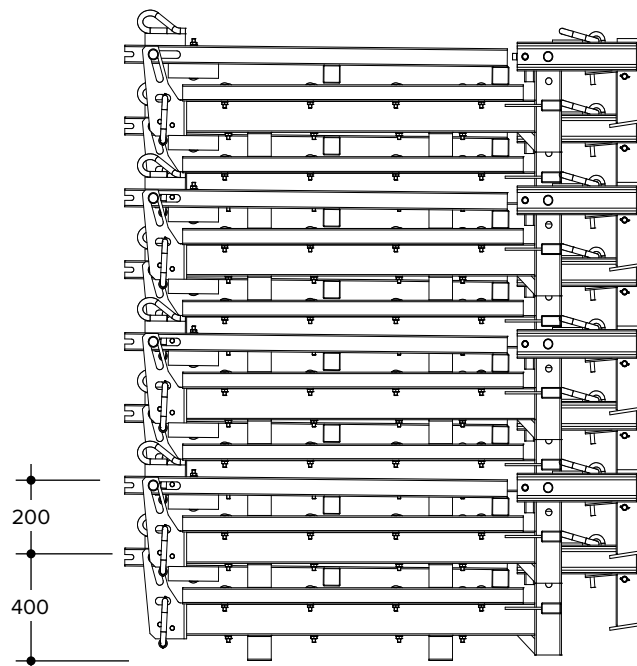

WARNING

Warning!

The maximum stacking height is eight platforms!

Attaching the pouring platform 240 to a crane

Option 1

With the platform folded, the crane suspension has to be attached to the adjustment eye hook (1). The eye hook is part of the base construction for the railing post of the pouring platform 240.

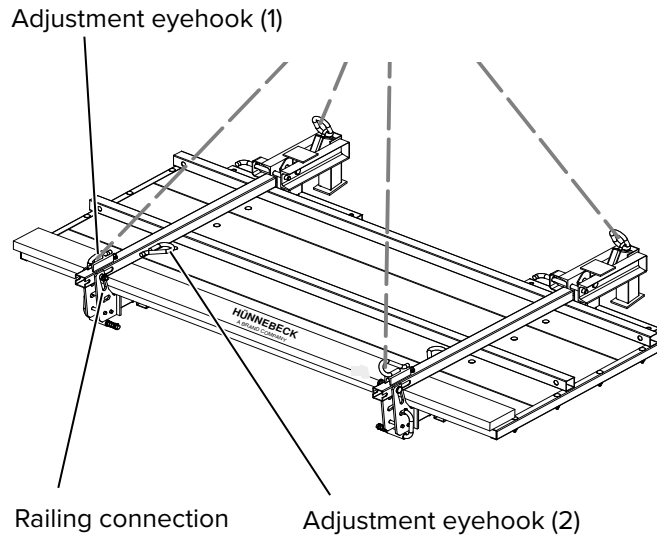

15.4.1 Assembling the Pouring platform 240

First pull out the bolt D 16 ① Lift the railing ② to the vertical position and then lock it in the desired position ③.

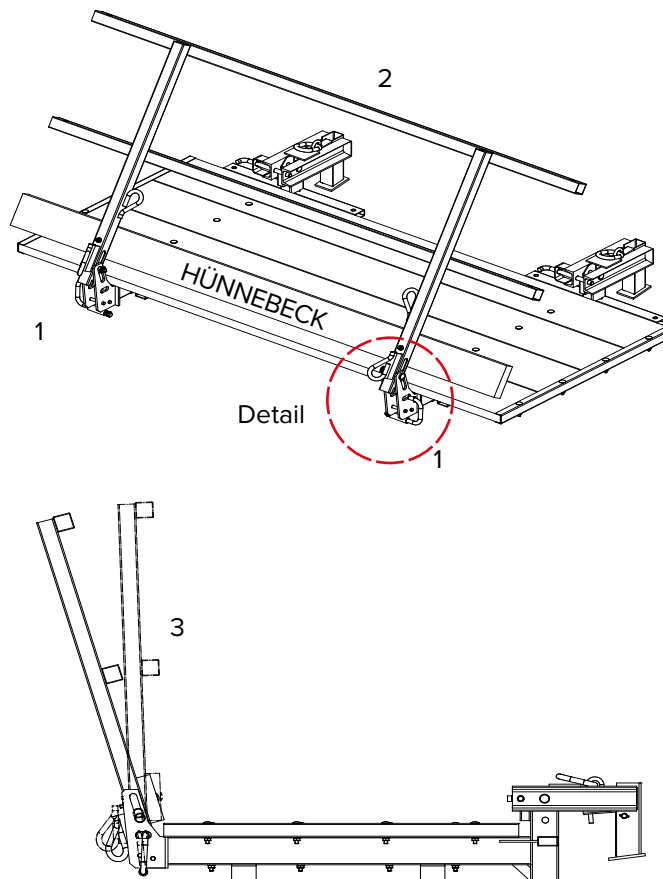

Then the bolt D 16 must be inserted again to lock the railing ④.
The railing can be used in vertical as well as in inclined position.

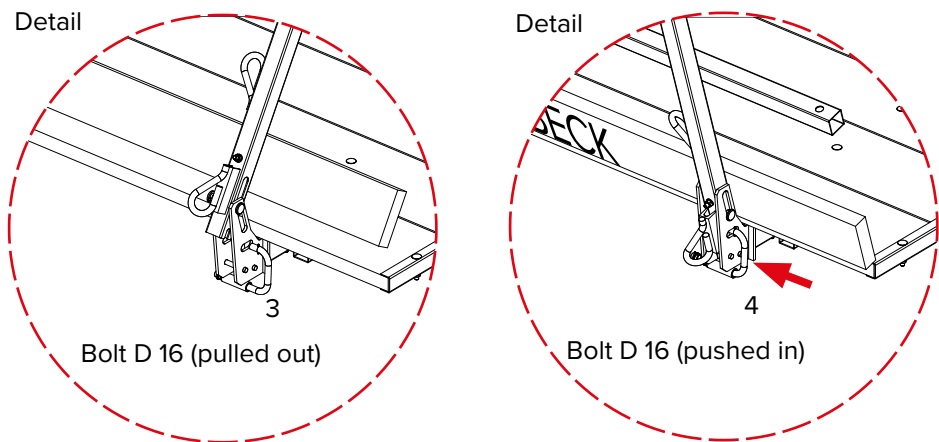

To erect the support bracket, the bolt B 18 must be pulled out, and the support bracket must be swiveled into a vertical position.

Transport or storing position

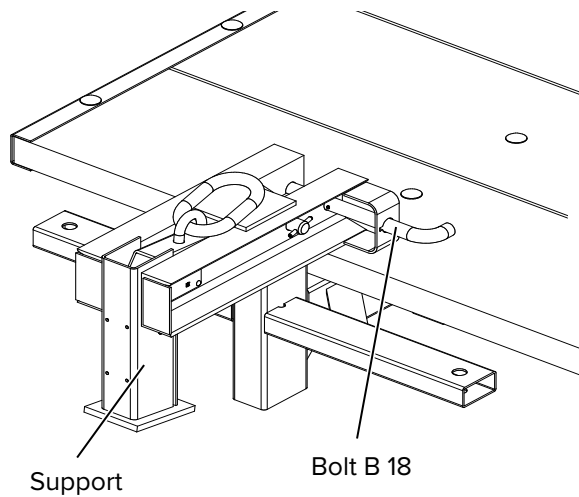

When in a vertical position, the support bracket must be locked with the bolt B 18.

Working position

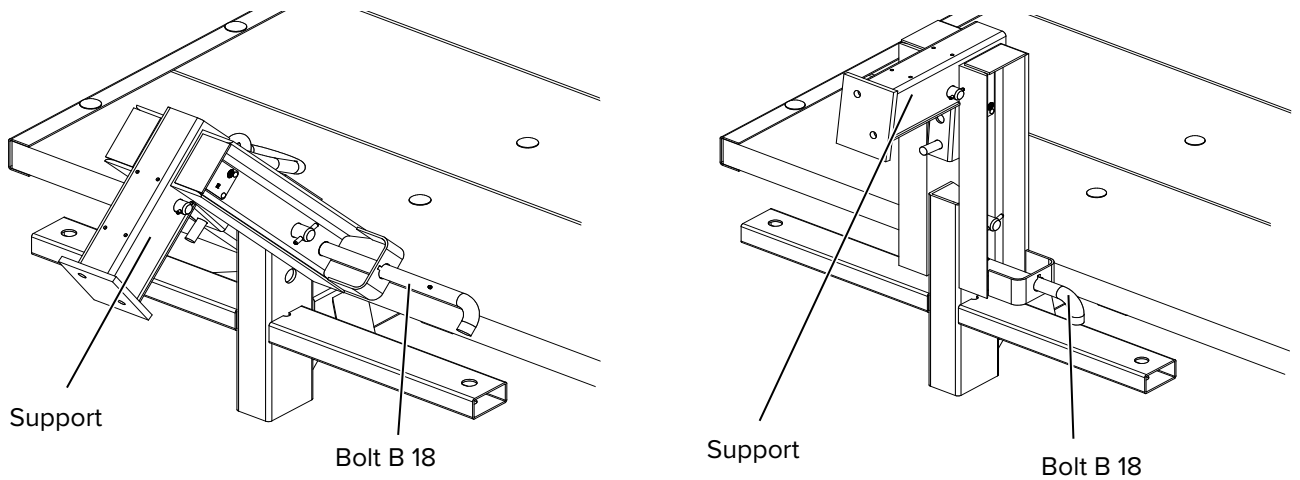

Attaching the pouring platform 240 to the crane

Option 2

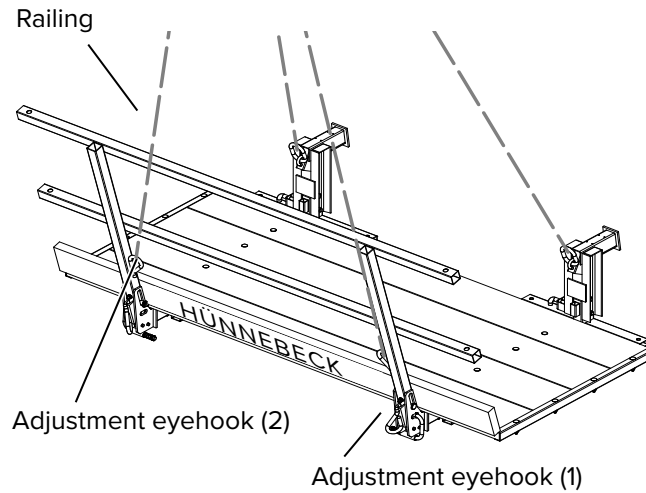

WARNING

Warning!

The platform must not be transported together with the PLATINUM 100 panel!



VISUAL CHECK

When unfolded, make sure that the crane is attached to the adjustment eyehook (2).

Attaching the pouring platform 240 to the formwork

The pouring platform is equipped with a self-securing suspension device that automatically works after releasing the crane ropes.

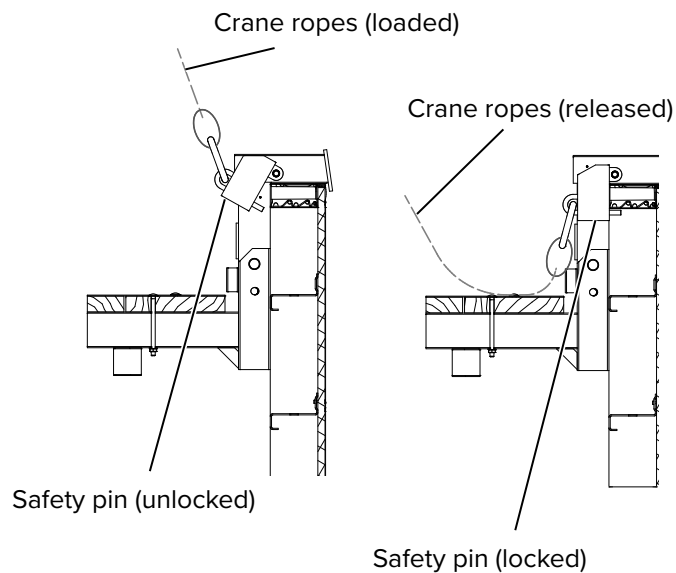

VISUAL CHECK

The safety pin must be locked correctly.

Length adjustment and transverse railing

Length adjustments from 20–100 cm are achieved with on-site planks, an on-site toe board and two or four guard railing extensions (prod. code 498218). The on-site planks must have an overlap of 45 cm at both ends and must be properly secured to prevent them from sliding (e.g. nails). The end of the platform is secured with the transverse railing.

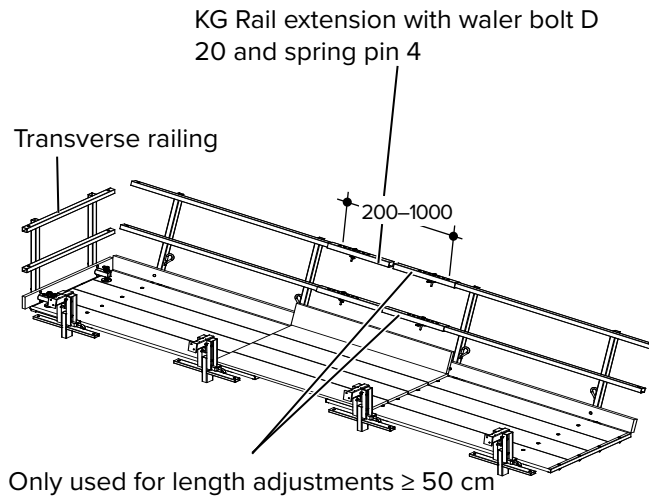

16 Panel transport



VISUAL CHECK

Before transporting the panels make sure that the aligning wedge clamps are stored safely in the panel.

16.1 With the PLATINUM 100 transport hook

The PLATINUM 100 transport hook has a maximum load capacity of 10 kN (1,000 kg). The permitted applications are described below.

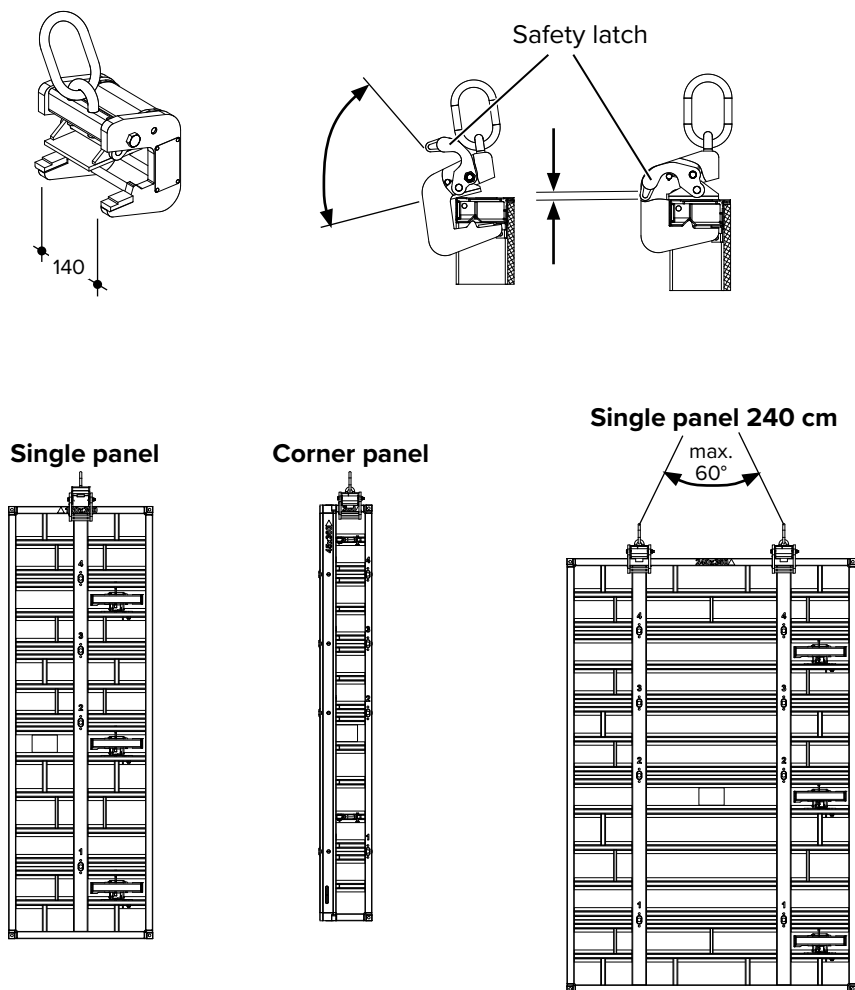

WARNING

Warning!

Follow the separate operating instructions of the PLATINUM 100 transport hook! Ensure that the safety latch of the PLATINUM 100 transport hook is correctly closed and completely engaged with the frame! The spread angle of the crane sling must not exceed 60°. Follow the operating instructions of the PLATINUM 100 transport hook!

Combined panels must always be lifted with two crane hooks. The maximum area of the combined panels must not be bigger than 25 m². Otherwise the load carrying capacity of the crane hooks is exceeded. When transporting the panels with accessories like struts and platforms attached, the area of the combined panels must be reduced accordingly.

Two panels 240 cm

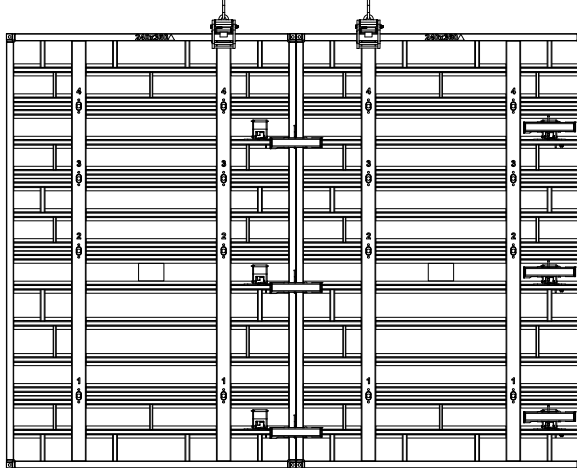

Extension with horizontal panel

Three panels

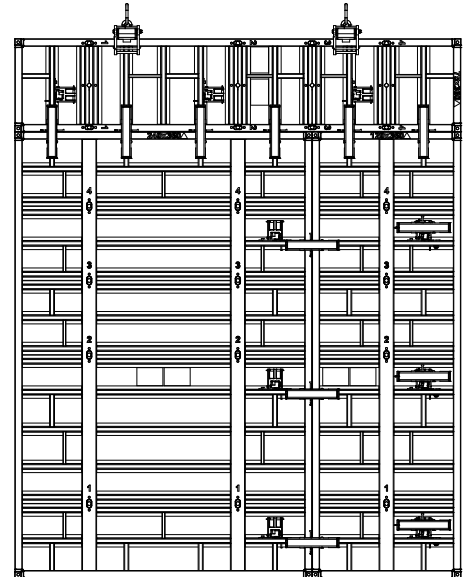
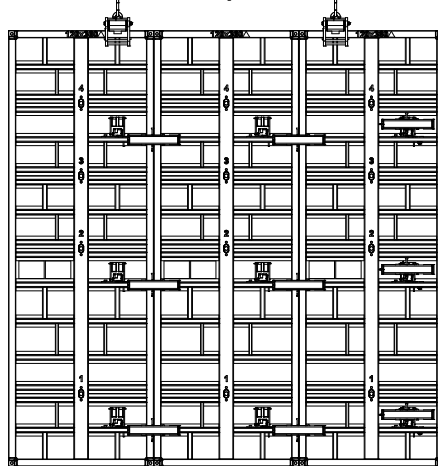

WARNING

Warning!

It is not permitted to exceed the maximum load bearing capacity of the PLATINUM 100 transport hook of 10 kN (1,000 kg)!

16.2 With the PLATINUM 100 transport hook plus

The PLATINUM 100 transport hook plus has a maximum load capacity of 15 kN (1,500 kg). The permitted applications are described below. Completely place the transport hook plus over the edge profile of the panel. With a short stroke at the lifting eye the transport hook plus is locked and the lock indicator (red) is no longer visible. Now the transport hook plus can be attached to the crane. To release the PLATINUM 100 transport hook plus by hand press the green release button at the backside of the hook. As an alternative the transport hook plus can also be released via the distance release from below with e.g. a roof batten.

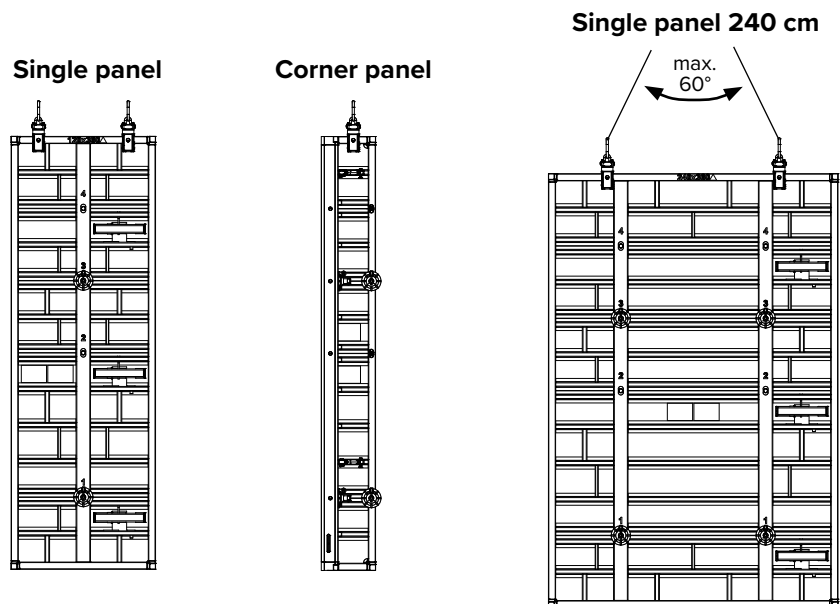
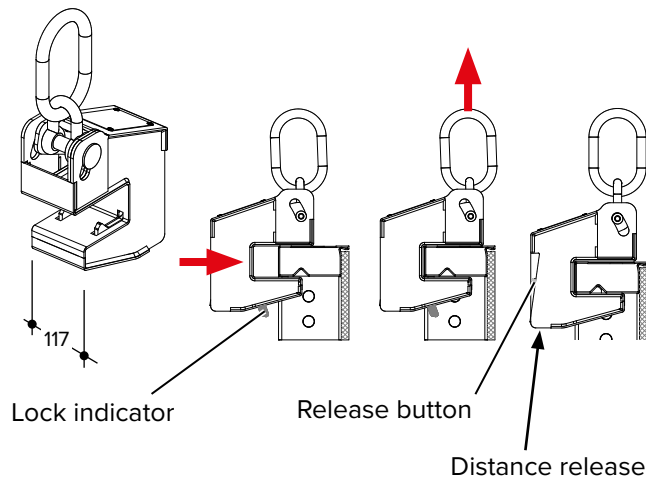

WARNING

Warning!

Ensure that the transport hook plus is completely placed over the edge profile of the formwork. The lock indicator of the PLATINUM 100 transport hook plus must not be visible before lifting with the crane! Otherwise don't lift the load and check the seating of the transport hook plus! The spread angle of the crane slings must not exceed 60°!

Combined panels must always be lifted with two crane hooks. The maximum area of the combined panels must not be bigger than 30 m². Otherwise the load carrying capacity of the crane hooks is exceeded. When transporting the panels with accessories like struts and platforms attached, the area of the combined panels must be reduced accordingly.

Two panels 240 cm

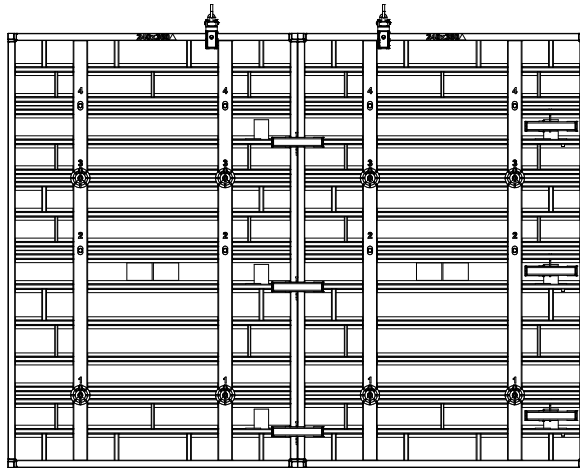

Extension with horizontal panel

Three panels

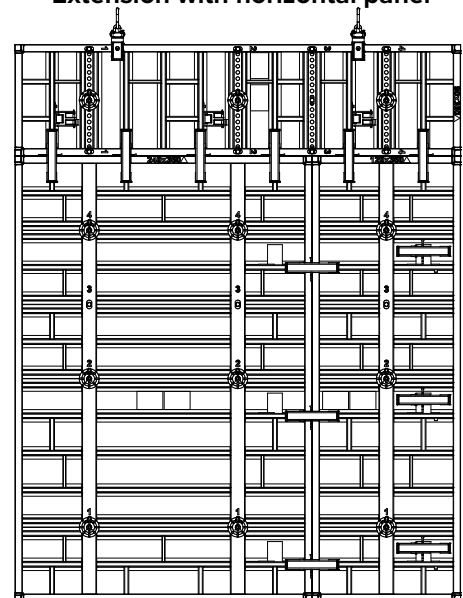
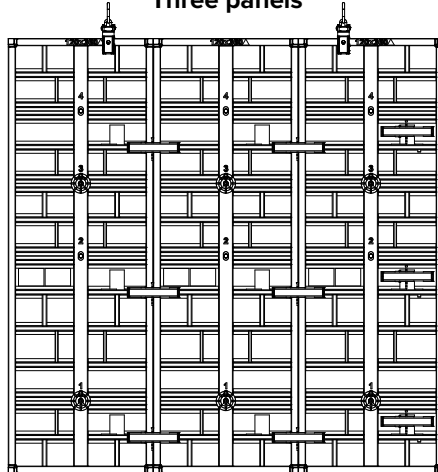

WARNING

Warning!

Follow the separate operating instructions of the PLATINUM 100 transport hook plus!
It is not permitted to exceed the maximum load bearing capacity of the crane hook,
15 kN (1,500) kg!

16.3 Transport of panel bundles

Transport by crane of horizontal panels and panel bundles

The illustrations show the proper and safe slinging of horizontal PLATINUM 100 panels and panel bundles for the transport by crane in warehouses and on job sites.

PLATINUM 100 panel bundles must be secured against unintended sliding by using an additional ratchet strap before attaching to the crane. Suitable are ratchet straps according to DIN EN 12195-2 with a length L1 of ≥ 6.50 m and a permitted tensile load with basket hitches of LC (Load Class) ≥ 5000 daN (prod. code: 605188).

Use the PLATINUM 100 lifting gear for lifting of panel bundles and single panels. It is attached to the corners of the PLATINUM 100 panels.

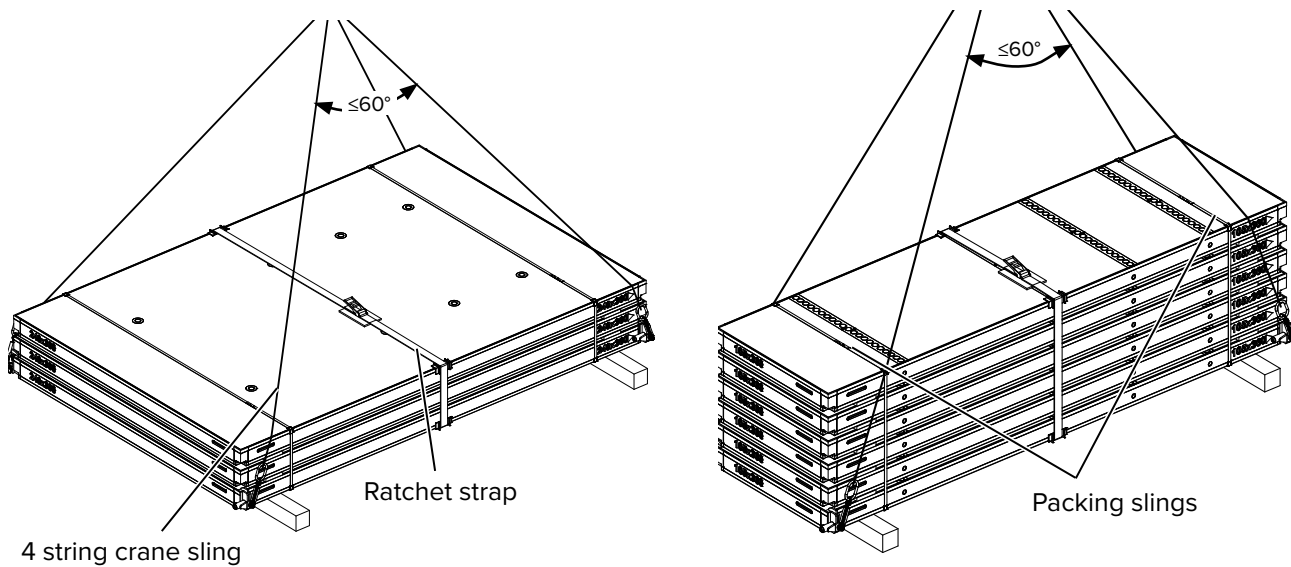

WARNING

Warning!

Follow the separate operating instructions for the PLATINUM 100 lifting gear!

By pulling out and lifting the wedge (1) the locking of the shutter (2) is opened and the pin of the lifting gear can be inserted into the lower hole in the corner of the PLATINUM 100 panel. Swiveling the shutter (3) releases the locking and the wedge can be pushed down and then fixed with a light hammer stroke (4). The red color marking of the wedge is no longer visible.

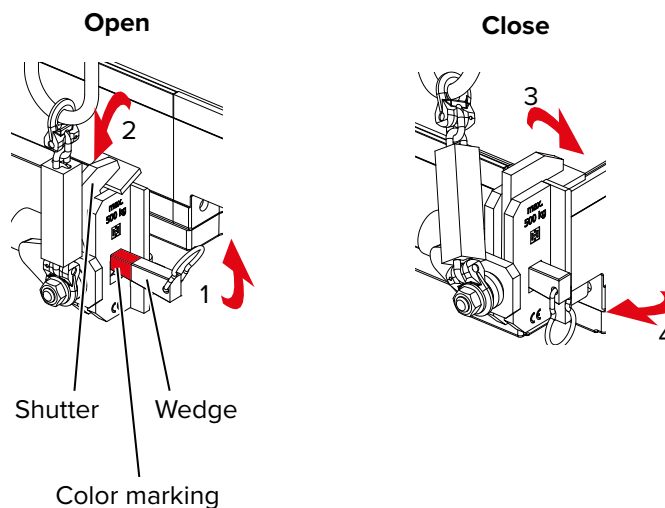

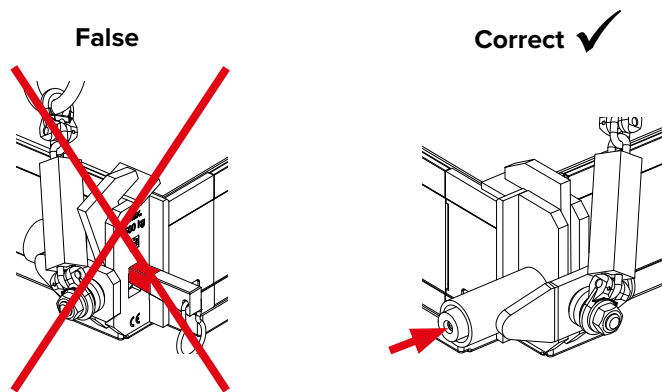

! WARNING	<p>Warning! Shutter not closed and wedge not locked! The shutter is not swiveled over the panel and the color marking of the wedge is still visible. Place lifting gear again, swivel shutter, insert and fix wedge again.</p>
-------------------------	--

NOTE	<p>Note! If the wedge can not be released by pulling the lifting eye place light hammer strokes on the opposite side of the wedge.</p>
-------------	--

! WARNING	<p>Warning! The vertical transport of hanging PLATINUM 100 panels with the lifting gear is not permitted!</p>
-------------------------	---

Applicable standards and technical regulations:

- DIN EN 1492-1 + A1:2008 - Flat woven webbing slings made of man-made fibres for general purpose use
- DIN EN 12195-2 Web lashing made from man-made fibres
- VDI 2700 Blatt 3.1 - Securing of loads
- DGUV Regel 100-500 – Use of work equipment.

Stacking instructions for PLATINUM 100 panels

Panel size [cm]	Dead weight [kg]	Pieces/bundle	Total weight [kg]
240 x 360	590.50	3	1771.50
240 x 300	487.15	3	1461.45
120 x 360	336.62	5	1683.10
120 x 300	276.22	5	1381.10
120 x 120	119.32	7	835.24
VZ 105 x 360	322.73	6	1936.38
VZ 105 x 300	260.01	6	1560.06
VZ 105 x 120	109.97	7	769.79
VZ 105 x 90	88.81	7	621.67
90 x 360	289.83	6	1738.98
90 x 300	233.51	6	1401.06
90 x 120	99.32	7	695.24
90 x 90	62.59	7	438.13
75 x 360	212.17	7	1485.19
75 x 300	172.25	7	1205.75
75 x 120	75.67	7	529.69
75 x 90	53.31	7	373.17
60 x 360	185.32	7	1297.24
60 x 300	150.06	7	1050.42
60 x 120	66.51	7	465.57
60 x 90	47.34	7	331.38
45 x 360	126.55	7	885.85
45 x 300	105.31	7	737.17
45 x 120	45.55	7	318.85
45 x 90	38.28	7	267.96
240 x 120	210.87	7	1476.09
240 x 90	147.71	7	1033.97
240 x 60	108.21	7	757.47
Maximum 7 panels/bundle			

16.4 Turning of single PLATINUM 100 panels

With two PLATINUM 100 lifting gears attached to the front side and a 2-string lifting gear a single PLATINUM 100 panel can be turned. The panel must be secured at the nadir against uncontrolled movement.

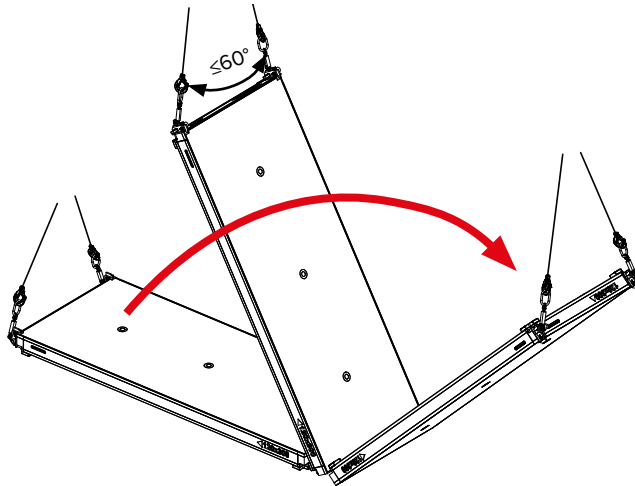

WARNING

Warning!

It is not permitted to attach the lifting gear at the longitudinal sides of the panel.



WARNING

Warning!

It is also not permitted to turn and transport panel assemblies.

17 SCC concrete pump port

Using the SCC panel connection PLATINUM DN 125 it is possible to fill closed formwork with SCC (self-compacting concrete). The SCC panel connection PLATINUM DN 125 can be mounted to 90 cm wide panels and MP panels.

Detail: hole in ECOPLY form sheet

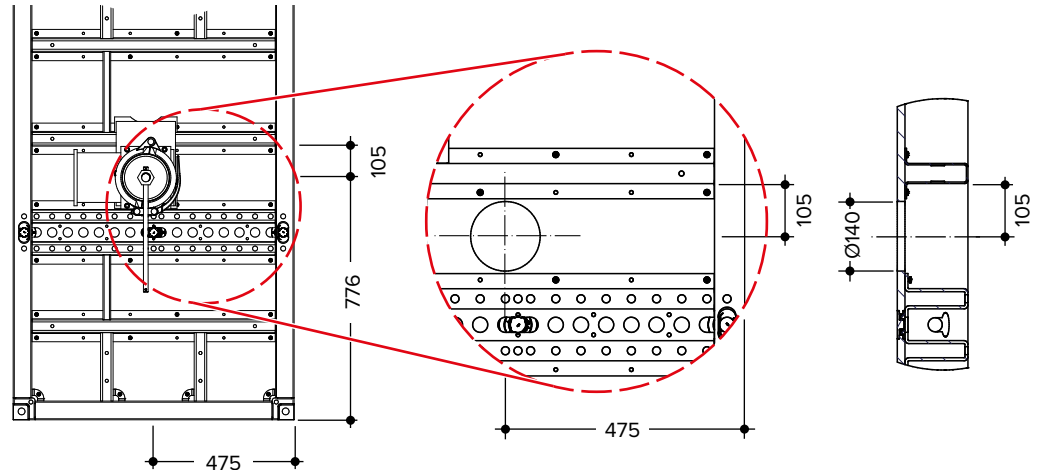

A hole with a diameter of Ø14 cm is drilled at the correct point through the ECOPLY form sheet, and the SCC panel connection PLATINUM DN 125 is bolted to the panel frame.

The SCC panel connection PLATINUM DN 125 is designed to be bolted directly onto the PLATINUM 100 panel. The holes in the SCC panel connection PLATINUM DN 125 are matching the holes of the PLATINUM 100 panel ribs.

Two steel walers are attached on each side of the SCC panel connection PLATINUM DN 125 for safe and equal load distribution.

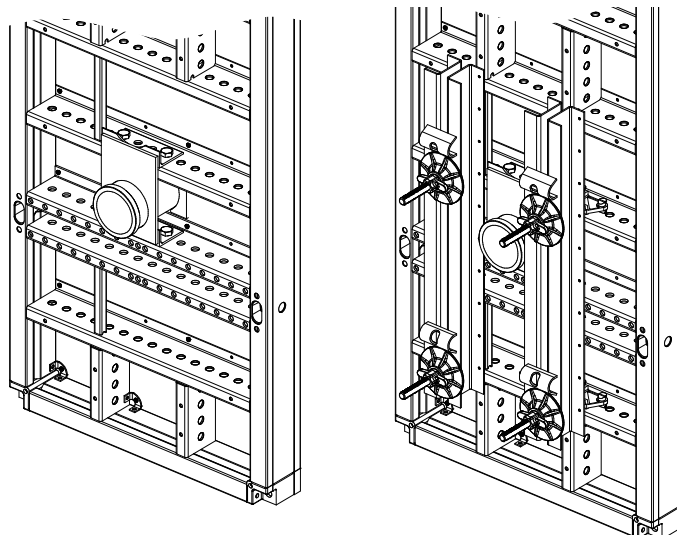

Multipurpose waler 100, prod. code 450764
Multi bolt, MANTO tie nut



WARNING

Warning!

The number and position of the SCC panel connections must be planned with customer input to ensure that the permitted concrete pressure is not exceeded and the desired, even results are achieved!

Due to the high dynamic loads on the formwork during pumping, it is important to place ties at the edges of the panel where the SCC panel connection PLATINUM DN 125 is connected to and its opposing panel as shown.

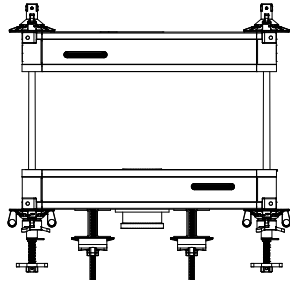
**WARNING****Warning!**

Concrete pressure must not exceed 100 kN/m²!

The SCC closing unit DN 125 cpl. consists of an SCC shutter DN 125, which is connected along with the SCC hose clamp DN 125 and the SCC seal ring DN 125 to the SCC panel connection PLATINUM DN 125.

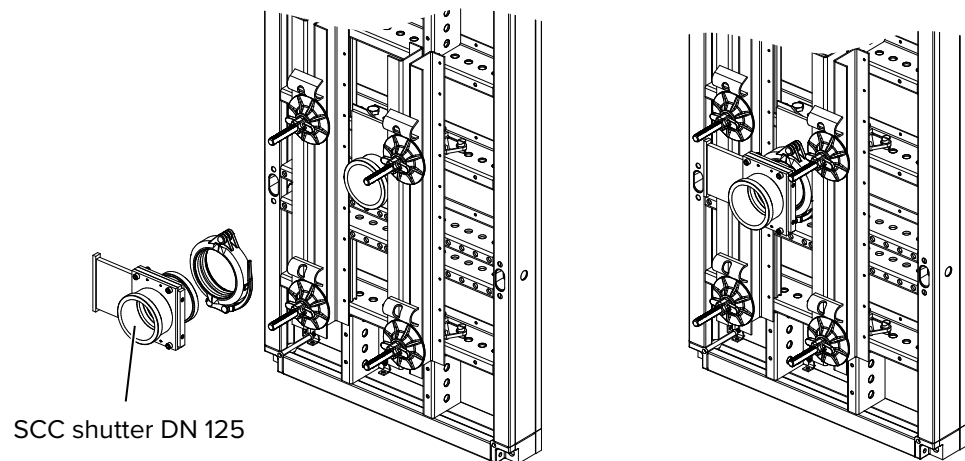

SCC shutter DN 125

17.4.1 Connecting the hose of the concrete pump

An additional SCC hose shutter can also be attached to the concrete hose to prevent the loss of fresh concrete when switching in-between concrete pump ports. This hose shutter is connected to the pump hose using the SCC hose clamp DN 125 and the SCC seal ring DN 125.

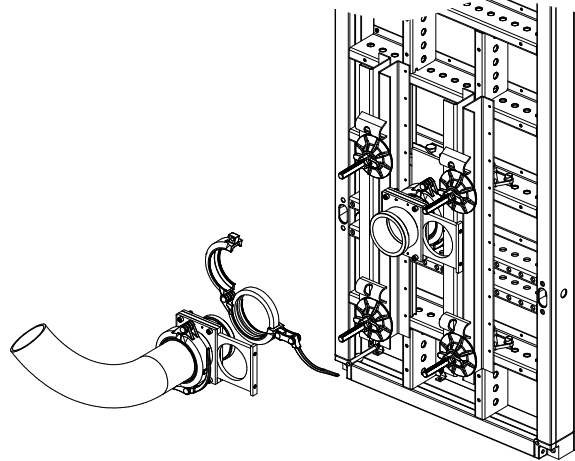

When the SCC shutter of the pump port and the hose shutter are opened, it is possible to start pumping the concrete into the formwork.

Advantage:

When the pumping is finished, it is possible to close the valves and remove the concrete hose without the concrete running out of the formwork.

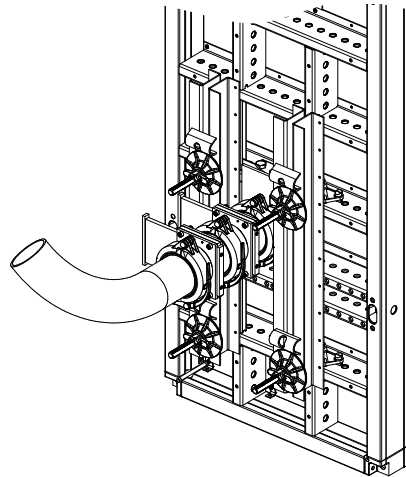

NOTE

Note!

Make sure that the shutters are open before starting to pump.

After filling the formwork close the shutters by hand.

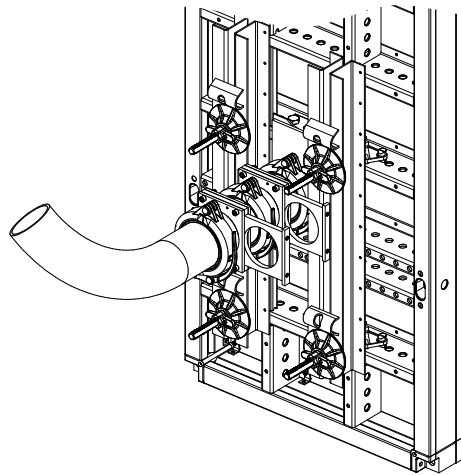

Now it is possible to open the hose clamp and remove the hose without loss of concrete.

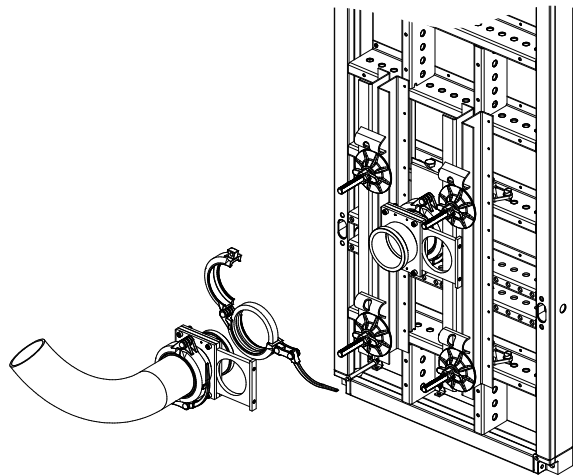

All SCC closing units DN 125 cpl. is equipped with the spindle assembly (press plate and spindle).

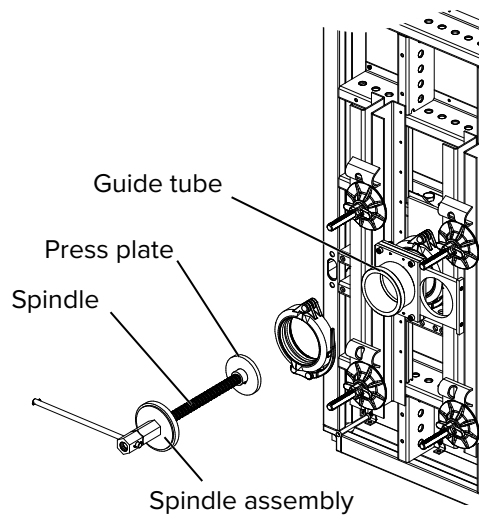

The spindle assembly is attached to the guide tube using the tube clamp and the seal ring. Now the shutter needs to be opened to allow the concrete to be pushed out of the guide tube.

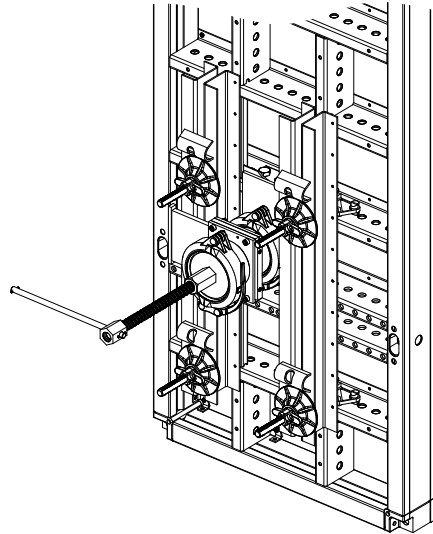

By turning the handle clockwise the press plate pushes the concrete out of the guide tube into the wall until the spindle is completely screwed to the stopend and the press plate is flush with the formwork.

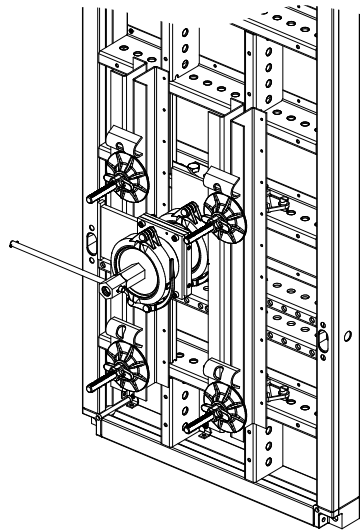

NOTE

Note!

The remaining concrete in the guide tube has to be completely pushed out as soon as possible after disconnecting the pump hose to prevent hardening of concrete in the guide tube. Otherwise, this would complicate stripping.

18 Notes on structural analysis

Unless explicitly stated otherwise, all load specifications in this document are safe working loads. This means that characteristic loads can be used for calculations. The following safety factors are included in the safe working load (where applicable):

Load:

$$\gamma_f = 1.5$$

Resistances:

Steel:

$$\gamma_m = 1.1$$

Imperfections, load assumptions and additional rules:

According to DIN EN 1993/DIN EN 12810/DIN EN 12811/DIN EN 12812/DIN EN 1991

Aluminium:

$$\gamma_m = 1.1$$

Imperfections, load assumptions and additional rules:

According to DIN EN 1999/DIN EN 12810/DIN EN 12811/DIN EN 12812/DIN EN 1991

Timber:

$$\gamma_m = 1.3;$$

$$K_{mod} = 0.9$$

Imperfections, load assumptions and additional rules:

According to DIN EN 1995/DIN EN 12810/DIN EN 12811/DIN EN 12812/DIN EN 1991

Concrete:

$$\gamma_m = 1.5$$

Imperfections, load assumptions and additional rules:

According to DIN EN 1992/DIN EN 12810/DIN EN 12811/DIN EN 12812/DIN EN 1991

Concrete steel:

$$\gamma_m = 1.15$$

Imperfections, load assumptions and additional rules:

According to DIN EN 1992/DIN EN 12810/DIN EN 12811/DIN EN 12812/DIN EN 1991

These values only include those loads that derive from the respective part itself (unless stated otherwise). An increase in the loads due to effects in the full system (e.g. Theory II, substitute horizontal loads, scaffolding class...) must be considered.

19 Chronology

Changes since edition 2020-01		
Change	Page	Date
Panel Anchor Bracket (code:605999) added.	96	2022-04-24

Hünnebeck in the UK

Rush Lane, Dosthill
 Tamworth, West Midlands, B77 1LT
 Tel.: +44 (0) 1827 289 955
 info-uk@huennebeck.com
 www.huennebeck.de

The contents of this document, including without limitation, the products, design, images, text, trademarks, service marks and logos contained herein, are protected by copyright and other intellectual property rights. No rights or licences are granted.

The contents of this document are not to be reproduced mechanically, electronically or otherwise, including for distribution, sale or display without our written permission.

The illustrations, processes, materials and/or information in this document are for general information only on the basis that conditions and procedures may differ. No representation, warranty or guarantee is made or implied, including in relation to the fitness or suitability. Overviews and diagrams are for illustrative purposes only.

Specifications may vary and BrandSafway reserves it rights to vary specifications, procedures, and materials due to continuous development, or when required to comply with new regulations, other safety guidance's or industry advancements. The processes set out in the documents should only be undertaken by qualified authorised personnel. The information contained in this document is for use for the applicable product, obtained directly from us.

We may also issue safety notes on products or packaging where required. These notices may affect the manner in which products are used and should therefore be adhered to. The most recent publication is applicable.

Performance, procedures and results may differ based on actual site conditions.

The aforementioned statements do not seek to limit our liability for fraud, or for personal injury or death caused by our negligence. However, we will not be liable for any damage to property, personal injury or any losses caused by failure to follow the instructions contained in our material. It remains the responsibility of the user to comply with the applicable regulations.

Supply of this product is subject to our terms and conditions. For more information, including on the specification, our terms and conditions/terms of business and for installation and dismantling procedures, please contact us.

© 2023 Hünnebeck GmbH. All rights reserved.

Last modified: April 2023
Keep for later use!